



I-381
MARCH 2016

KWP
Non-Clogging Process Pump

**INSTALLATION, OPERATION AND
MAINTENANCE INSTRUCTIONS**

Part Number: _____

Serial Numbers: _____

 These operating instructions contain fundamental information and precautionary notes. Please read the manual thoroughly prior to installation of unit, electrical connection and commissioning. It is imperative to comply with all other operating instructions referring to components of individual units.

 This manual shall always be kept close to the unit's location of operation or directly on the pump set.

SERVICE RECORD PAGE

Service No. _____ Model _____ Size and Type _____

Customer Order No. _____ Date Installed _____

Installation Date	Location	Application

PUMP RATING

Capacity _____ Total Head _____

Suction Pressure _____ Speed (RPM) _____

Liquid pumped _____ Temperature _____

Specific Gravity _____ Viscosity _____

Service _____

PUMP MATERIALS

Casing _____ Impeller _____ Shaft _____

Gaskets _____ Bearing Frame _____

Mechanical Seal/Packing _____

MOTOR DATA

Motor _____ Make _____ Serial No. _____

Type _____ Frame _____ AC or DC _____

HP _____ RPM _____ Volts _____

Phase _____ Cycles _____

NOTES ON INSPECTION AND REPAIRS

INSPECTION DATE	REPAIR TIME	REPAIRS	COST	REMARKS

INSTALLATION, OPERATION AND MAINTENANCE INSTRUCTIONS

TABLE OF CONTENTS

SECTION/PARAGRAPH	PAGE	SECTION/PARAGRAPH	PAGE
I. GENERAL DESCRIPTION AND SAFETY		VI. MAINTENANCE	11
PRECAUTIONS.....	1	A. Lubrication of Pump Bearings.....	12
A. General Information	1	B. Lubrication of Motor	12
B. Disclaimer	1	C. Torque Values.....	12
C. Personnel Qualification and Training	1	VII. SERVICE AND REPAIR.....	13
D. Pump Identification.....	1	A. Preparations for Disassembly of Pump	13
E. Parts Inventory Guide	2	B. Disassembly of Pump	13
F. Parts Ordering.....	2	C. Parts Inspection	14
G. Safety Precautions	2	D. Reassembly of Pump.....	15
II. INSPECTION AND STORAGE	3	E. Replacement of Wear Ring.....	16
A. Inspection.....	3	F. Motor	17
B. Storage of Pump	3	G. Coupling.....	17
III. INSTALLATION	3	H. Check Valve	17
A. Location.....	3	VIII. PARTS LISTS AND DRAWINGS	17
B. Handling	4		
C. Foundation	4	LIST OF TABLES	
D. Leveling of Unit	4	NUMBER	TITLE
E. Grouting	4	1. Permissible Forces and Moments	8
F. Coupling Alignment.....	6	2. Bearing Oil Frame Capacities	9
G. Pre-Installation Procedures.....	7	3. Pumping Unit Troubleshooting	10
H. Piping	7	4. Recommended Torque Values (ft-lbs).....	12
I. Auxiliary Piping Connection and Gauges.....	7	5. Recommended Equipment	12
J. Permissible Forces and Moments at the Pump Nozzles	7	6. Factory Wear Ring Clearance (Inches)	15
K. Motor	8	7. Recommended Spare Parts List.....	17
L. Direction of Rotation.....	8		
M. Final Alignment Check	8	LIST OF ILLUSTRATIONS	
IV. OPERATION.....	8	NUMBER	TITLE
A. Pre-Start Cautions.....	8	1. Sling Position for Moving Pump.....	4
B. Oil Lubricated Bearings.....	8	2. Sling Position for Moving Pumping Unit.....	4
C. Priming	9	3. Grouting and Foundation Bolting	5
D. Starting the Pump	9	4. Coupling Alignment.....	6
E. Operating Checks	9	5. Permissible Forces and Moments at the Pump Nozzles	7
F. Stopping the Pump.....	10	6. Constant Level Oiler	12
G. Indefinite Shutdown.....	10	7. Sectional Assembly Drawing	19
V. TROUBLESHOOTING OPERATING PROBLEMS.....	10		

I. GENERAL DESCRIPTION AND SAFETY PRECAUTIONS.



A. GENERAL INFORMATION. KWP pumps are horizontal, single-stage, single entry, non-clogging centrifugal process pumps. Carver Pump Company products are carefully engineered and manufactured and, if properly installed, maintained, and operated, should provide maintenance-free operation and a long service life.



These instructions must always be kept close to the product's operating location or directly with the product.

This manual is designed to provide sufficient material to properly maintain the total pumping unit. The information presented should improve your knowledge and understanding of the KWP, Non-Clogging Process Pump, thus upgrading the reliability, service life, and quality of pump maintenance.

These operating instructions do not take into account local regulations; the operator must ensure that such regulations are strictly observed by all, including the personnel called in for installation. Compliance with such laws relating to the proper installation and safe operation of the pumping equipment is the responsibility of the equipment owner and all necessary steps should be taken by the owner to assure compliance with such laws before operating the equipment. These instructions are intended to facilitate familiarization with the product and its permitted use to help satisfy safety requirements. Always coordinate repair activity with operations personnel, and follow all plant safety requirements and applicable safety and health laws/regulations.

Refer to Figure 7, the sectional assembly for the location of parts identified by item numbers. Variations do exist between configurations, not all parts described in the text may be on your configuration.

These instructions should be read prior to installing, operating, using and maintaining the equipment in any region worldwide and in conjunction with the main user instructions provided. The equipment must not be put into service until all the conditions relating to safety instructions have been met.

B. DISCLAIMER. Information in these User Instructions is believed to be reliable. In spite of all the efforts of Carver Pump Company to provide sound and all necessary information the content of this manual may appear insufficient and is not guaranteed by Carver Pump Company as to its completeness or accuracy.

C. PERSONNEL QUALIFICATION AND TRAINING. All personnel involved in the operation, installation, inspection and maintenance of the unit must be qualified to carry out the work involved. If the personnel in question do not already possess the necessary knowledge and skill, appropriate training and instruction must be provided. If required the operator may commission the manufacturer/supplier to provide applicable training.

Follow instructions in this manual carefully. Factory warranty applies only when pump operates under conditions as specified on order acknowledgment, and if pump is properly installed and maintained as recommended herein. A copy of this manual should be available to operating personnel. Additional copies of this manual are available upon request from Carver Pump Company and your local distributor. For comments and/or questions about information provided, please contact Carver Pump Company or your local distributor.

D. PUMP IDENTIFICATION. The type of pump, pump size, operating data, and serial number are all stamped on the nameplate attached to the pump. Pump specifications should be recorded upon receipt of the pumping unit. Record all necessary information on the pump service record page and inspection and repair record provided at the front of this manual. This information must be included in all correspondence regarding the unit. This will ensure that the correct pump and/or parts are ordered in a timely manner.

E. PARTS INVENTORY GUIDE. To avoid unnecessary delays for maintenance, spare parts should be readily available, purchase before and keep in stock, for normal service. Most conditions will be covered if this manual is followed. For every one to three pumps, stock one spare set consisting of items listed in Table 7, Recommended Spare Parts. Part numbers correspond to Figure 7.

F. PARTS ORDERING. When ordering replacement parts, please specify:

- Serial number of pump (located on nameplate)
- Part name (located on parts list)
- Quantity of parts needed

Carver Pump Company may ship an interchangeable part that is not identical in appearance or symbol. This is done only if the part has been improved. Examine parts carefully upon delivery before questioning factory or company representative. Never return parts to the factory without authorization from Carver Pump Company.

If an impeller is ordered, specify diameter across blade tips. Be sure diameter was NOT trimmed further than diameter shown on Carver Pump Company records.

If a driver or driver parts are ordered, specify name of manufacturer and all other data found on the driver nameplate.

G. SAFETY PRECAUTIONS. The manual is designed to provide adequate instructions for the safe and efficient installation, operation, or maintenance of the pump. Failure or neglect to properly install, operate, or maintain the pump may result in personal injury, property damage, or unnecessary damage to the pump. This manual must be read and understood both by the installing personnel and the responsible trained personnel/operators prior to installation and operation, and it must always be kept close to the location of the pumping unit for easy access.

G.1 Summary of Safety Marking.

The safety instructions contained in this manual whose non-observance might cause hazards to persons are specially marked with the symbol:



General hazard sign to ISO 7000 - 0434.

The word "Caution" is used to introduce safety instructions whose non-observance may lead to damage to the machine and its functions.

Instructions attached directly to the machine, e.g.

- Arrow indicating the direction of rotation
- Markings for fluid connections must always be complied with and be kept in a perfectly legible condition at all times.

Observe all note, caution or danger tags attached to the equipment or included in this manual.

G.2 Non-compliance with Safety Instructions.

Non-compliance with safety instructions may result in personal injury, property damage, or unnecessary damage to the pumping unit. Non-compliance with these safety instructions will also lead to forfeiture of any and all rights to claims for damages. Non-compliance, can for example, result in:

- Failure of important pumping unit functions.
- Failure of prescribed maintenance and servicing practices.
- Hazard to personnel by electrical, mechanical, and chemical effects as well as explosion.
- Hazard to the environment due to leakage of hazardous substances.

G.3 Safety Instructions for Maintenance, Inspection, and installation Work.

The operator is responsible for ensuring that all maintenance, inspection and installation work be performed by authorized, qualified personnel who are thoroughly familiar with the manual and pumping unit.

The pumping unit must have cooled down to ambient temperature, pump pressure must have been released and the pump must have been drained before working on any pumping unit.

Work on the pumping unit must be carried out during shutdown. The shutdown procedure described in the manual for taking the unit out of service must be adhered to.

Pumps handling fluids that are hazardous to personnel must be decontaminated prior to being worked on.

Immediately following completion of the work, all safety relevant and protective devices must be reinstalled and/or reactivated.

Please observe all instructions set out in the section on start-up before returning the pumping unit to service.

G.4 Unauthorized Modification and Manufacture of Spare Parts.

Modifications or alterations of the pumping unit supplied are only permitted after consultation with Carver Pump and to the extent permitted by Carver Pump. Original spare parts and accessories authorized by Carver Pump ensure safety. The use of other parts can invalidate any liability of Carver Pump for consequential damage and/or warranty.

G.5 Unauthorized Modes of Operation.

The warranty relating to the operating reliability and safety of the unit supplied is only valid if the pumping unit is used in accordance with its designated use as described in the following sections. The limits stated on the nameplate must not be exceeded under any circumstances.

II. INSPECTION AND STORAGE.

A. INSPECTION. Upon receipt of the shipment, unpack and inspect the pumping unit and individual parts to insure none are missing or damaged. Carefully inspect all boxes and packing material for loose parts before discarding them. Immediately report any missing parts or damage incurred during shipment to the factory and to the Transportation Company and file your "damage and/or lost in shipment" claim with the carrier.

B. STORAGE OF PUMP. If the equipment is not to be immediately installed and operated, store it in a clean, dry, well-ventilated place, free from vibrations, moisture and rapid or wide variations in temperature.

NOTE

Storage requirements vary depending on climatic environment, length of storage and equipment. For storage periods of three months or longer, contact manufacturer for specific instructions. Improper storage could damage equipment and would result in non-warranty covered restoration of non-warranty covered product failures.

When storing the pump up to three months rotate the shaft for several revolutions at least once per month to coat the bearings with lubricant, retard oxidation and corrosion, and prevent possible false brinelling.

The motor bearings should be prepared for storage according to the motor manufacturer's instructions, in

the motor manufacturer's maintenance manual, which should come with the motor.



For shipment and long term storage purposes the pump ball bearing shall be fogged once every 30 days during storage with a rust retardant compatible with the oil used in the system to prevent rusting.

Consider a unit to be in storage when:

1. It has been delivered to the job site and is waiting to be installed.
2. It has been installed but operation is delayed pending completion of construction.
3. There are long (30 days or more) periods between operating cycles.
4. The plant (or department) is shut down for periods of longer than 30 days.

Measures to be taken for prolonged shutdown of installed pumping unit. If the pumping unit remains installed a periodic check of operation is in order to make sure that the pump is always ready for instant start-up and to prevent the formation of deposits within the pump and the pump intake area. Start up the pumping unit regularly once a month or once every 3 months for a short time (approximately 5 minutes) during prolonged shutdown periods. Prior to operation check run ensure that there is sufficient liquid available for operating the pump.

III. INSTALLATION.

A. LOCATION. The pump assembly should be located in an area that will permit periodic inspection and maintenance. Head room and access should be provided and all units should be installed in a dry location with adequate drainage. The discharge piping should be direct with as few elbows and fittings as possible.

The pump assembly should be installed as close to the fluid as possible. A short, direct suction pipe can be used to keep suction losses at a minimum. If possible, locate the pump so fluid will flow by gravity to the suction opening. The discharge piping should be direct with as few elbows and fittings as possible. The total net positive suction head available (NPSHA), which includes the suction lift and pipe friction losses, must be greater than the net positive suction head required (NPSHR) by the pump.

B. HANDLING.



Use a hoist with adequate lifting capacity.
Do not pick up the complete unit by the motor or the pump shafts or motor lifting eyes.
If the pumping unit slips out of the sling arrangement, it may cause injury to personnel and/or damage to the pumping unit.

Moving the unit requires proper preparation and handling. Always make sure that the pump or the pumping unit remains in a horizontal position while being moved and cannot slip out of the transport suspension arrangement. Use a sling for pumps without baseplates, see Figure 1. To lift a horizontal mounted unit, a hoist or suitable lifting device should be attached to each corner of base structure, see Figure 2. The individual motor may be lifted using proper eyebolts provided by the manufacturer, but these should not be used to lift the assembled unit.

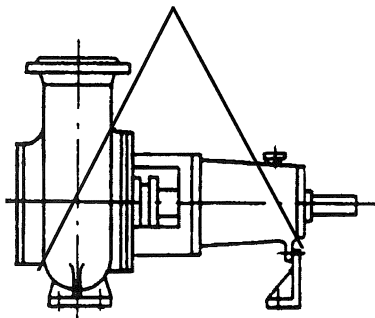

Figure 1. Sling Position for Moving Pump

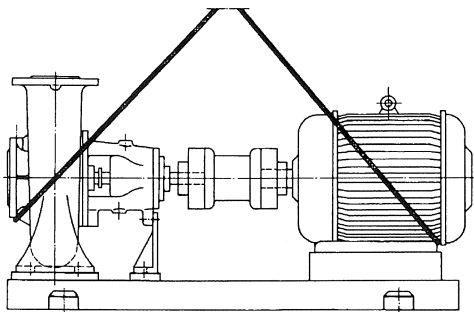

Figure 2. Sling Position for Moving Pumping Unit

C. FOUNDATION. Make sure that the concrete foundation has set firmly before placing the unit on it. Its surface must be truly horizontal and even. The foundation bolts must be inserted in the baseplate holes. The foundation should be 3 to 6 inches wider and longer than the baseplate, have a level surface, and be of sufficient mass to prevent vibration and form a permanent rigid support for the unit. The best foundations are concrete with anchor bolts of adequate size embedded in the foundation in pipe sleeves having an inside diameter 2-1/2 times larger than the bolt diameter. This will allow for accurate positioning of the unit. Keep the concrete surface clean, yet rough.

D. LEVELING OF UNIT. When the pump is supplied complete with coupling, motor, and baseplate, the unit is assembled at the factory. Lower unit onto foundation, positioning base structure so anchor bolts are aligned in middle of holes in base.

As soon as the pump and driver, mounted on a base plate, is placed on the foundation, remove the coupling guard and disconnect coupling halves. Reconnect the coupling after alignment operations have been completed per Section III, Paragraph F, Coupling Alignment. The base plate should be supported on either rectangular metal blocks with shims or on metal wedges having a small taper. The support pieces should be placed close to the foundation bolts. Refer to Figure 3, Grouting and Foundation Bolting. Place supports directly under the part of the base plate, which carries the greatest weight. Space the supports closely enough to provide uniform support of the base plate. Adjust the metal supports or wedges until the pump and driver shafts are level. Check coupling faces, as well as, suction and discharge flanges of the pump by means of a level. Make corrections, as necessary, by adjusting the supports or wedges under the base plate.

The base should be supported on metal shims or metal wedges placed directly beneath the part of the base supporting the most weight. The shims or wedges should be spaced close enough to give support and stability.

Adjust metal supports or wedges until suction and discharge flanges are level.



Do not attempt to straighten the base by using the anchor bolts.

E. GROUTING. After the pumping unit has been leveled and the alignment is correct, grout the unit to the foundation using a high-grade, non-shrinking grout. Proceed grouting using the following procedure:

Prepare concrete foundations, anchor bolts and leveling screws according to individual instructions covering these items.

1. Wax forms heavily with at least three coats of paste wax. Forms must be substantial and well braced. All corners, joints, bottoms must be sealed with silicone caulk for water tightness. All forms should have a 45° chamfer strip installed to prevent stress risers.
2. Anchor bolt-free length must be wrapped with duct seal or electricians plastic tape to prevent grout from contacting the bare metal. Grout sticking to the anchor bolt will prevent the elongation necessary to develop the clamping force. Failure to do this will result in broken anchor bolts.
3. Leveling screws must be greased to permit removal prior to the final torque.
4. Do not use shim packs as a leveling device unless it is planned to remove them prior to final torque application.

5. Leveling screw pads should be a minimum of 1/2" thick with minimum diameter of 3". Corners of pad must be rounded to approximately 1/8" radius to prevent stress cracking. Set leveling screws on the chipped concrete surface. Set the pad with quick set cement or resin repair compound. With jacking bolt pads secure and level, set and level base with leveling screws.
6. The underside of the standard factory steel base plate maybe painted with epoxy grout primer and would only require proper cleaning. If the base must be sandblasted, prepare the contact faces to SSPC-SP 6 Spec. If base cannot be set within 24 hours of blasting, the underside must be coated with a compatible rust inhibitive primer. Tighten foundation bolts loosely. **Allow the grout to fully cure before firmly tightening the foundation bolts.**

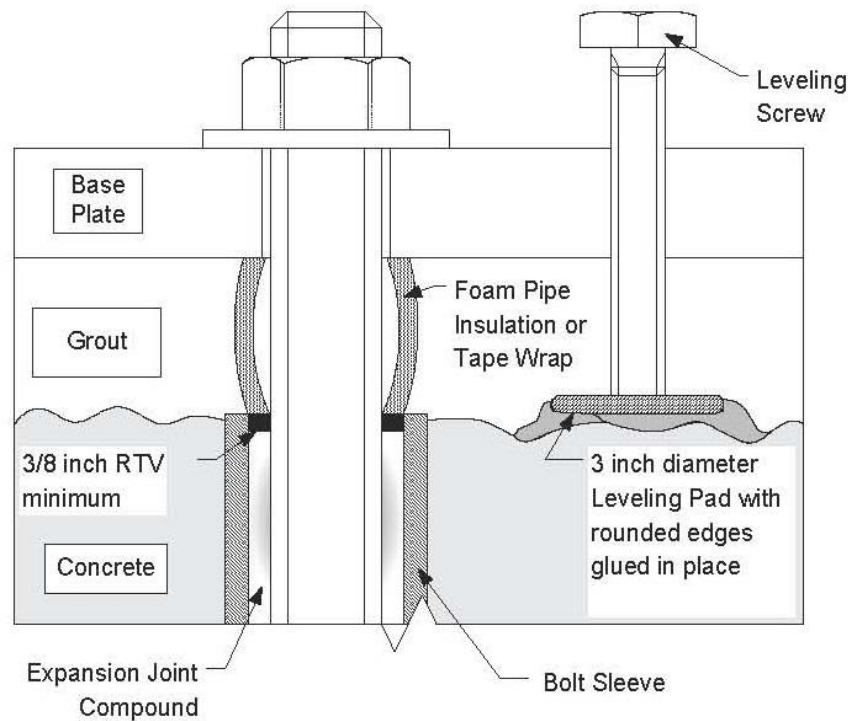

Figure 3. Grouting and Foundation Bolting

F. COUPLING ALIGNMENT. The pump and motor are connected by a coupling. Alignment is necessary when the pump or motor are removed from the base. The coupling should NOT be reconnected until the alignment has been completed. Always check the coupling alignment after shipping. The following is how to check the coupling alignment.

NOTE

Refer to coupling manufacturer's manual for instructions regarding shaft alignment and recommended installation limits.

Soft Foot – The equipment must rest flat on its base. If one or more feet of the pump or motor are shorter, longer, or angled in some way to prevent uniform contact (a condition commonly known as “soft foot”) it must now be corrected.

To improve the life of the coupling, the shafts must be aligned to minimize deflection of the flexing elements. Shaft alignment is required in the axial, parallel, and angular directions, with each of these values not to exceed the recommended installation limits. Shaft alignment can be measured using various established methods, including Laser Alignment, Reverse Dial Indicator, and Rim and Face.

The motor and pump shafts must be accurately aligned as any misalignment can cause damage to the coupling, motor, or pump. When the shafts are in correct alignment, the coupling hubs will be on a common axis, concentric with each other, and at the correct distance apart. If the coupling hubs are misaligned, it is general practice to adjust the driver to the pump. Insert full

shims under the feet or supports of the motor and tighten fastening bolts until correct alignment is achieved.

1. Move the pump or motor to achieve acceptable alignment. When properly aligned, the disc packs will be centered and approximately parallel to their mating flange faces and the flexing elements will have little visible waviness when viewed from the side.

NOTE

Refer to the coupling manufacturer's manual for recommended installation limits for Parallel, Angular, and Axial alignment.

2. The “Parallel Misalignment” value (P) is the offset between the centers of the hubs, as shown in Figure 4.
3. When the Parallel Offset is measured by rotating the hubs in unison with dial indicators as shown in Figure 4, the Total Indicator Reading (TIR) should be divided by (2) to calculate (P).
4. It should be noted that parallel offset measured on the hub surfaces includes misalignment of the equipment shafting plus any variation (TIR) in the hubs. This may be helpful to consider during problem solving for alignment difficulties.
5. The “Angular Misalignment” value is the maximum difference between the measurements X and Y taken at opposite ends of the hub flanges, as shown in Figure 4.

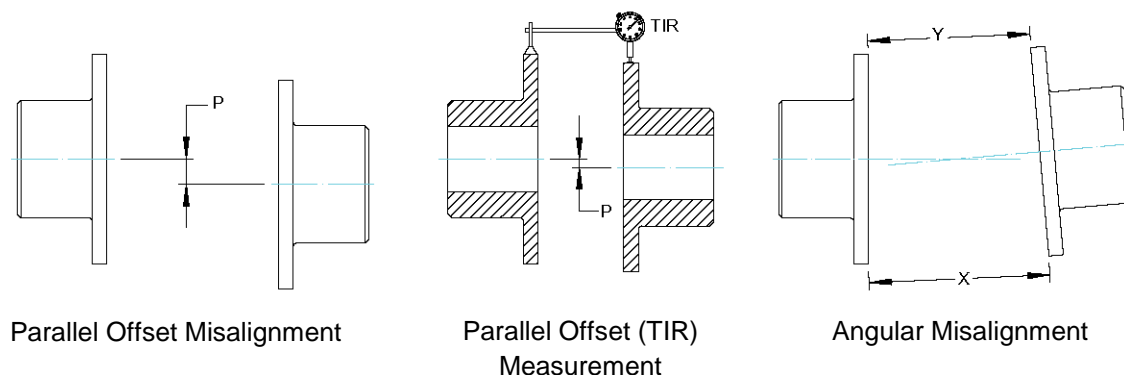

Figure 4. Coupling Alignment

G. PRE-INSTALLATION PROCEDURES.

1. Check the pump foundation and confirm the bolting surface is flat and the bolt pattern is correct.
2. Slowly lower pump onto the foundation.
3. Rotate the pump by hand utilizing the coupling. Check for any mechanical hesitation, binding or any acoustically transmitted signals from the pump. Hand rotation should be smooth and silent. Install the pump to foundation bolting and tighten to the system torque values. The pump should be rotated frequently during the procedure to tighten down the pumping unit.
4. After the pumping unit has been completely tightened down to the foundation, confirm that there is no binding.
5. Connect the piping.

H. PIPING. All piping should be independently supported near the pump so that pipe strain will not be transmitted to the pumping unit.



All piping connections must be made with the pipe in a freely supported state. Do not apply vertical or side pressure to align the piping with the pump flange.

Before connecting suction, discharge, and auxiliary piping, check to see that the piping is absolutely clean internally. Any debris in the piping will be drawn into the pump passageways and can cause extreme damage. The internal diameters of the suction and discharge lines must be equal to the internal diameters of the pump suction and discharge nozzles.

Suction lift lines shall be laid with a rising slope toward the pump and suction head lines with a downward slope towards the pump.

The suction pipe must be air tight and sloped upward to pump flange to avoid air pockets which will impair pump operation. The discharge pipe should be as direct as possible using a minimum number of valves to reduce pipe friction losses.

Never use a straight taper (concentric) reducer in a horizontal suction line because air pockets may form in the top of the reducer and the pipe. Use an offset (eccentric) reducer instead.

It is recommended to install a check valve and closing valve in discharge line and closing valve in suction line, depending on the type of plant and pump. The check valve, between the pump and valve, protects pump from water hammer and prevents reverse rotation in the event of power failure. Closing valves are used in priming, starting, and pump shut down. Pump must never be throttled by use of a valve in the suction line.

Thermal expansions of the pipeline must be compensated by appropriate measures so as not to impose any extra loads on the pump exceeding the permissible pipeline forces and moments. Refer to Table 1 for permissible forces and moments.

I. AUXILIARY PIPING CONNECTIONS AND GAUGES. In addition to primary piping connections, the pump may require other connections such as gauges or drains. All these lines and gauges should now be installed.

J. PERMISSIBLE FORCES AND MOMENTS AT THE PUMP NOZZLES. The forces and moments in Table 1 are to be understood as the limit for a single acting force or moment along the particular coordinate axes or any resultant of two or more forces and moment.

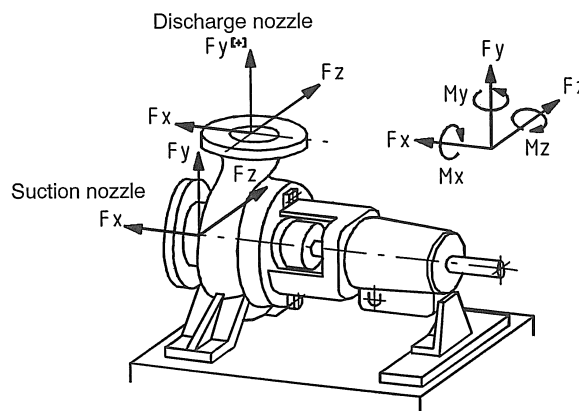

Figure 5. Permissible Forces and Moments at the Pump Nozzles.

Table 1. Permissible Forces and Moments

Pump Size	ANSI Flange Size (Inches)		Forces									Moments					
			Suction Nozzle				Discharge Nozzle					Suction Nozzle			Discharge Nozzle		
	Suct	Disch	Pounds				Pounds					Foot-Pounds			Foot-Pounds		
			Fx	Fy	Fz	Fres	Fx	Fyt*	Fyc**	Fz	Fres	Mx	My	Mz	Mx	My	Mz
65-200	3	2.5	2150	1400	1700	2200	1400	900	1750	1150	1800	1450	1100	750	1150	850	600
80-200 80-250	4	3	2700	1750	2150	2750	1700	1100	2150	1400	2200	2000	1500	1000	1450	1100	750
100-250	5	4	3700	2400	2950	3800	2150	1350	2700	1750	2800	2750	2100	1400	2000	1500	1000

*Tension

**Compression

K. MOTOR. See motor vendor's manual for motor information and information on connecting to the power supply.



Connection to the power supply must be effected by a trained electrician only. Check available main voltage against the data on the motor rating plate and select appropriate start-up method.

L. DIRECTION OF ROTATION. Correct pump rotation is indicated by an arrow on the frame adaptor. The standard direction of rotation, viewed from the motor end, is clockwise.

M. FINAL ALIGNMENT CHECK. Re-check the alignment as described in Section III, Paragraph F Coupling Alignment and verify the correct distance between the coupling and the coupling guard. It must be easy to rotate the shaft by hand at the coupling.

IV. OPERATION.

A. PRE-START CAUTIONS.



Before activating the pumping unit, check to make sure there are no personnel working on the unit. Serious injury or death to personnel could result if the unit is activated while being worked on.

1. Before starting or operating the pump, read this entire manual, especially the following instructions.
2. Observe all caution or danger tags attached to the equipment.

3. Fill bearing frame with oil. Pumps are shipped with no oil in the bearing frame.



Never run the pump dry. Close running fits within the pump are liquid lubricated. Dry running will result in pump seizure or damage.

4. Before starting the pump, fill the volute and suction line with liquid. The pump may be primed by using an ejector or vacuum pump.
5. Before starting a mechanical seal pump equipped with external flush lines, turn on seal water, and confirm the seal water is of sufficient pressure.
6. Check final alignment of pump and driver. Both shafts must turn freely by hand.
7. If excessive vibration or noise occurs during operation, shut the pump down and rotate shaft by hand. If excessive vibration or noise continues, consult a Carver representative.
8. Before starting the pump, install closed guards around all exposed rotating parts.

B. OIL LUBRICATED BEARINGS. The bearing housing has to be filled with lubricating oil before operation. Hinge down the bottle of the constant level oiler and pour oil into the opening of the bottle stem. Replace the bottle and allow oil to flow into the bearing reservoir. It may require the filling of the bottle several times before the oil level in the reservoir is equal for which the oiler is adjusted. The bottle must not be allowed to become empty during operation.

If the vent plug on top of the bearing frame is accessible, the reservoir may also be filled through this aperture. Remove the vent plug, hinge the bottle of the constant level oiler down, and pour oil into the vent plug opening until it reaches the level of the connection

elbow of the oiler. Fill the oiler bottle and snap it back into position. Reinstall the vent plug. The bearing frame reservoir oil fill capacities are listed in Table 2.

Table 2. Bearing Oil Frame Capacities

Pump Size	Bearing Frame Size	Oil Fill Capacity (Fl. Oz. @ 70° F)
65-200 80-200	45	13.5 (400 ml)
80-250 100-250	55	17 (503 ml)

C. PRIMING. Dry running a centrifugal pump can result in extensive damage and possible seizing. It is, therefore, imperative that the pump be primed prior to initial start-up and that prime must be maintained through subsequent start-stop cycles.

The priming procedure is different for positive and negative suction head systems. Follow the procedure listed below.

Positive Suction Head:

1. Open the vent on the highest point on the pump volute.
2. Open all suction valves.
3. Allow liquid to flow from vent hole until all air bubbles are vented. Then close the vent.
4. The pump is now primed.

Negative Suction Head:

1. Install an ejector or vacuum pump on the vent at the highest point on the volute.
2. Close the discharge valve.
3. Open the suction valve.
4. Start the ejector or vacuum pump.
5. Allow liquid to flow until a continuous flow is exhausted from ejector. Then close the valve to the vent.
6. The pump is now primed.

D. STARTING THE PUMP.



Do NOT operate pumping unit against a closed discharge system. If pump has any chance of seeing operation against a closed system, a bypass system allowing a minimum design flow should be installed. This bypass will be satisfactory for short periods of operation. For extended periods of operation the bypass should be sized for the minimum continuous flow required by the pump.

1. Check pump for proper priming and lubrication.
2. Fully open the suction valve.
3. Open discharge valves slightly, about 1 to 1 ½ turns if pump is being started for the first time or from being turned off for overhaul. Start the pump.
4. Slowly open discharge valves and adjust pressure and flow to the appropriate operating conditions. Refer to pump nameplate and system operating procedures for design point condition.

E. OPERATING CHECKS.

1. Check for undue vibration or noise. If any occurs and does not stop within a short period of time, turn off the pump. For determination of the cause and its remedy refer to troubleshooting in Section V or consult Carver Pump Company.
2. Check and record flow and pressure readings. The flow and pressure readings should be within the operating system guidelines and similar to number stamped on the pump nameplate.
3. Check and record bearing temperature. It should not exceed 180 degrees F.
4. Check the oil level in the bearing housing daily. Confirm that oil level is at center of bullseye. If equipped with a constant level oiler, check oil level and refill as required.
5. Check and record power input to the motor.
6. Check for leakage at mechanical seals.

F. STOPPING THE PUMP.

1. If the pump is being stopped for overhaul, slowly close the discharge valve. Otherwise leave discharge valves set at condition.
2. Stop the pumping unit in accordance with the directions on the electrical power supply.
3. Tagout and lockout power to motor according to OSHA Standard 1910.147.
4. Close suction valve and any auxiliary fluid lines.
5. The pumping unit is now off.

G. INDEFINITE SHUTDOWN. Relubricate bearings. Provide pump assembly with a protective cover. Remove casing plug to drain casing. Drain all piping if there is a possibility of liquid freezing.

V. TROUBLESHOOTING OPERATING PROBLEMS.

If you have followed the installation and starting procedures outlined in this manual, the pump should provide reliable service and long life. However, if operating problems do occur; significant time and expense can be saved if you refer to Table 3 to eliminate the most common causes of those problems.

Table 3. Pumping Unit Troubleshooting

SYMPTOM	PROBABLE CAUSE	CORRECTIVE ACTION
Failure to deliver liquid.	<ol style="list-style-type: none"> 1. Discharge head above shutoff. 2. Check valve stuck or improperly installed. 3. Impeller or suction clogged. 	<ol style="list-style-type: none"> 1. Check pump rating against actual head condition. 2. Adjust and/or reverse valve. 3. Inspect suction and impeller. Clean as necessary.
Excessive power consumption.	<ol style="list-style-type: none"> 1. Head lower than rating: trying to pump too much liquid or operating at end of performance curve. 2. Specific gravity or viscosity of oil is too high 3. Mechanical defects such as binding rotating elements. 4. System head lower than design condition. 5. Incorrect impeller diameter. 	<ol style="list-style-type: none"> 1. Adjust pressure flow. 2. Check oil temperature and adjust as necessary. 3. Check for excessive pipe strain. Check foundation bolting. Replace defective parts. 4. Adjust system head. Trim impellers to actual condition. 5. Replace impeller or trim impeller to correct diameter. Consult with Carver Pump before trimming impellers.
Insufficient discharge or flow.	<ol style="list-style-type: none"> 1. Discharge head above shutoff. 2. Air or gases in oil. 3. Impeller or suction partially clogged. 4. Wrong direction of rotation. 5. Specific gravity or viscosity of oil is too high. 6. Incorrect impeller diameter. 	<ol style="list-style-type: none"> 1. Check pump rating against actual head condition. 2. Adjust and/or redesign suction system. Add oil to system. 3. Inspect strainer and impeller and clean as necessary. 4. Reverse direction of rotation. 5. Check oil temperature and adjust as necessary. 6. Replace impeller or trim impeller to correct diameter. Consult with Carver Pump before trimming impeller.

Table 3. Pumping Unit Troubleshooting (Continued)

SYMPTOM	PROBABLE CAUSE	CORRECTIVE ACTION
Vibration excessive.	<ol style="list-style-type: none"> 1. Foundation bolting loose. 2. Coupling halves not properly oriented relative to each other. 3. Impeller partially blocked. 4. Wrong rotation. 5. Insufficient foundation. 6. Pipe strain. 7. Coupling key to motor or coupling key to pump is not correct length. 8. Motor improperly balanced. 	<ol style="list-style-type: none"> 1. Torque bolting to proper values. 2. Adjust coupling halves system relative to match marks. 3. Inspect impeller and clean as necessary. 4. Adjust direction of rotation. 5. Stiffen foundation as necessary. 6. Modify piping as necessary. 7. Replace with key of correct length. 8. Balance motor.
Oil leak.	<ol style="list-style-type: none"> 1. Loose tube connection. 2. Defective oil seal. 3. Loose or defective gasket. 	<ol style="list-style-type: none"> 1. Tighten tube connectors. 2. Replace oil seal. 3. Tighten bolting and/or replace gasket.
Bearing temperature excessive.	<ol style="list-style-type: none"> 1. Lubrication, insufficient lubrication. 2. Defective bearing. 	<ol style="list-style-type: none"> 1. Lubricate according to Section VI, Paragraph A. 2. Replace bearing.

VI. MAINTENANCE.

Generally the pump does not need continuous supervision. The pump should always run quietly and smoothly, without vibration. To ensure such operation, the following maintenance schedule should be applied at regular intervals during operation of the pump. Occasional visual checks are recommended. Data should be recorded periodically for each pump to keep track of maintenance which has been performed and to note operational problems. A sample maintenance record sheet is provided for this purpose at the front of this manual.

Daily Inspection:

- Visually inspect unit.
- Check bearing temperatures.
- Check for leakage at mechanical seals.
- Check that oil level is at center of bullseye, if applicable. If equipped with a constant level oiler, check oil level in the constant level oiler and refill as required. Insure proper oil mist if applicable.

Weekly Inspection:

- Check power (amps) readings.
- Check pump discharge pressure. Prescribed operating discharge pressure should never drop below 90 percent of design point pressure.

- Check vibration on pump and driver bearings. Vibration should NOT exceed 1.5 of overall displacement (unfiltered) peak to peak mils (0.001") at 3600 RPM and 3.0 of overall displacement (unfiltered) peak to peak mils (0.001") at 1750 RPM.

Monthly Inspection:

- Check coupling alignment.
- If necessary, grease coupling, but Do NOT over grease.
- Check foundation bolts.

Semi-annual Inspection:

- Grease bearings or change oil. Do NOT over grease or add excess oil.
- Check coupling alignment due to settling of foundation.
- If stand-by pumps are installed, it is advisable to operate pumps on a rotational system to give each pump a periodic duty. This ensures that stand-by pumps will have periodic operation and always be in good condition for instant start-up.

300 Hours

- The first oil change should be carried out after 300 hours of operation.

3000 Hours

- After the first oil change at 300 hours subsequent oil changes should be effected at intervals of 3000 hours of operation

25000 Hours - Overhaul

- For pump overhaul, disassemble pump, complete parts inspection, and reassemble pump according to Section VII.
- Replace roller bearings.
- Inspect volute for corrosion, erosion or other damage. 3mm limit of metal loss in volute and backcover (Items 1 and 11).

A. LUBRICATION OF PUMP BEARINGS.

Ball Bearings (16 and 18). The radial bearing (16) and the thrust bearings (18) are lubricated by oil in the bearing frame.

To change oil, unscrew frame drain plug (424) in bearing housing (19) and drain oil. Flush bearing housing with petrol or benzol. Slowly rotate the shaft by hand during flushing. Replace frame drain plug and fill the bearing housing with SAE #20 (oil to be free of acid and resin). Fill bearing housing until oil can be seen in the constant level oiler. Fill reservoir with oil, place thumb over spout, invert and screw reservoir into upper casting. Allow reservoir to empty, filling the bearing housing (Figure 6). Several fillings of the reservoir may be required before the actual oil level is reached. Never use lower casting only as a fill spout, always fill thru reservoir. When oil level is reached, no more oil will run out of the reservoir bottle. When oil level is reached tighten the three setscrews on the side of the upper oiler. The constant level oiler (125) should be topped up as required during operation.

NOTE

Viewed from pump suction end.

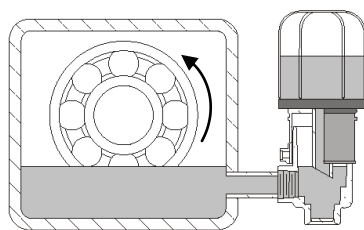

Figure 6. Constant Level Oiler

B. LUBRICATION OF MOTOR.

See motor manufacturer's instructions to be sure motor bearings are properly lubricated.

C. TORQUE VALUES.

Refer to Table 4, Recommended Torque Values. Clean and properly lubricate threads and bearing face of the fastener to obtain the proper fastener loading from these torque values. Fasteners should be tightened evenly and in stages. Refer to your torque wrench manual for the proper use of your wrench.

Table 4. Recommended Torque Values (ft-lbs)

Bolt Size	Material		
	Composite	Steel (or otherwise noted)	316 Stainless Steel
1/4"-20	5	5	7
5/16"-18	11	11	12
3/8"-16	18	18	21
1/2"-13	33	39	45
5/8"-11	54	83	97
3/4"-10	80	105	132
7/8"-9	109	160	203
1"-8	144	236	300

Table 5. Recommended Equipment

Tools	Materials	Test Equipment
Spanner Wrench Rawhide or Wood Mallet Wooden Wedge Allen Wrench Set Socket, Open, & Box Wrench Set Vice Grips Torque Wrench Bearing Heater	Oil O-ring Lubricant	Coupling Alignment Gauges Volt-Amp Meter

VII. SERVICE AND REPAIR.

Refer to Figure 7 to locate the pump parts by item number and parts list.

A. PREPARATIONS FOR DISASSEMBLY OF PUMP.

During disassembly, match mark parts so they can be replaced in their original position. All parts should be thoroughly cleaned or replaced with new, if necessary. Sealing faces should be perfectly clean. Carver Pump Company recommends that all O-rings and shims are only used once.



CAUTION

Factory authorized parts must be used to safely maintain your Carver Pump.

NOTE

To avoid damage to O-rings, check to make sure all parts are free of sharp edges or burrs.

Close suction and/or discharge valves. The pump volute should be cooled down to ambient temperature. The volute must be empty and not under pressure.

After prolonged operation, components may not be easily removed from shaft. In such instances, rust solvent may be used and suitable extracting tools applied wherever possible. Do NOT use force under any circumstances. Refer to Table 5, Recommended Equipment, for proper tooling during disassembly and assembly. Refer to appropriate sectional drawing for location of parts followed by an item number. Assemble the pump in accordance with accepted rules of engineering practice. Coat individual components with a suitable lubricant before assembling. Assembly of unit should be performed on a clean, flat surface.

While assembling the pumping unit, Carver Pump Company recommends that the following parts be replaced with new:

- O-rings / gaskets
- Shims
- Bearings
- Grease seals
- Mechanical seals

Prepare the pumping unit for disassembly using the following list:

1. Read this entire section and study the sectional view drawing, Figure 7, before disassembling the pump.



CAUTION

Before attempting to disassemble the pump, the electrical power supply to the driver must be locked and tagged in the "OFF" position to prevent injury or death to personnel servicing the pumping unit.

2. Stop the pumping unit; refer to Section IV, Paragraph F.



CAUTION

Properly decontaminate pump and piping before disconnecting the pumping unit. Applicable hazardous material procedures must be followed.

3. Slowly close discharge valves.
4. Shut off and close all valves controlling flow of liquid to and from pump. Disconnect piping and gauge line as necessary.
5. Drain volute by removing volute drain plug (422). If necessary, flush pump to remove corrosive or toxic pumpage. Reinstall volute drain plug in volute when fluid is completely drained.
6. Drain oil from bearing housing (19). If a constant level oiler (125) provides lubrication for bearings, drain oil from the bearing frame by removing frame drain plug (424) at bottom of bearing frame.
7. Remove coupling guard.
8. Disconnect coupling between pump and motor. If non-spacer coupling is fitted, the driver will have to be removed from the baseplate.

B. DISASSEMBLY OF PUMP. The instructions that follow are an aid for properly trained personnel to service your Carver Pump. These instructions refer to Figure 7. If a specific sectional assembly drawing exists for a particular job then that drawing should be referred to for service work. Read this entire section and study Figure 7 before disassembling the pump.

The back pull-out design of the KWP pump enables the pump to be disassembled without disconnecting the piping or removing the pump casing from the baseplate.

When the pump is fitted with optional spacer coupling, the driver can also remain bolted on the baseplate.

After completion of dismantling, all parts should be thoroughly cleaned or replaced by new ones if necessary. All gaskets and sealing faces should be perfectly clean. When cutting new gaskets, make sure they are exactly the same thickness as the old ones.



Use a hoist with adequate lifting capacity.

NOTE

Mark or number each component while dismantling according to sequence.

B.1 Disassembly of Pump with Packing Rings.

For pumps with packing rings use the following disassembly procedures:

1. Complete Section VII, Paragraph A before continuing with disassembly.
2. Remove volute hex nuts (617) from volute studs (633). Remove frame foot capscrew (604) holding the frame foot (53) to the baseplate.
3. Loop a rope tightly around the top stay of the frame adaptor (71) or lifting eye (730) to sustain the weight of the subassembly that is to be lifted out. Force off the frame adaptor (71), including the bolted-on bearing housing (19) and pump rotor, by means of adaptor forcing bolts (606) in the frame adaptor (71).
4. Carefully pull the complete rotor out of the volute (1) and remove it to a work area.
5. Remove frame drain plug (424) and drain the oil from the bearing housing (19).
6. Remove impeller capscrew (26) and impeller capscrew O-ring (89A). Remove impeller washer (649) and impeller nut gasket (38). Pull off impeller (2) with the aid of a puller device. Remove impeller key (32). Impeller gasket (30) will come off with impeller (2).
7. Refer to packing detail on Figure 7. Remove gland hex nuts (615) from gland studs (631). Remove packing gland (17A). Remove lantern ring (29), two packing rings (13), lantern ring (29), and two remaining packing rings (13).
8. Refer to packing detail on Figure 7. Remove backcover (11A) from frame adaptor (71). Remove throttle bushing (63).
9. Refer to packing detail on Figure 7. Remove shaft sleeve (14A) and slinger (40).
10. Remove adaptor/bearing frame hex nuts (616) from adaptor/bearing frame studs (632). Remove frame adaptor (71).
11. Remove coupling hub on pump end with the aid of a puller device. Remove coupling key (32A).
12. Remove bearing cap capscrews (607) on both ends of bearing housing (19). Remove outboard and inboard bearing caps (35 and 43) with inboard and outboard oil seals (47 and 49) and inboard and outboard bearing cap gaskets (73A and 73B).
13. Carefully drive out the shaft (6), together with radial bearing (16) and thrust bearings (18), toward the motor end.
14. If the bearings (16 and 18) need to be replaced, they should be warmed with a welding torch or a blowlamp before pulling them off the shaft (6), and the shaft (6) itself should be kept as cool as possible. Before pulling the thrust bearing (18) off, uncrimp bearing lockwasher (69) and remove bearing locknut (22). Remove bearing lockwasher (69).

B.2 Disassembly of Pump with Mechanical Seal.

For pumps with mechanical seal, use the following disassembly procedures:

1. Disassemble pump according to steps 1 through 6 as outlined above in Paragraph B.1.
2. Remove seal gland hex nuts (615) from gland studs (630). Back seal gland (17) towards bearing housing (19). Gland gasket (73F) should move with seal gland (17).
3. Remove backcover (11) from shaft (6).
4. Remove shaft sleeve (14). Remove mechanical seal (90) rotating element from shaft sleeve (14).
5. Remove seal gland (17). Remove mechanical seal (90) stationary element from seal gland (17).
6. Remove slinger (40).
7. Disassemble pump further according to steps 10 through 14 as outlined above.

C. PARTS INSPECTION.

1. All parts should be thoroughly cleaned or replaced with new ones if necessary. All gasket faces should be perfectly clean. It is

recommended that all gaskets, O-rings, and locking devices with a nylock feature be replaced with new if disturbed from position.

2. Discard and replace used oil seals and O-rings. Thoroughly wash and clean all parts with a suitable solvent.
3. Check shaft for runout, scratches, grooves, or any possible damage. Touch up scratches and grooves with a polishing cloth and inspect for remaining grooves or deep scratches. A bent or excessively damaged shaft should be replaced.
4. Inspect volute for pitting, scoring, and erosion. The inside of the volute should be free of any pits or grooves. Replace the volute if any of these defects are present.
5. Inspect mechanical seals. Sealing faces must be glossy and free of scratches, cracks or pits. Repair or replace mechanical seals that are extremely worn or damaged.
6. Inspect impeller and coupling keys for distortion and push fit into keyways. The keys should be square on all four edges. They should fit without having to be forced. The keys should not rock in keyway. Replace keys or shaft if necessary.
7. Inspect tubing for kinking. Replace kinked tubing.
8. If the impeller (2) shows excessive wear due to erosion or pitting, so that performance cannot be restored, it must be replaced. If a new impeller is installed, check to make sure that it is balanced and of the correct trim.
9. Check the wear ring clearance as follows:
 - a. Measure outside diameter of impeller (2) suction in three places.
 - b. Measure inside diameter of wear ring (7) in three places.
 - c. If difference between the high reading of the inside diameter of the wear ring (7) and the low reading of the outside diameter of the impeller (2) suction exceeds double the maximum factory installed clearances or exceeds replacement diametric clearance given in Table 6, replace the wear ring according to Section VII, Paragraph E.
10. Inspect ball bearings (16 and 18) for damage. A damaged bearing must be replaced. If bearing is removed from shaft, it is recommended that the bearing be replaced. If bearing replacement is not possible and bearing is in good condition bearing should be cleaned and protected until ready to use.

Table 6. Factory Wear Ring Clearance (Inches)

Model	Installed (CI) Diametric Range	Installed (Alloy) Diametric Range	Recommended Diametric Replacement
65-200	0.019 to 0.025	0.023 to 0.031	0.050
80-200	0.019 to 0.025	0.023 to 0.031	0.050
80-250	0.019 to 0.025	0.023 to 0.031	0.050
100-250	0.017 to 0.021	0.025 to 0.029	0.050

D. REASSEMBLY OF PUMP.

During reassembly, install parts as applicable.



CAUTION

During reassembly, install new locknuts, as they have a self-locking feature. Locknuts with a self-locking feature may not provide adequate security once disturbed from position.

During reassembly, install new O-rings, oil seals, and gaskets if disturbed from position. O-rings, oil seals and gaskets may have been damaged during disassembly.

During reassembly, Carver recommends that ball bearings (16 and 18) be replaced if disturbed from position.

NOTE

All parts should be thoroughly cleaned or replaced with new ones if necessary. All sealing faces should be perfectly clean.

D.1 Reassembly of Pump with Packing Rings.

For pumps with packing rings use the following disassembly procedures:

1. If removed, install ball bearings (16 or 18) on shaft (6) by heating ball bearings (16 or 18) in an oven at 250 degrees F. This will expand the inner race, allowing it to slip over the shaft (6).
2. Confirm that the bearing spacer (78) is still installed in the bearing frame (19). Carefully insert shaft (6) and bearings (16 and 18) into bearing housing (19).
3. Install bearing lockwasher (69) and bearing locknut (22) on shaft (6). Crimp tangs of bearing

- lockwasher (69) in grooves of bearing locknut (22).
4. Install inboard and outboard oil seals (47 and 49) in the inboard and outboard bearing caps (35 and 43). Install inboard and outboard bearing caps (35 and 43) and secure with bearing cap capscrews (607).
 5. Install coupling key (32A). Install coupling hub.
 6. Install slinger (40).
 7. Install impeller key (32). Install impeller (2), impeller nut gasket (38), impeller washer (649), and impeller capscrew (26).
 8. Install volute gasket (73) on backcover (11). Install backcover (11) in volute (1).
 9. Install frame adaptor (71) and secure with volute hex nuts (617) on volute studs (633).
 10. Install two packing rings (31), lantern ring (21), two remaining packing rings (31) and lantern ring (21). Install gland (18) and secure finger-tight with hex nuts (38) on studs (35).
 11. Install frame drain plug (424) and fill bearing housing (19) with oil as described in Section VI, Paragraph A.
 12. Carefully install complete rotor in volute (1).
 13. Secure frame foot (53) to baseplate with frame foot capscrew (604).
 14. Connect auxiliary piping.
 15. Connect, align, and lubricate coupling.
 16. Install coupling guard.
 17. Remove all tags from valves and switches. Open system valves. Reconnect power supply to motor.
 18. Start pumping unit in accordance with Section IV, Paragraphs A, B, C, and D.

D.2 Reassembly of Pump with Mechanical Seal.

For pumps with a mechanical seal use the following disassembly procedures:

1. Reassemble pump according to Section VII, Paragraph D.1, steps 1 through 8.
2. Install mechanical seal (90) stationary element in seal gland (17). Install seal gland (17) on shaft (6).
3. Install mechanical seal (90) rotating element on shaft sleeve (14). Install shaft sleeve (14).
4. Secure seal gland (17) to backcover (11) with gland hex nuts (615) on gland studs (630).

5. Reassemble the pump further according to Section VII, Paragraph D.1, steps 11 through 18.

E. REPLACEMENT OF WEAR RING.

The KWP pump has a replaceable wear ring (7) inserted into the volute (1). The clearance between the wear ring and impeller suction will increase with wear. Internal leakage will result and pump performance will decrease. The allowable clearance and method of measurement is described in Section VII, Paragraph C.

The volute (1) must be removed from the base to replace the wear ring (7). To replace the wear ring (7) follow these steps:

1. Complete Section VII, Paragraph A before continuing with disassembly.
2. Disconnect suction and discharge piping. Unbolt volute (1) from base and from adaptor (71) by removing nuts (615) and lockwashers (656) from studs (630). Set volute aside. Remove impeller capscrew (24) and impeller washer (28). The best tool to remove impeller capscrew (24) is a hex wrench welded to a socket head. Remove impeller (2) and take volute (1) and impeller (2) to work area with access to machine shop equipment.
3. Remove setscrews (677) from wear ring (7). Remove the wear ring (7) from the volute (1). This can be best accomplished on a lathe. Take this work to a machine shop.
4. Inspect the impeller (2) suction for damage.
5. Press the new wear ring (7) into the volute (1). The beveled edge of the wear ring is installed towards the impeller (2).
6. Drill and tap two holes 180 degrees apart along the edge of the wear ring (7). Secure new wear ring (7) to volute (1) by inserting setscrews (677) into these holes.
7. Place impeller (2) on an arbor and mount between centers in a lathe or a grinder. Indicate back of impeller hub to within 0.002 inch Total Indicator Runout (TIR) maximum to be sure the arbor and impeller is running square.
8. Turn the wear ring surface of impeller (2) until a 63 RMS or better finish is obtained.
9. Measure the outside diameter of the impeller (2) suction and record this value.
10. Mount the volute (1) with new wear ring (7) installed in a lathe. Indicate gasket (73) area bore to within 0.002 TIR maximum.

11. Bore wear ring (7) to within the specified tolerance listed in Table 6 over the recorded size of the outside diameter of the impeller suction.
12. If replacing wear ring during parts inspection in accordance with Section VII, Paragraph C, reinstall volute (1) to base. Proceed to Section VII, Paragraph D for reassembly.
13. Install impeller (2) and impeller washer (28) on shaft and secure the impeller capscrew (24).
14. Reinstall volute (1) on base and secure with fastener. Reconnect suction and discharge piping.

F. MOTOR. The motor should be maintained in accordance with the manufacturer's instructions.

G. COUPLING. The coupling should be maintained in accordance with the coupling manufacturer's instructions.

H. CHECK VALVE. If applicable, the check valve should be maintained in accordance with the valve manufacturer's instructions.

VIII. PARTS LISTS AND DRAWINGS.

This section contains listings of parts and corresponding drawings. Table 7 notes the recommended spare parts for this pumping unit. Figure 7 is the sectional assembly drawing with parts list.

Table 7. Recommended Spare Parts List

Item	Description	Item	Description
2	Impeller	32A	Coupling Key
6	Shaft	38	Impeller Nut Gasket
7	Wear Ring	47	Inboard Oil Seal
13	Packing Ring (For pumps with packing)	49	Outboard Oil Seal
16	Radial Bearing	73	Volute Gasket
18	Thrust Bearing	73A	Inboard Bearing Cap Gasket
22	Bearing Locknut	73B	Outboard Bearing Cap Gasket
26	Impeller Capscrew	73F	Gland Gasket
29	Lantern Ring (For pumps with packing)	89A	O-ring – Impeller Capscrew
30	Impeller Gasket	90	Mechanical Seal (For pumps with mechanical seal)
32	Impeller Key	649	Impeller Washer

This page left intentionally blank.

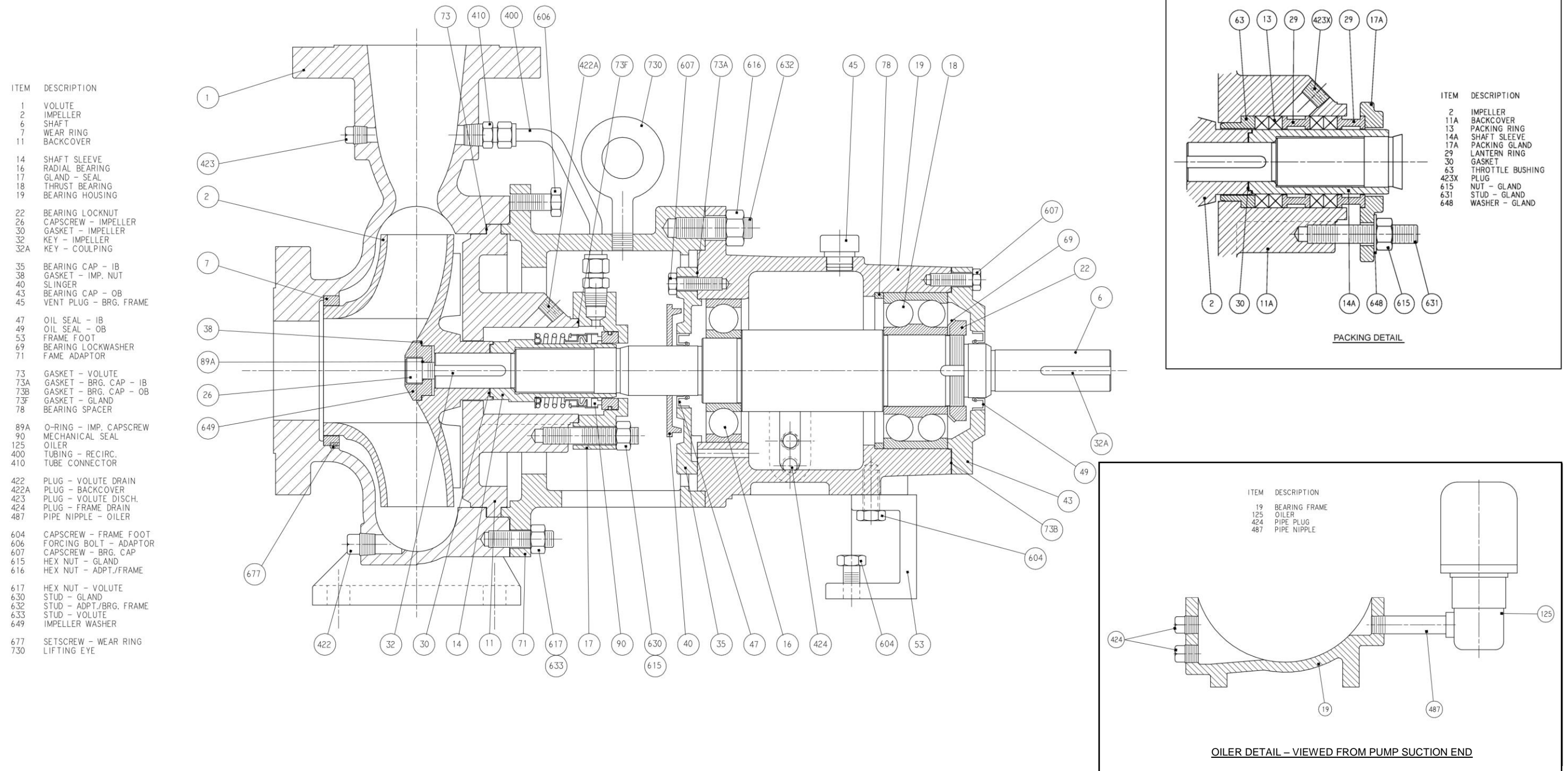

PUMP WITH MECHANICAL SEAL

Figure 7. Sectional Assembly Drawing
19/(20 blank)

This page left intentionally blank.

This page left intentionally blank.



Carver Pump Company

2415 Park Avenue • Muscatine, IA 52761

Phone: 563.263.3410 • Fax: 563.262.0510

www.carverpump.com

**I-381
MARCH 2016**