

BELOIT-JONES

DD 4000 REFINERS

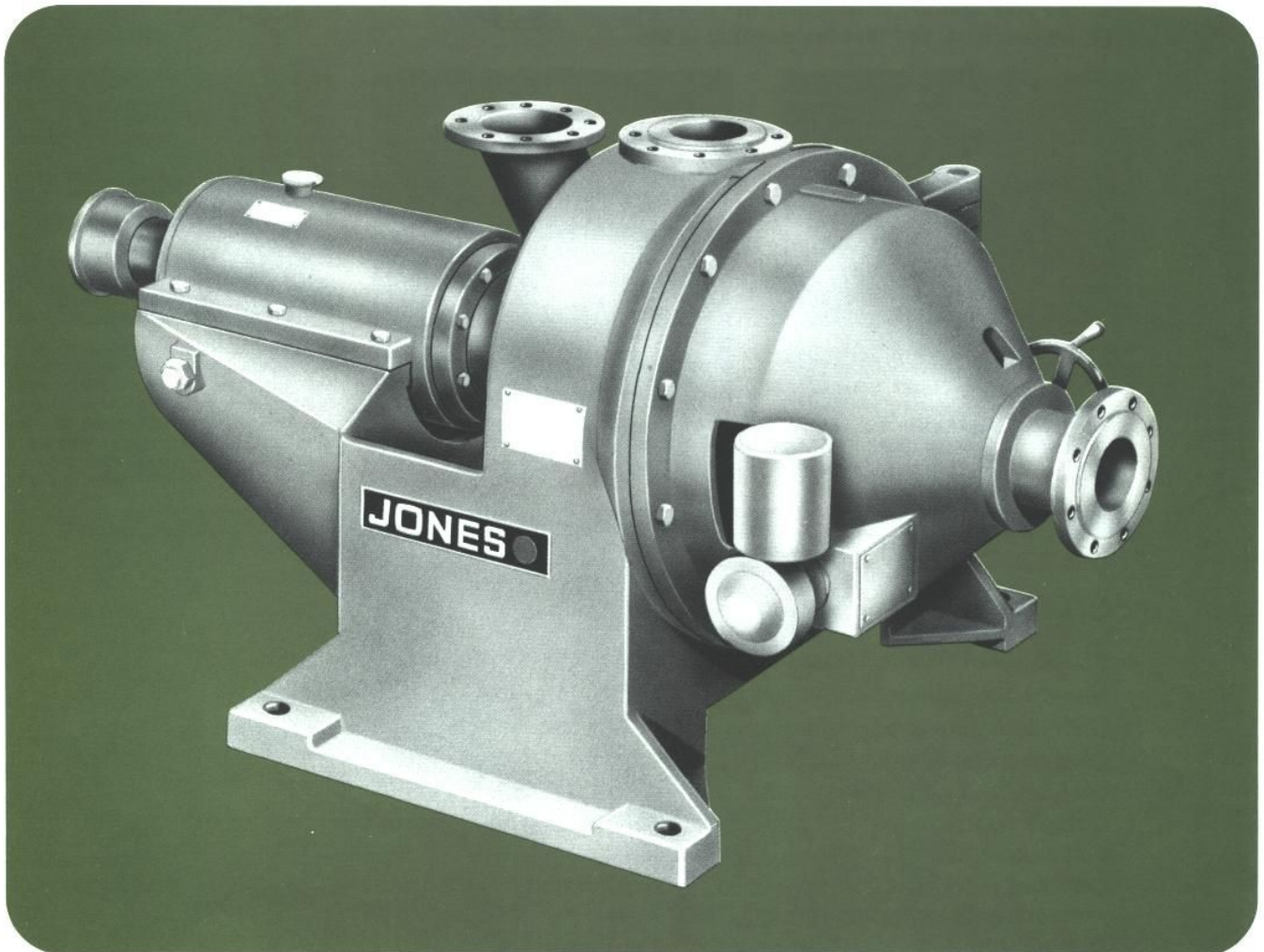

with optional
Monoflo/Duoflo design

Beloit Jones DD 4000 Refiners

Beloit Jones DD 4000 refiners are manufactured specifically for pulp or paper mill operation. They are equipped with an electromechanical positive-action plate position-

ing system which is an extremely accurate, dependable, and stable system for uniform processing of stock.

Simple Duoflo Operation

Duoflo application employs a spoked rotor which permits half of the incoming stock to pass through to the eye of the second set of disks. Stock passes in parallel across both sets of disks, rejoins, and leaves the unit through a single outlet.

This innovation from Beloit Jones requires only two pipes—inlet and outlet—for Duoflo operation, with the advantage that pipe disconnects are unnecessary during plate inspection or plate changes.

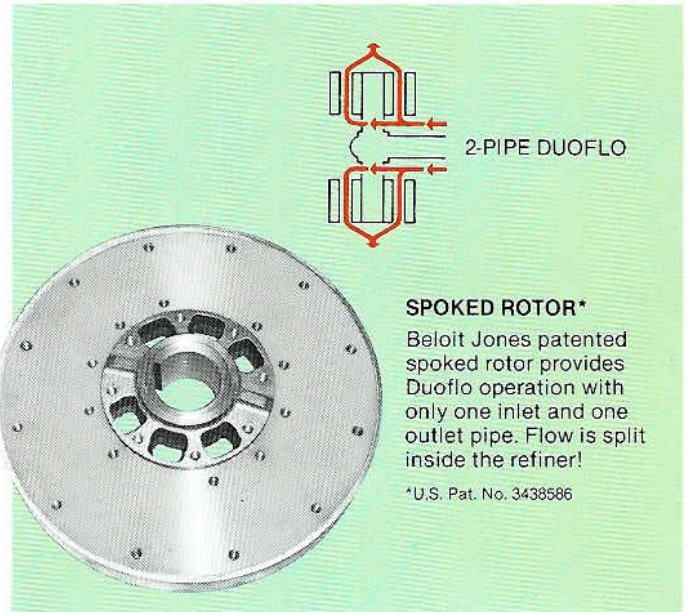

SPOKED ROTOR*

Beloit Jones patented spoked rotor provides Duoflo operation with only one inlet and one outlet pipe. Flow is split inside the refiner!

*U.S. Pat. No. 3438586

BELOIT JONES DD 4000 DUOFLO ARRANGEMENT

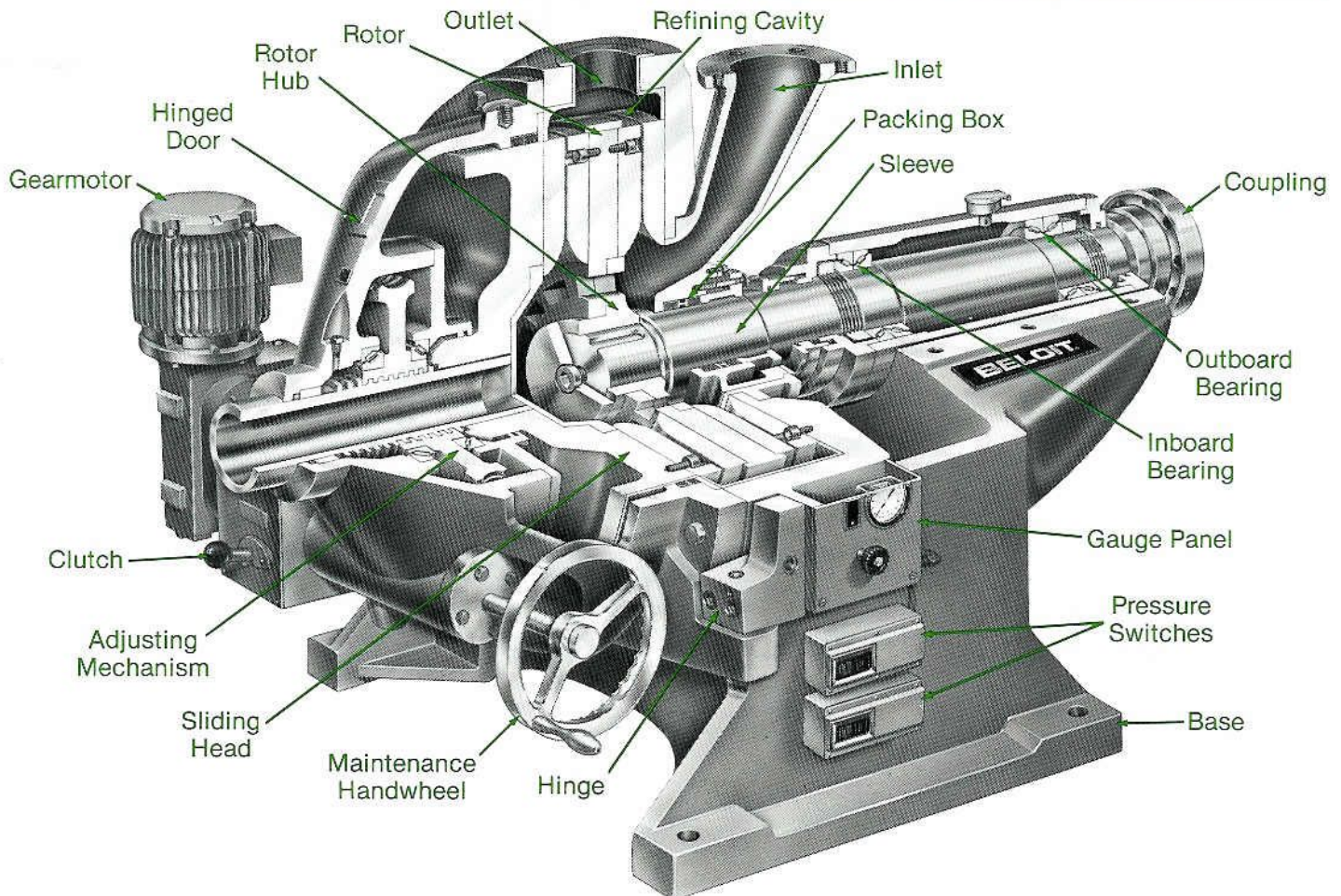

Features

- Full range of high technology cast and machined plates available in a variety of alloys.
- Scientific plate designs provide unit responsibility for optimum fiber treatment.
- Simplicity of design for ease of installation, operation and maintenance.
- Hinged end housing for easy access to plates.
- Two-pipe Duoflo with single stock inlet eliminates the need to disconnect piping for plate inspection or replacement.
- Easily accessible and replaceable packing box.
- Multiple plate diameters available in each basic size.
- Single post adjustment insures plate parallelism.
- Centered top outlet.
- Plate sizes available from 14" to 54".
- Optional automatic rotor centering device for controlled startup and shutdown protection of plates for longer life.
- A full range of automatic programmable refiner controls (PRC) is available.

Instrument panel—Mounted on the side of the refiner. Complete with inlet and outlet stock pressure gauges, a gland water gauge, and a gland water pressure control valve. All connections are terminated near the bottom of the panel and are tagged for easy mill connections.

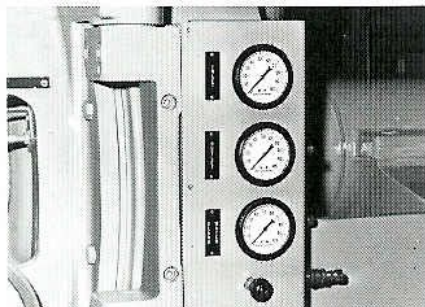

Available options—Include the optional rotor centering device for controlled start-up and shutdown.

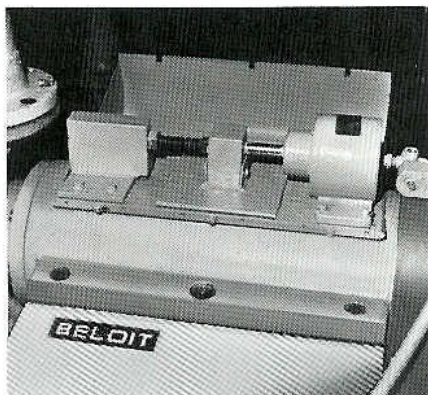

Limit switch and position indicator—Are mounted in the end housing and limit the back off travel of the sliding head. An adjustable rod actuates the limit switch and can be adjusted to compensate for disk wear. A pointer indicates the position of the sliding head on a graduated scale.

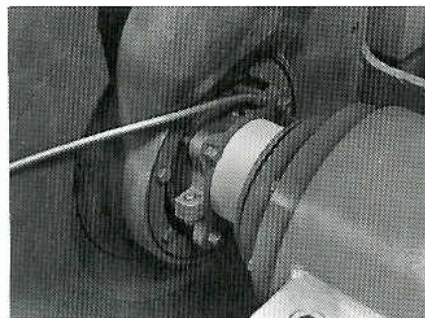
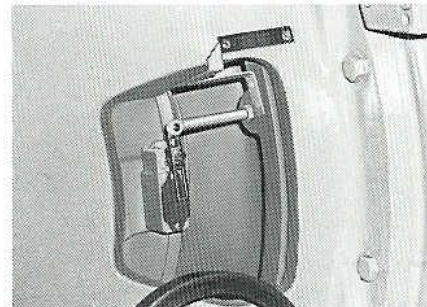

Accessible packing box—The replaceable stationary packing box is conveniently located on the refiner base. It is easily accessible and requires no flexible connections. The packing is lubricated by pressurized water through a lantern ring between packing rings.

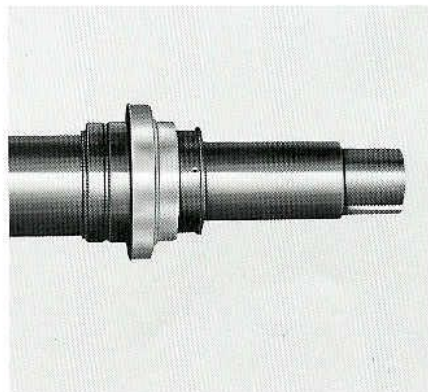

Packing sleeve—The packing sleeve is centrifugally cast Type 316S/S, coated with ceramic and given a precision polish. Alternate sleeve materials are available.

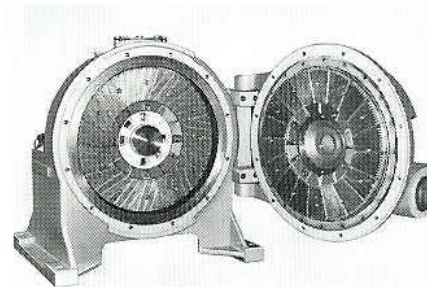

Hinged end housing—Plate access is a hinged end housing which contains the adjusting mechanism and sliding head assembly. Plates shown are one-piece design. Segmental overlap plates are also available.

Beloit Jones DD 4000 Refiners

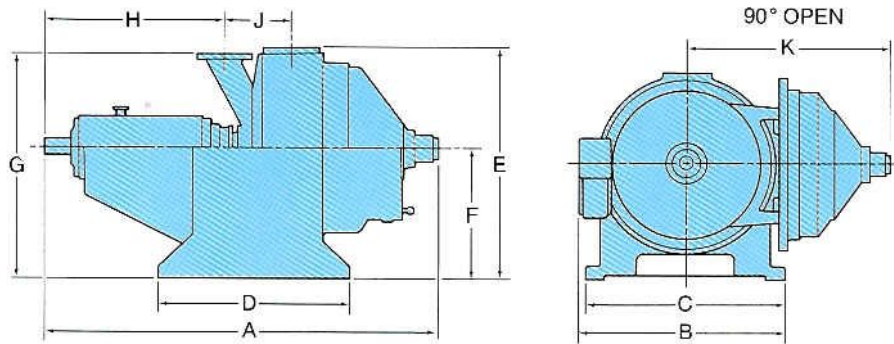

General Dimensions

(Inches, not to be used for construction.)

SIZE	INLET	DUOFLO OUTLET	A	B	C	D	E	F	G	H	J	K
16	3	3	54	32	26.5	24	26.8	15	21.4	24.2	7.8	32
20/24	4	4	70	42.8	38	30	39	22	29	32.8	11	40
26/30	6	6	80	48.2	45	38	46.5	26	44.2	39.4	12.8	52
34/38	6	6	90.3	56	53	42	56.5	32	55.5	42.3	12.8	55
38H*	8	8	90.3	56	53	42	61.3	32	56	41.3	13.8	52.8
42/46	8	8	117	65	63	48	65	36	63.5	54	15.8	71
46H*	10	10	117	65	63	48	69.5	36	67.5	52	17.4	71
54	12	12	148	77	63	79.2	76	36	72	82.5	19.5	82

*High-capacity units available for high flow capacity.

Specifications

SIZE		16	20	24	26	30	34	38	38H	42	46	46H	54
Nominal Capacity Range-Duoflo	T/D	5-50	25-100	25-150	35-300	35-350	65-400	65-500	65-650	100-800	125-900	125-1100	150-1500
Connected Power Range	HP	75-200	150-300	150-400	250-450	250-600	350-800	350-1000	350-1000	700-1750	700-2000	700-2000	1500-3000
Speed Range	RPM	900-1800	900-1200	720-900	720-900	600-720	514-720	514-600	514-600	450-600	450-514	450-514	360-450
Floor Space Required (Cx D)	IN	24 x 25	38.5 x 28	38.5 x 28	45 x 38	45 x 38	58 x 42	58 x 42	58 x 42	63 x 48	63 x 48	63 x 48	63 x 79
Shipping Weight	LB	2,100	4,400	4,400	7,400	7,400	11,500	11,500	11,500	20,000	20,000	20,000	30,000
Floor Loading	PSF	500	590	590	625	625	680	680	680	950	950	950	870
Casing Design Pressure	PSIG	100	100	100	100	100	100	100	100	100	100	100	100

Each model includes the complete machine as specified below, less motor and disks.

MODEL	4100 STANDARD	4200 CORROSION RESISTANT	4300 SPECIAL CORROSION RESISTANT
Sliding Head and Base	304 S/S Lined	304 S/S Lined	316 S/S Lined
Inlet Connection	Ductile Iron	304 S/S	316 S/S
Packing Box Water Lubricated	Ductile Iron Replaceable sleeves on shaft	304 S/S Replaceable sleeves on shaft	316 S/S Replaceable sleeves on shaft
Outlet Connection	304 S/S	304 S/S	316 S/S
Internal Construction	304 S/S	304 S/S	316 S/S
Main Shaft Bearings	Tapered roller		
Coupling	Gear Tooth Slide		
Adjustment	2-speed gearmotor complete with drive and limit switch		
Main Bearing Lubrication	Oil Bath (Circulating Oil System Available)		
Integral Panel	3 pressure gauges for inlet and outlet stock and packing box water. Includes seal water control valve and pressure switch.		
Grease Fittings	Pressure Type		
Gauge Connections	Brought to a single terminal area on the unit.		
Operator Controls	Remote manual operation cabinet, suitable for pipestand mount, complete with indicator, pushbuttons and lights. Switchgear, relays and control components in separate cabinet for mounting in main motor control center.		

BELOIT

JONES DIVISION, BELOIT CORPORATION, DALTON, MASSACHUSETTS, U.S.A. 01226
IN CANADA: JONES DIVISION, BELOIT CANADA LTEE/LTD., POINTE-CLAIRE, QUEBEC H9R 1G6