



Durco[®] Mark 3[™] *ASME (ANSI) Chemical Process Pump*

Mark 3 Standard • Sealmatic • Lo-Flo[™]
Recessed Impeller • Unitized Self-Primer



Experience In Motion

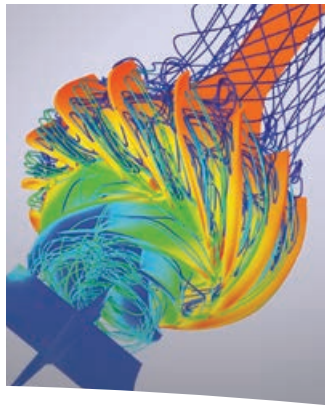

Pump Supplier to the World

Flowserve is the driving force in the global industrial pump marketplace. No other pump company in the world has the depth or breadth of expertise in the successful application of pre-engineered, engineered, and special purpose pumps and systems.

Life Cycle Cost Solutions

Flowserve is providing pumping solutions which permit customers to reduce total life cycle costs and improve productivity, profitability and pumping system reliability.

Market-Focused Customer Support

Product and industry specialists develop effective proposals and solutions directed toward market and customer preferences. They offer technical advice and assistance throughout each stage of the product life cycle, beginning with the inquiry.

Broad Product Lines

Flowserve offers a wide range of complementary pump types, from pre-engineered process pumps, to highly engineered and special purpose pumps and systems. Pumps are built to recognized global standards and customer specifications.

Pump designs include:

- Single-stage process
- Between bearings single-stage
- Between bearings multistage
- Vertical
- Submersible motor
- Positive displacement
- Nuclear
- Specialty

Product Brands of Distinction

ACEC™

Aldrich™

Byron Jackson®

Calder™ Energy Recovery Devices

Cameron™

Durco®

Flowserve®

HALBERG™

IDP®

INNOMAG®

Lawrence Pumps®

Niigata Worthington™

Pacific®

Pleuger®

Scienco™

Sier-Bath®

SIHI®

TKL™

United Centrifugal®

Western Land Roller™

Wilson-Snyder®

Worthington®

Worthington Simpson™

**Durco Mark 3
Family of ASME
(ANSI) Chemical
Process Pumps**

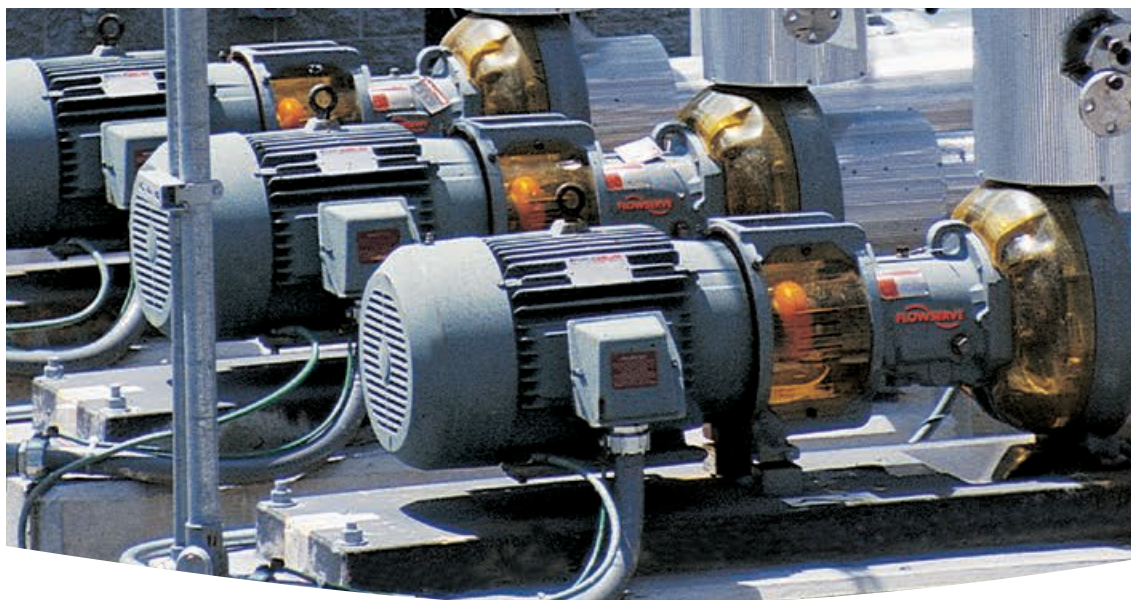

**The Premier Name in ASME (ANSI)
Chemical Process Pumps**

The Durco Mark 3 chemical process pump provides outstanding hydraulic performance, unrivaled reliability and low total cost of ownership. Conforming to ASME (ANSI) B73.1, the Durco Mark 3 incorporates many proven reliability- and performance-enhancing features. The resultant benefits are:

- *Renewable, high-efficiency performance over the life of the pump with the reverse vane impeller*
- *Optimal, predictable seal chamber pressures that are re-established after every impeller setting*
- *Maximal mechanical seal life due to an ideal seal environment created by the SealSentry™ seal chamber*
- *Robust shaft and bearing designs that minimize shaft deflection and extend mechanical seal and bearing life*
- *Fast and accurate impeller setting with the industry's most innovative external impeller adjustment mechanism*
- *In-shop reverse vane impeller adjustment with the only pump that takes full advantage of the back pull-out design*

Breadth of Pumping Solutions

The Mark 3 family of ASME (ANSI) chemical process pumps offers a wide range of configurations, including mechanically sealed, dynamically sealed, sealless magnetically driven, low-flow, self-priming and recessed impeller. The Mark 3 family, therefore, provides flexibility and breadth of pumping solutions in countless applications throughout the worldwide infrastructure markets.

Typical Applications

- Acid transfer
- Brine
- Chemical processing
- Petrochemical processing
- Corrosive services
- Food and beverage processing
- Hydrocarbon processing
- Pharmaceuticals
- Polymers
- Pulp and paper
- Seawater
- Slurries
- Solvents
- Steel and primary metals
- Water and wastewater treatment

Table of Contents

Durco Mark 3 ASME (ANSI) Standard Pump..... 4–5

Performance Curves 6

Interchangeability..... 7

Power Ends 8–9

Shafts and Bearings..... 10–11

SealSentry Seal Chambers..... 12–13

Impellers..... 14–15

IPS Beacon™ Condition Monitor..... 16

Materials of Construction..... 17

Options to Solve Application Problems 18–19

Baseplates..... 20–23

Durco Mark 3 Lo-Flo™ Pump 24–25

Durco Mark 3 Sealmatic Pump 26–27

Durco Mark 3 Unitized Self-Priming Pump..... 28–29

Durco Recessed Impeller Pump 30–31

Complementary Pumps 32–34

Durco Mark 3
ASME (ANSI) Standard
Chemical Process Pump

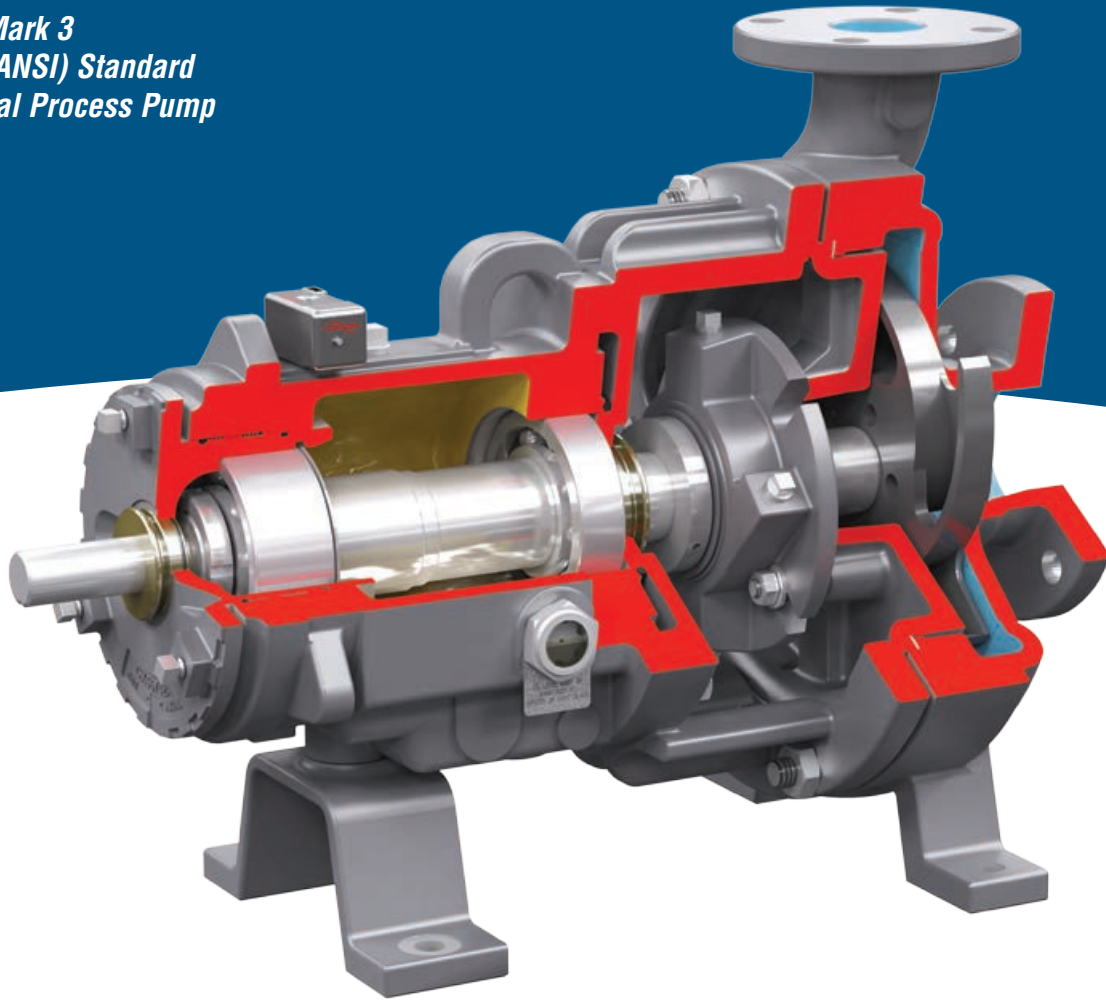

The Durco Mark 3 pump is recognized worldwide as the premier name in ASME (ANSI) chemical process pumps. Conforming to ASME (ANSI) B73.1 and incorporating many advanced design features, the rugged Mark 3 pump provides unmatched performance and reliability while minimizing the total cost of ownership. The Durco Mark 3 is CE marked and compliant with applicable directives such as ATEX.

Operating Parameters

- Flows to 4540 m³/h (20 000 US gpm)
- Heads to 215 m (700 ft)
- Pressures to 27 bar (400 psi)
- Temperatures from -73°C (-100°F) to 370°C (700°F)
- Discharge sizes from 25 mm (1 in) to 200 (8 in)

36 Sizes Available

- Seven Group 1
- 16 Group 2
- Seven Group 3
- Six Group 4¹

¹ Group 4 is not an official ASME (ANSI) B73.1 designation.

Features and Benefits

Unique Reverse Vane Impeller is the only impeller design that offers repeatable pump performance throughout the life of the pump. Open impellers are available.

SealSentry Seal Chambers feature innovative flow modifiers to extend seal life and provide advanced self-flushing capability.

External Micrometer Impeller Adjustment accurately sets impeller clearance in 20 seconds, in the shop or in the field.

Largest Shaft and Bearing Components in standard ASME pumps extend bearing life and reduce shaft deflection and vibration.

Back Pull-out Design allows removal of rotating element without removing casing, piping or motor.

Heavy-duty Pump End and Drive End Bearings are selected for long life and reliability.

Typical Applications

- Acid transfer
- Caustic and chlor-alkali
- Man-made fibers
- Polymers
- Slurry processing
- Solvents
- Volatile organic compounds
- Waste processing



Reverse Vane Impeller Lowers Total Cost of Pump Ownership

The Durco Mark 3 pump features a reverse vane impeller for unequaled efficiency and performance. This exclusive Durco design lowers the total cost of pump ownership by easing maintenance and extending bearing and seal life.

- Low, predictable seal chamber pressure and thrust loads
- Lowest required NPSH of any ASME (ANSI) standard pump
- Abrasive wear is on the rear cover rather than the more expensive casing.
- In-shop impeller adjustment with the only impeller design that takes full advantage of the back pull-out feature
- Repeatable performance assurance



SealSentry Seal Chamber Technology Helps the Bottom Line

The Durco Mark 3 incorporates SealSentry seal chamber technology. These Vaalar Award-winning seal chambers feature unique flow modifiers (FM) which reduce pump operating costs and increase pump availability by:

- Improving mechanical seal performance, reliability and life
- Reducing maintenance and repair costs
- Enabling the use of less costly seals and flush plans

Truest Running ASME (ANSI) Pump

The Mark 3 standard pump is engineered with four precision-machined, metal-to-metal fit locations — more than any other.

- Precision-machined, metal-to-metal bearing carrier reduces tolerance stack-ups to improve shaft concentricity.
- Superior to jackscrew designs which can cause cocking
- Extends bearing and mechanical seal life

Choice of Power Ends

- Standard Mark 3A power end with double lip oil seals and top vent/breather
- ANSI 3A™ power end (shown on page 8) featuring Inpro VBXX bearing isolators and a lifetime warranty

**Durco Mark 3
Performance Curves²**

Affinity™ Pump Selection Application

Affinity is a state-of-the art pump selection program from Flowserve. This Web-based tool delivers immediate, real-time access to the latest, most accurate data about Flowserve pumps. Use it to size a pump for a new application or get performance information for an existing installed unit. Users can also save selections for future reference and generate technical documents specific to their hydraulic selection. Affinity can be accessed at www.flowserve.com/affinity.

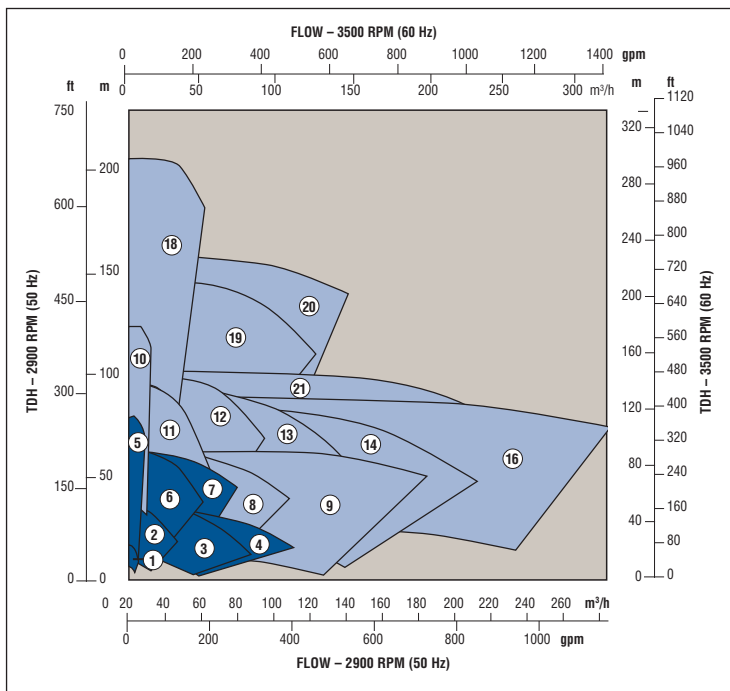

Mark 3 Standard Group 1

- ① 1½x1LF-4
- ② 1½x1-6
- ③ 3x1½-6
- ④ 3x2-6
- ⑤ 1½x1LF-8
- ⑥ 1½x1-8
- ⑦ 3x1½-8

Mark 3 Standard Group 2

- ⑧ 3x2-8
- ⑨ 4x3-8
- ⑩ 2x1LF-10
- ⑪ 2x1-10A
- ⑫ 3x1½-10A
- ⑬ 3x2-10A
- ⑭ 4x3-10
- ⑮ 4x3-10H
- ⑯ 6x4-10
- ⑰ 6x4-10H
- ⑱ 3x1½LF-13
- ⑲ 3x1½-13
- ⑳ 3x2-13
- ㉑ 4x3-13
- ㉒ 4x3-13HH
- ㉓ 6x4-13A

Mark 3 Standard Group 3

- ⑳ 8x6-14A
- ㉑ 10x8-14
- ㉒ 6x4-16
- ㉓ 8x6-16A
- ㉔ 10x8-16
- ㉕ 10x8-16H
- ㉖ 10x8-17³

² Higher flows available with Mark 3, Group 4 pump. Please see Bulletin PSS-10-13.2 for more information.

³ Max. speed: 1450 rpm

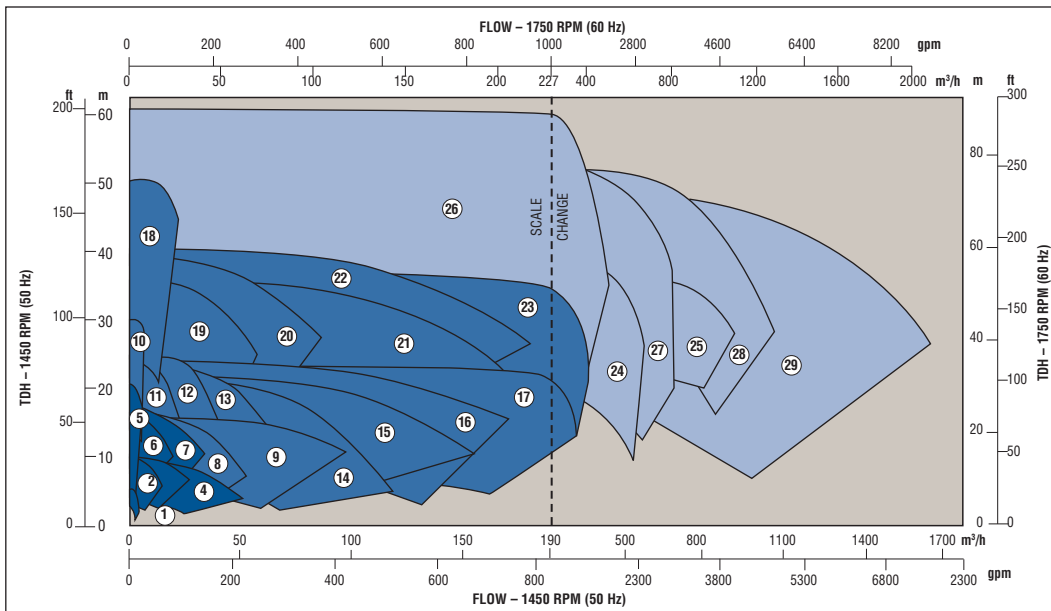

Durco Mark 3 Parts Interchangeability



Extraordinary Interchangeability

With only three different power frames and five SealSentry seal chamber options, the 30 pumps in the Durco Mark 3 family offer a high degree of parts interchangeability.

Pumps delivered worldwide are manufactured in ISO 9001 certified Flowserve facilities.



Quality System Certificate

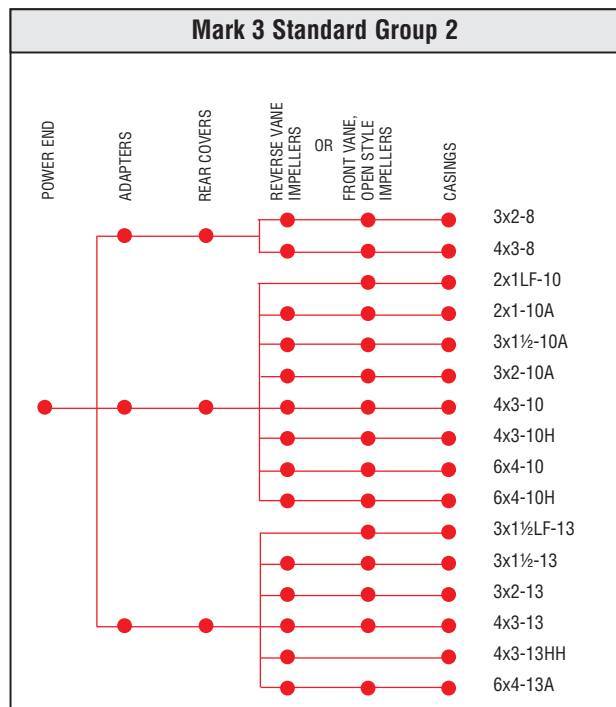
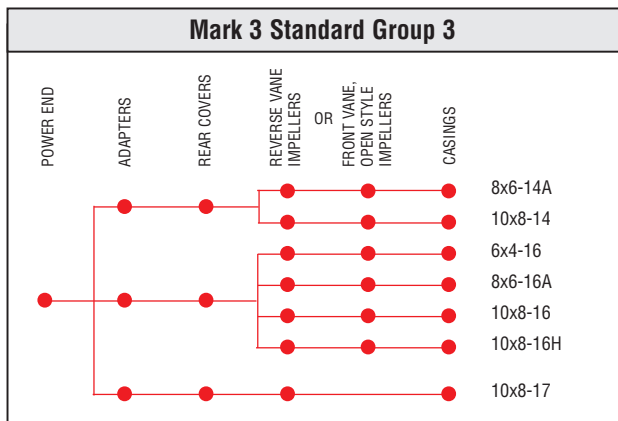
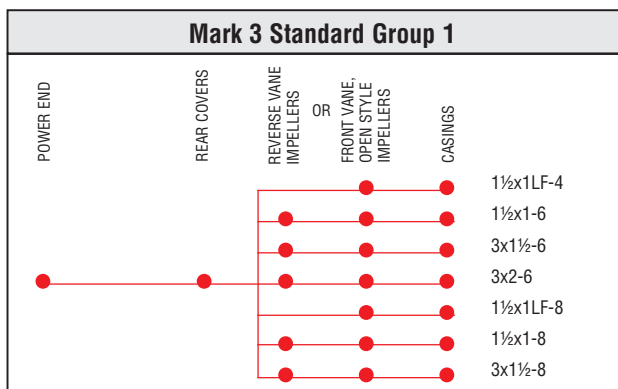

Durco Mark 3 Power Ends

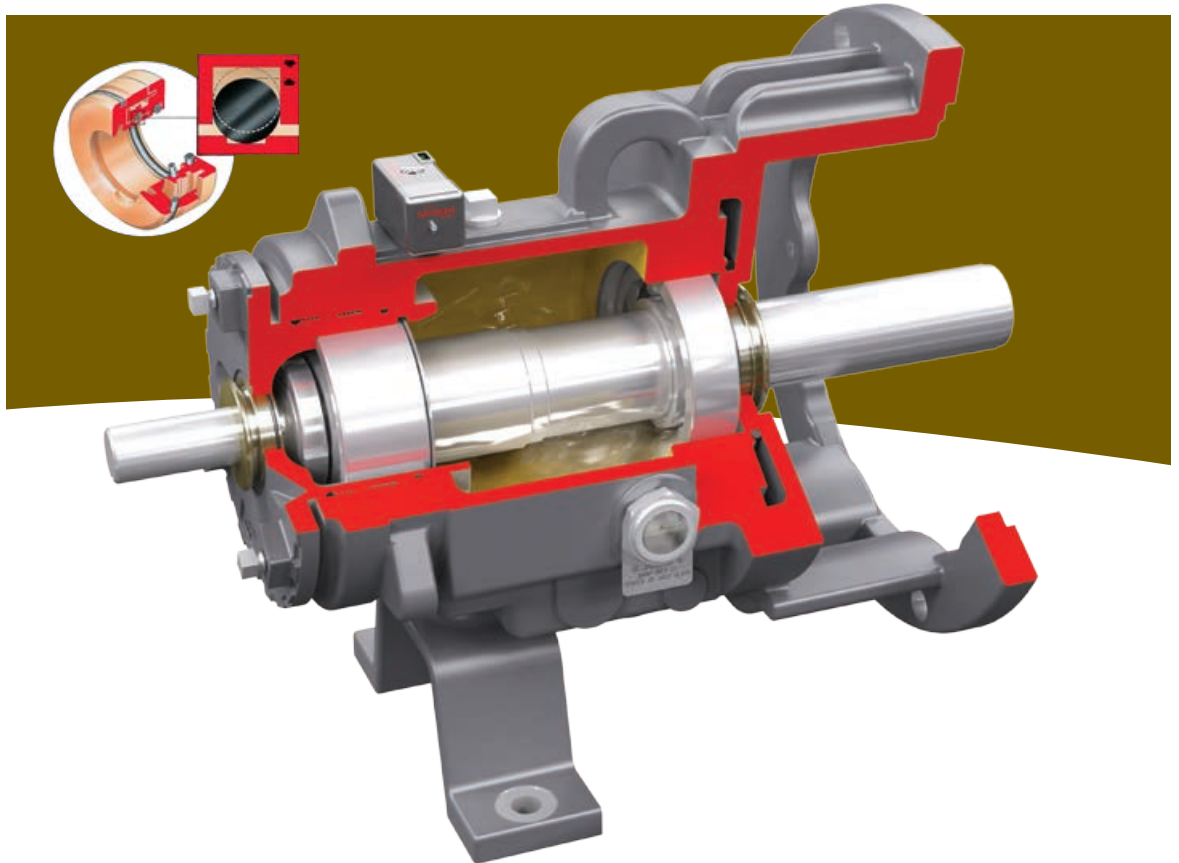

Flowserve offers the Durco Mark 3 pump with a choice of power ends: the standard Mark 3A or the optional ANSI 3A (shown).

Standard Mark 3A Power End

The Mark 3A power end features numerous reliability-, maintenance- and performance-enhancing features, including:

- Double row angular contact outboard and single row, deep groove inboard bearings provide excellent axial and radial load support.
- External micrometer enables accurate impeller clearance setting in 20 seconds, restoring pump efficiency.
 - Superior to jackscrews
 - Protected with O-rings
- ASME (ANSI) B73.1 ductile iron frame adapter provides strength and facilitates interchangeability.
- Metal-to-metal construction assures a true running and concentric shaft, extending bearing and mechanical seal life.
- Critical shaft surfaces ground to 0.4 micron (16 μ in) finish to ensure secondary sealing ability of the mechanical seals.
- Double lip oil seals
- Top mounted vent and oil filler
- Trico WATCHDOG® constant level oiler with integral viewpoint
- Optional magnetic drain plug
- Optional oil slinger

Optional ANSI 3A Power End

The ANSI 3A power end is so advanced it carries a lifetime warranty.⁴ It offers the same reliability and performance-enhancing features as the standard Mark 3A power end but also includes:

- Certified clean room assembly
- Inpro Seal's VBXX non-contact Vapor Block Bearing Isolators keep lubricants in and contaminants out.
- Top vent replaced with plug
- Lubrication options
 - Oil mist systems
 - Shielded and grease-lubricated bearings (three-year bearing guarantee)
- Rigid foot design

⁴ Note: Adherence to proper installation, operation and maintenance procedures is necessary for lifetime warranty. Contact your Flowserve representative for detailed terms and conditions.

Micrometer Impeller Adjustment



Unique External Micrometer Reduces Maintenance Time and Costs

Durco's innovative external micrometer impeller adjustment mechanism is simple to use and reduces maintenance time and costs. Most importantly, though, it is precisely accurate.



Step 1: Loosen the setscrews. Using a wrench, rotate the bearing carrier counterclockwise until the impeller lightly touches the rear cover plate.



Step 2: Select the impeller setting. Each notch on the carrier ring represents exactly 0.10 mm (0.004 in) of clearance. For an impeller setting of 0.5 mm (0.020 in), count five notches counterclockwise.



Step 3: Move the carrier clockwise the selected number of notches. Tighten the setscrews and check the impeller clearance with the feeler gauge.

Durco Mark 3 Shafts and Sleeves⁵

-
- ① Radiused “sled-runner” keyways improve strength at this stress point.
 - ② Offset keyways aid shaft balance.
 - ③ Alloy identification on every shaft and sleeve ensures that the right parts go in every time.
 - ④ Large radii fillets add strength.
 - ⑤ Accurate machining under bearings ensures perfect bearing fits without vibration or hot running.
 - ⑥ Run-out of 0.03 mm (<0.001 in) at mechanical seal allows seal faces to run true.
 - ⑦ Critical surfaces ground to a surface finish of 0.4 micron (16 μin) ensure the secondary sealing ability of mechanical seals.
 - ⑧ Steel power ends handle higher horsepower loads than stainless.
 - ⑨ Minimally radiused edges ensure full contact with impeller for reduced run-out.

Several Shaft and Sleeve Options

Durco Mark 3 shafts and sleeves are designed to improve pump reliability and performance. Shafts and sleeves are available in numerous materials to suit application needs.



Friction-welded: a steel power end friction-welded to a solid alloy wet end



Composite: a steel shaft end-to-end with an integral (i.e., not replaceable) sleeve of DC8, SD77 high silicon iron, ceramic (alumina or zirconia)



Solid: steel end-to-end or stainless alloy end-to-end



Hook Sleeve: a steel shaft end-to-end or a steel power end friction-welded to a stainless wet end accommodating a hook sleeve

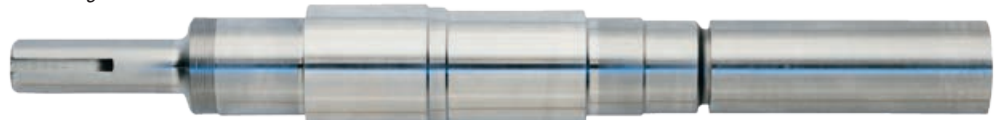

⁵ Flowserve recommends the use of solid shafts rather than shaft sleeves to reduce the harmful effects of deflection and vibration. Shaft sleeves may simplify maintenance, but solid shafts reduce it.

Durco Mark 3 Heavy-Duty Shaft and Bearings

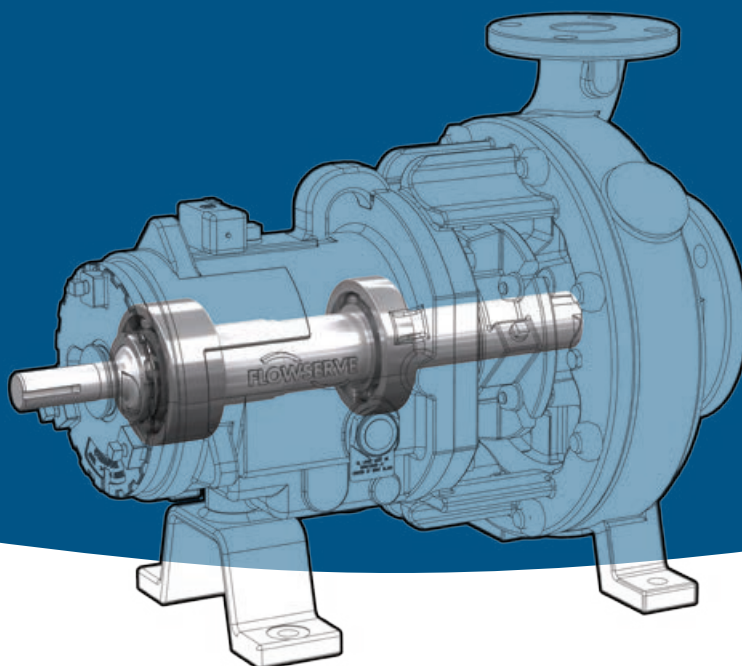

Unrivaled Shaft and Bearing Design

The Durco Mark 3 shaft and bearings system is designed to improve pump performance and reliability. In fact, FlowsERVE offers the largest shaft and bearing components available in ASME (ANSI) standard pumps. A comparison of the Durco Mark 3 Group 2 power end with that of a major competitor demonstrates the benefits of heavy-duty design.

Bearings

The dynamic load rating for the Durco Mark 3 pump is indicated in Table 1. A greater dynamic load rating translates into extended bearing life. A comparison of extended bearing life reveals Durco Mark 3 bearings are designed to last up to 61% longer.

Shaft

The deflection index⁶ provides an approximate comparison of shaft stiffness. The lower the value, the better a shaft's ability to resist deflection. Durco Mark 3 shafts provide 43% to 252% greater stiffness. This results in superior pump performance and reliability. (See Table 2.)

⁶ The deflection index formula is $I = L^3/D^4$ where: I = index of deflection; L = length of shaft overhang from bearing; and D = rigid shaft diameter. While this index can provide an approximate comparison of shaft stiffness, a detailed analysis should be made to determine actual shaft deflection.

Table 1: Bearing Comparison

| Group 2 | I. B. Bearing | Dynamic Load Rating | O. B. Bearing | Dynamic Load Rating |
|------------------|---------------|------------------------|---------------|------------------------|
| FlowsERVE | 6310 | 6078 kg (13 400 lb) | 5310 | 8709 kg (19 200 lb) |
| Major Competitor | 6309 | 5398 kg (11 900 lb) | 5309 | 7439 kg (16 400 lb) |

Extended Bearing Life Comparison

$$I.B. = \left| \frac{6078}{5398} \right|^3 = 1.43 (+43\%) \quad O.B. = \left| \frac{8709}{7439} \right|^3 = 1.61 (+61\%)$$

Table 2: Deflection Comparison

| Group 2 | Overhang Length | Solid Shaft | | Sleeve | |
|------------------|----------------------|---------------------|------------------|-------------------|------------------|
| | | Shaft Diameter | Deflection Index | Shaft Diameter | Deflection Index |
| FlowsERVE | 189 mm (7.687 in) | 48 mm (1.875 in) | 37 | 38 mm (1.5 in) | 90 |
| Major Competitor | 213 mm (8.375 in) | 45 mm (1.75 in) | 63 | 38 mm (1.5 in) | 116 |

**Durco Mark 3
SealSentry Seal
Chambers**

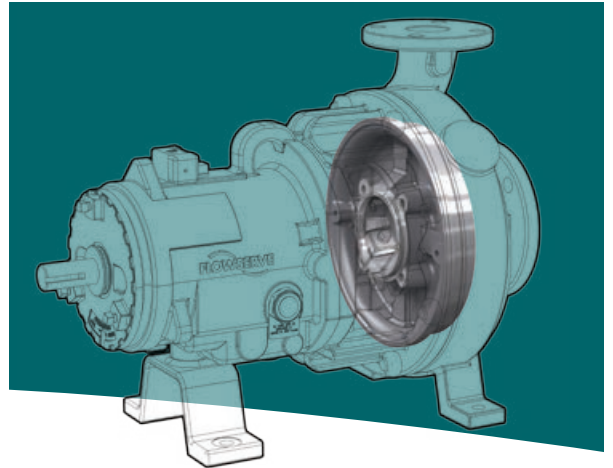

Advanced Seal Chamber Technology

Durco SealSentry seal chambers improve pump reliability and reduced total cost of ownership.

- Extends mechanical seal life
 - Self-flushing
 - Self-venting
 - Self-draining
- Reduces maintenance and repair costs
- Permits use of less expensive seals and flush plans; plans 11, 32, 52, 53, etc. can be eliminated
- Provides a safer environment for personnel

Flow Modifiers Extend Seal Life

- Flow modifiers redirect flow from circumferential to axial.
- Balanced flow with low-pressure drop in the chamber helps keep solids in suspension, minimizing erosion.
- The mechanical seal creates a centrifuging action away from its parts.
- Solids and slurry merge into the returning flow path and are flushed out of the seal chamber.

Jacketed Seal Chambers Available

Jacketed seal chambers are designed for effective heat transfer in the seal chamber area or across the entire surface area of the process fluid.

- Use the jacketed cylindrical bore when seal chamber cooling is the objective
- Use the jacketed FM seal chamber when protection of the process temperature is important

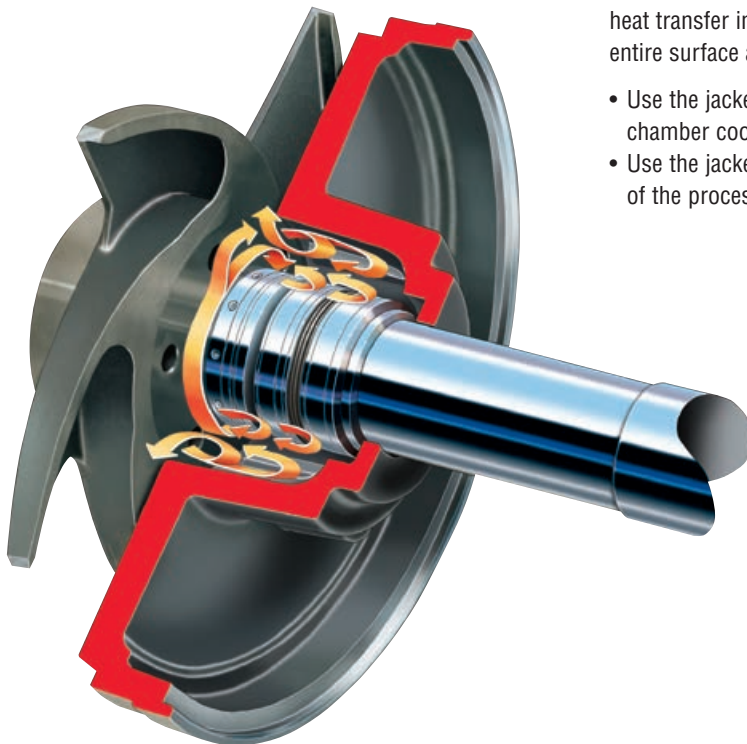

Durco SealSentry seal chambers extend seal life, improve pump reliability and reduce the total cost of pump ownership.

FML

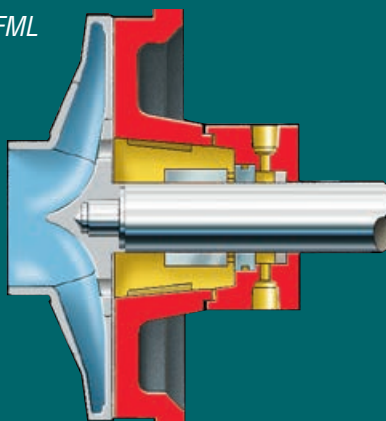

CBL

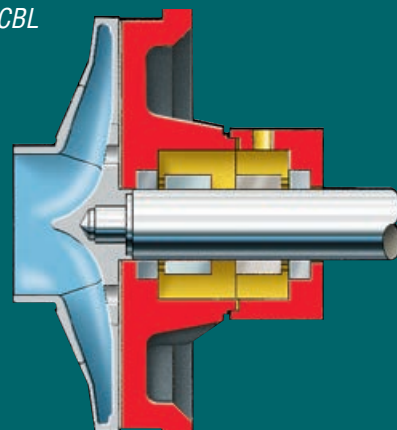

Multiple Designs to Suit Requirements

The SealSentry family of seal chambers offers three FM (flow modifier) and two cylindrical bore (CB) options.

Flow Modifier Designs

FML (shown above) — Designed with a large gland bolt and gasket circle, the FML is preferred for most applications:

- Single internal cartridge seals
- Dual internal/external cartridge seals
- Single internal component seals with flexibly mounted seats
- Dual internal “true” tandem design cartridge seals

FMS — Similar to the FML, the FMS accommodates seals with small gland bolt and gasket circles. It is ideal for all mounting configurations of single seals.

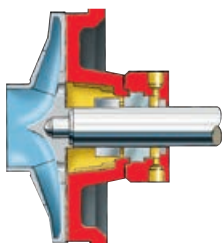

FMI — The FMI incorporates a cast-in integral gland. It utilizes the shaft sleeve for seal setting and fast installation. It may be used with:

- Single internal, flexibly mounted seals
- Sanitary-type applications

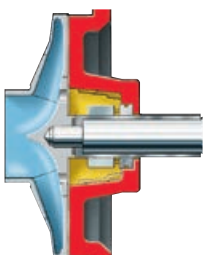

Cylindrical Bore Designs

CBL (shown above) — With an oversized cylindrical step bore, the CBL is ideal for seals with large gland bolt and gasket circles. It may be used with:

- Dual internal component seals that isolate the seal chamber from the process with external barrier fluid
- Single seal with throttle bushing and flush to boost pressure over flash point

CBS — The CBS is designed for packing arrangements and conventional seals with small gland bolt and gasket circles.

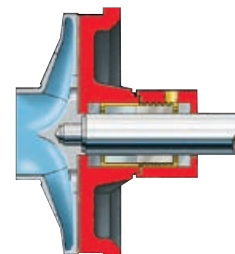

SealSentry Nomenclature

| | |
|-----|---|
| FML | Flow modifier, large gland bolt circle |
| FMS | Flow modifier, small gland bolt circle |
| FMI | Flow modifier, integral gland bolt circle |
| CBL | Cylindrical bore, large gland bolt circle |
| CBS | Cylindrical bore, small gland bolt circle |

Durco Mark 3 Impellers

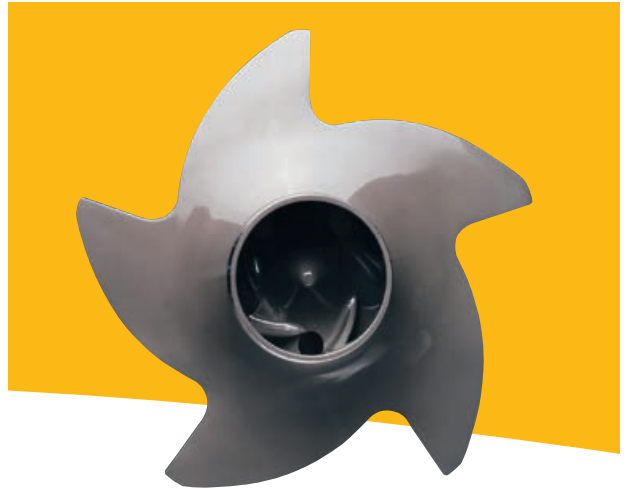
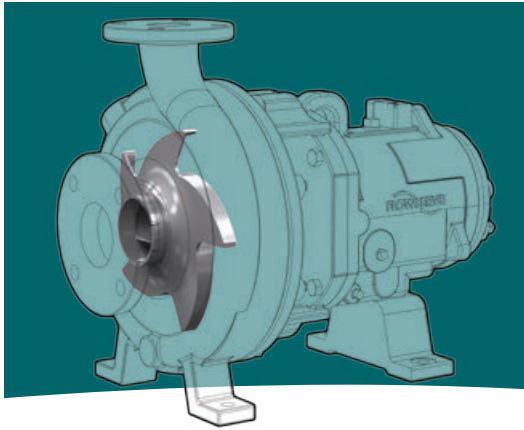

Exclusive Reverse Vane Impeller Offers Performance and Maintenance Advantages

The Durco reverse vane impeller with balance holes delivers excellent efficiency and performance, while extending bearing and seal life. The result is reduced total cost of pump ownership.

- **Predictable, Repeatable Seal Chamber Pressure and Thrust Loads** mean the mechanical seals last longer.
- **Lowest Required NPSH** of any standard pump
- **Rear Cover** takes the abrasive wear instead of the more expensive casing.
- **Easy Impeller Adjustment** — whether in the shop or in the field — with the only impeller design that takes full advantage of the back pull-out feature
- **In-shop Impeller Adjustment** with the only impeller design that takes full advantage of the back pull-out feature. Since the critical running clearance is set between the rear of the impeller and the rear cover plate, both impeller and mechanical seal settings can be done in the shop, “on the bench,” instead of under adverse field conditions.
- **Repeatable Performance Assurance** with the only impeller design that offers repeatable seal chamber pressures and bearing thrust loads

Low Predictable Seal Chamber pressure means longer seal life.

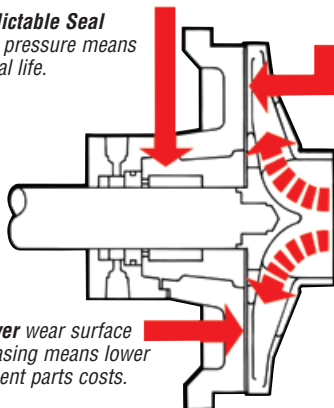

Clearance is set to the rear cover in the shop — not to the casing which is left in the piping.

Lowest Overall required NPSH of any ASME standard pump

Rear Cover wear surface versus casing means lower replacement parts costs.

External Micrometer Enables In-shop Impeller Adjustment

Durco’s unique external micrometer impeller adjustment mechanism is simple to use and reduces maintenance time. Most importantly, it is precisely accurate.



Available Front Vane, Open Style Impeller

The Durco Mark 3 is also available with an open style impeller. Fully interchangeable with the reverse vane impeller, the front vane, open style impeller is an excellent choice for fibrous, stringy materials and certain applications requiring high shear against the casing.

Low-flow and recessed impeller pump configurations are also available. See pages 24 and 30, respectively.

The Durco reverse vane impeller offers predictable, repeatable, like-new performance each time it is adjusted.

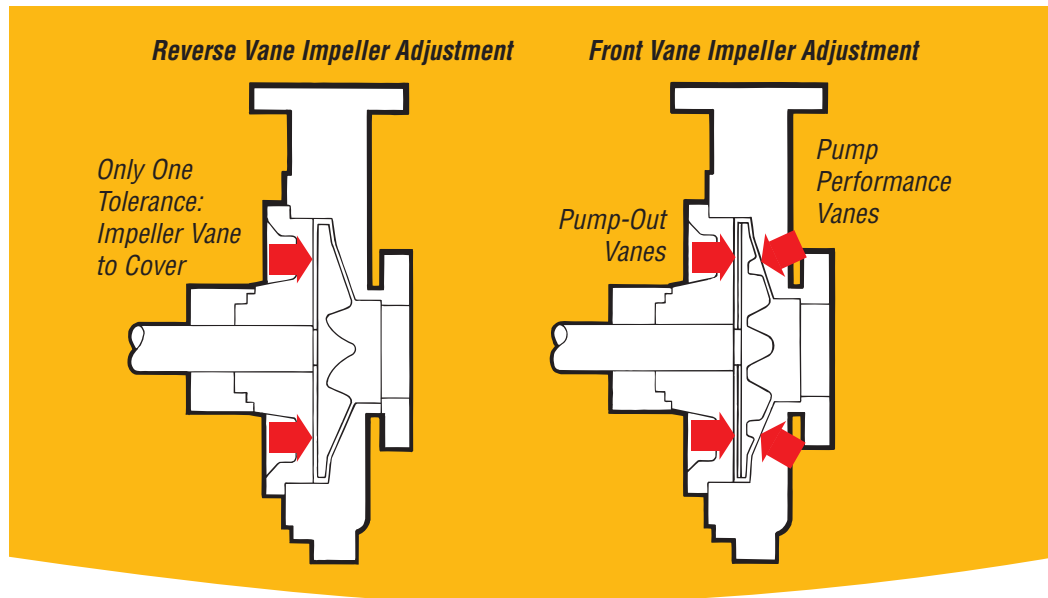

Predictable, Repeatable Performance

Unlike open impellers, Durco reverse vane impellers offer repeatable performance after wear and impeller adjustment.

Reverse Vane Impellers

A reverse vane impeller has only one set of pumping vanes and one critical tolerance. This single tolerance — between the impeller and the rear cover — establishes:

- Performance
- Efficiency
- Seal chamber pressure
- Thrust loads

Wear between the reverse vane impeller and the rear cover causes axial thrust loads to decrease as the seal chamber gap widens. At the same time, seal chamber pressure increases. By adjusting the setting of the reverse vane impeller against its single tolerance location, the original seal chamber pressure and axial thrust loads are re-established. The result is consistent, like-new performance.

Open Style Impeller

A front vane open style impeller has two sets of pumping vanes and two critical tolerance locations:

- The front vane clearance to the casing establishes:
 - Performance
 - Efficiency
- The pump out vanes clearance to the rear cover establishes:
 - Seal chamber pressures and seal life
 - Thrust loads and bearing life

Wear causes axial thrust loads and seal chamber pressure to increase as the seal chamber gap widens. But the impeller cannot be adjusted to both tolerance locations at the same time. Seal chamber pressure and bearing loads increase after each adjustment. Performance is diminished and seal and bearing life suffers as a result.

Effects of Wear and Impeller Readjustment

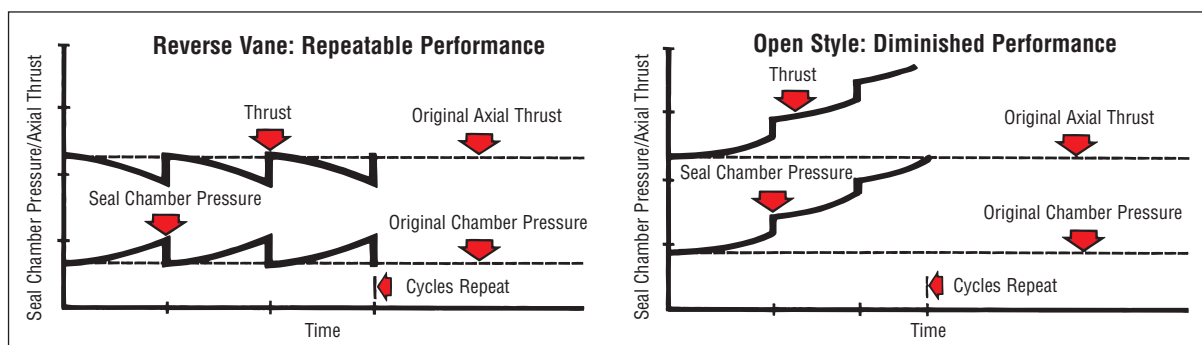

**Durco Mark 3
IPS Beacon™ Power
End Condition Monitor**

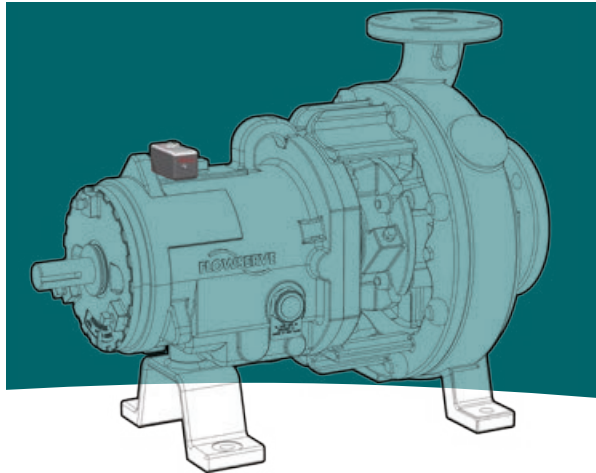

Continuous Monitoring for Improved Pump Reliability and Availability

All new Mark 3 pumps incorporate the IPS Beacon power end condition monitor. Mounted on top of the bearing housing, IPS Beacon is a light fault device that continuously monitors the bearings and provides a visual signal that a current or past alert condition has occurred. Borosilicate glass-protected LEDs indicate when thrust bearing temperature or vibration levels exceed set-point limits.

Specific capabilities include:

- Three-axis vibration measurement (velocity or acceleration)
- Temperature sensor — 0.01% full scale
- 14-day visual fault indication
- LED indications for normal operation, current alert condition and past alert condition
- Extended battery life — four years typical
- Certified design — CE Marked, ATEX/IECEX, CSA

IPS Beacon may be retrofitted to all existing Durco Mark 3 and Mark 3 ISO pumps as well as most process pumps.

Expansion Capabilities for More Advanced Monitoring Needs

IPS Beacon is available with a take away memory (TAM) device that has the ability to log and store monitoring data locally as well as adjust set-point limits. When used in combination with the accompanying docking device which interfaces with a customer's local PC, the TAM enables stored data to be displayed in Microsoft® Excel® for analysis.

Further expansion capabilities include integration of a multi-point monitoring device and continuous wireless monitoring functionality.



© Microsoft and Excel are registered trademarks of Microsoft Corporation.

**Durco Mark 3
Materials of
Construction**

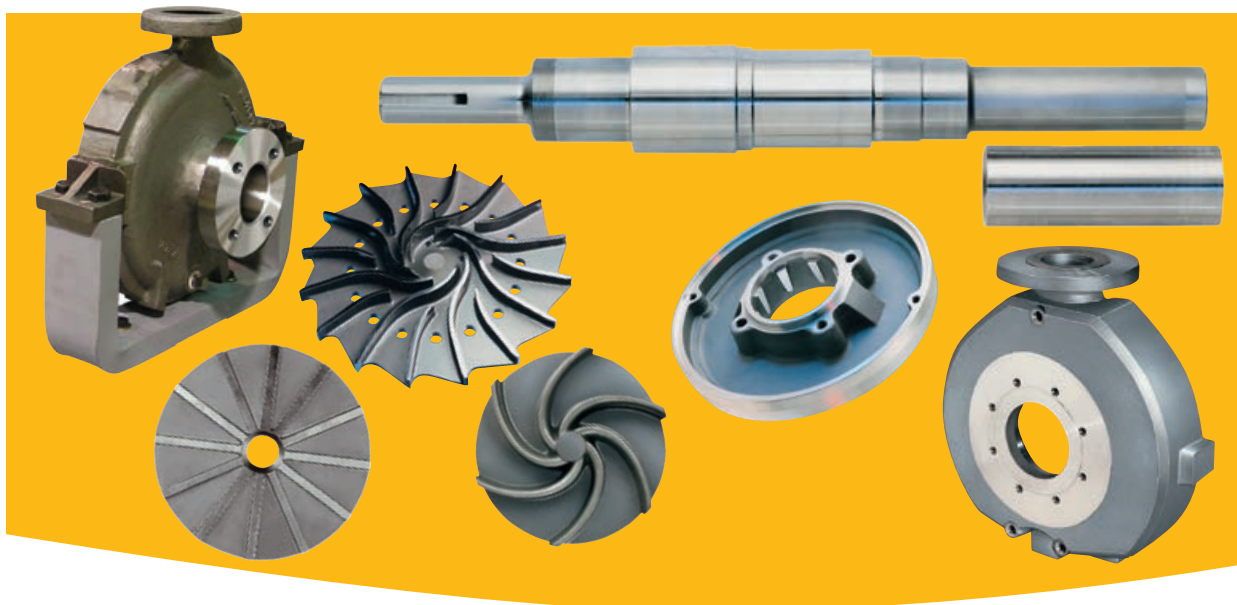

Flowserve foundries are widely regarded as among the best in the world, pouring alloys from ductile iron to stainless steels to light reactive alloys such as titanium. All wet-end Mark 3 castings carry a limited lifetime guarantee.

Standard Materials of Construction⁷

| Designation | Symbol | ACI Designation | Equivalent Wrought Designation | ASTM Specifications* |
|---------------------------|--------|-----------------|--------------------------------|----------------------|
| Ductile Iron | DCI | None | None | A395 |
| Carbon Steel | DS | None | Carbon Steel | A216 Gr. WCB |
| CF-8M | D4 | CF8M | 316 | A744, Gr. CF8M |
| Durcomet 100 | CD4M | CD4MCuN | Ferralium [®] 255 | A995, Gr. 1B |
| Durimet 20 | D20 | CN7M | Alloy 20 | A744, Gr. CN7M |
| Durcomet 5 | DV | None | None | None |
| CY-40 | DINC | CY40 | Inconel [®] 600 | A494, Gr. CY40 |
| M-35 | DM | M351 | Monel [®] 400 | A494, Gr. M35-1 |
| Nickel | DNI | CZ100 | Nickel 200 | A494, Gr. CZ100 |
| Chlorimet 2 | DC2 | N7M | Hastelloy [®] B-2 | A494, Gr. N7M |
| Chlorimet 3 | DC3 | CW6M | Hastelloy [®] C-276 | A494, Gr. CW6M |
| Duriron [®] | D | None | None | A518, Gr. 1 |
| Durichlor 51 [®] | D51 | None | None | A518, Gr. 2 |
| Superchlor [®] | SD77 | None | None | None |
| DC-8 | DC8 | None | None | None |
| Titanium | Ti | None | Titanium | B367, Gr. C-3 |
| Titanium-Pd | Ti-Pd | None | Titanium-Pd | B367, Gr. C-8A |
| Zirconium | Zr | None | Zirconium | B752, Gr. 702C |

⁷ Alloys conform to the chemical and mechanical requirements of the latest edition of the ASTM specification.

© Duriron, Durichlor 51 and Superchlor are registered trademarks of Flowserve Corporation.

© Ferralium is a registered trademark of Langley Alloys.

© Hastelloy is a registered trademark of Haynes International, Inc.

© Inconel and Monel are registered trademarks of International Nickel Co. Inc.

Options to Solve Application Problems

Centerline Mounted Casing



Integral Jacketed Casing

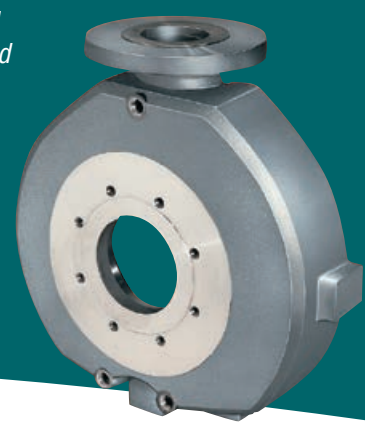

The Durco Mark 3 offers unique design technologies and component options with superior pump application, installation, process and selection knowledge. These extend pump performance and increase reliability. Certain applications need performance-enhancing options for continued reliability.

Centerline Mounted Casing

The Durco Mark 3 may be configured with a centerline mounted casing to reduce loads caused by thermal expansion. Optional jacketed feet with inlet and outlet ports further ensure effective temperature control.

Jacketed Casing

A jacketed casing is available with the Mark 3 to provide temperature control. Two designs are available: integral (shown) and bolt-on jackets.

Ultralign™ Heavy-Duty, Rigid Design C-Flange Adapter

- Cantilevered motor shaft stays aligned with pump shaft even with undesirable movement caused by piping and temperature-induced stress.
- Eliminates foot mounting of motor and pump power end to the base, reducing soft foot, twisting and diaphragming problems
- 0.18 mm (0.007 in) nominal parallel shaft alignment; 0.05 mm (0.002 in) with four point C-Plus precision alignment option
- <0.025 mm/mm (0.001 in/in) angular alignment
- The unique C-Plus Four Point Precision Alignment System enables installation and maintenance personnel to align shafts within 0.05 mm (0.002 in) in fewer than 30 minutes.
- Adjustable rigid foot mount is designed to support all normal loads and ensures accurate alignment to the baseplate and piping.



ClearGuard and DurcoShield Pump Safety Accessories



ClearGuard and DurcoShield Non-Metallic Safety Guards

ClearGuard and DurcoShield pump guards permit visual inspection of coupling and seal areas, respectively, while protecting personnel from potential safety hazards of rotating parts. Constructed of tough, durable and transparent polycarbonate with UV light inhibitors, they are designed to withstand tough chemical processing environments.

ClearGuard Non-metallic Coupling Guard

The ClearGuard Non-metallic Coupling Guard meets machinery guard safety guidelines. Nothing larger than 6 mm (0.24 in) in diameter can enter the shell. Furthermore, the ability to inspect the coupling through ClearGuard can provide early warning of deteriorating or malfunctioning components.

DurcoShield® Splash and Shaft Guard

The DurcoShield Splash and Shaft Guard is a one-piece shield that envelops the open areas between the bearing housing and casing. Suitable for applications to 150°C (300°F), DurcoShield protects users from:

- Process fluid spray
- Rotating shaft and seal components

Available Stilt-Mounted Baseplate

A stilt-mounted baseplate provides relief of external pipe loads by allowing the assembly to move to the point of least resistance.

- Standard stilts can allow for improved pump alignment to process pipe.
- Spring-loaded stilts absorb vibration and reduce the need for pipe loops or expansion joints.

⁸ DurcoShield is not a containment system or a seal backup system. It is a limited protection device. It will reduce, but not eliminate, the probability of injury.

**Durco Mark 3
Pre-Engineered
Baseplate Designs**



**Five Pre-Engineered Baseplate Designs
Extend Pump and Seal Life**

Flowserve offers five pre-engineered baseplate designs to improve pump performance while reducing costs. (See page 21).

Flowserve pre-engineered baseplates extend pump and seal life by reducing internal pump stress and vibrations. That is why Flowserve recommends using reinforced rigid baseplates.

Plus, pre-engineered and reinforced baseplates help avoid potential confusion in specification interpretation, delays in shipments and added costs.

Flowserve offers a broad range of metal and non-metallic, grout and stilt-mounted designs and standard options. This provides flexibility in choosing the baseplate that best meets application needs and operating budget.

| Item No. | Standard Options | Type A | | Type B | Type C | Type D | Type D w/Rim | Type E |
|----------|---|----------|------|--------|--------|--------|--------------|--------|
| | | Gp 1 & 2 | Gp 3 | | | | | |
| 1 | Machined coplanar mounting surfaces to 0.17 mm/m (0.002 in/ft) with 3.2 micron (125 µin) finish | O | O | O* | O | O | O | Y |
| 2 | Added structural (cross member) support | N | N | Y | Y | Y | Y | Y |
| 3 | Added torsional support with end caps | NR | Y | Y | D | O | O | Y |
| 3 | Added torsional support with end caps | NR | Y | Y | D | O | O | Y |
| 4 | Tapped holes for four (4) motor adjuster bolts | O | O | NA | O | O | O | Y |
| 5 | Four (4) — SS transverse jack bolts — motor adjusters | O | O | NA | O | O | O | Y |
| 6 | Sloped surface to an integral drain | N | N | C | N | N | N | Y |
| 7 | Integral sloped drip rim around base | N | N | N | N | N | Y | Y |
| 8 | 102 mm (4 in) diameter grout holes — max. 762 mm (30 in) run to vent | Y | Y | Y | N | Y | Y | Y |
| 10 | Lower surface shaped to anchor in grout | N | N | N | NA | Y | Y | Y |
| 11 | Integral lifting eyes at four (4) corners | O | Y | N | O | Y | Y | Y |
| 12 | Tapped leveling holes four (4) corners | Y | O | Y | S | Y | Y | Y |
| 13 | Continuous seam weld construction | NA | Y | NA | O | Y | Y | Y |
| 14 | Welded raised lip around grout hole(s) | NR | NR | NA | NA | NR | NR | Y |
| 15 | Stilt-mounting options with floor cups | NR | NA | O | Y | D | D | NA |
| 16 | Spring-mounted load designs | NA | NA | O | O | D | D | NA |
| 17 | Catch basin (304 SS or other materials) | O | O | NA | O | O | NR | NA |
| 18 | Option for eight (8) total motor adjusters | O | O | O | O | O | O | Y |
| 19 | Dimensions to ASME B73.1 | Y | Y | Y | Y | Y | Y | Y |

Y = Standard
O = Optional

N = Not available
NA = Not applicable

NR = Not recommended
C = Sloped catch basin with 25 mm (1 in) drain (option)

D = Needs design time
S = Stilts for leveling

See page 21 for model descriptions.

*Coplanar to 0.42 mm/m (0.005 in/ft)

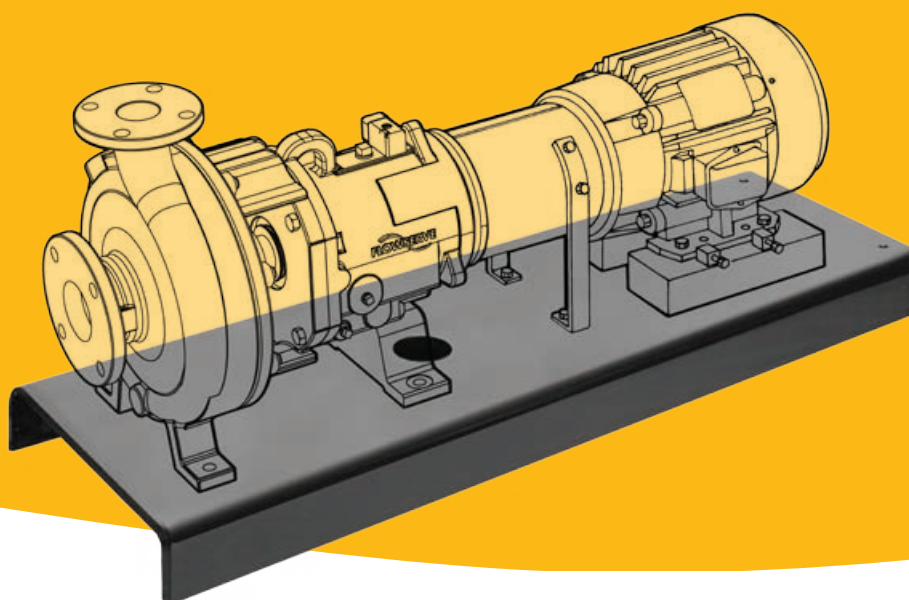

Type A

Standard ASME (ANSI) baseplate;
foundation mounted

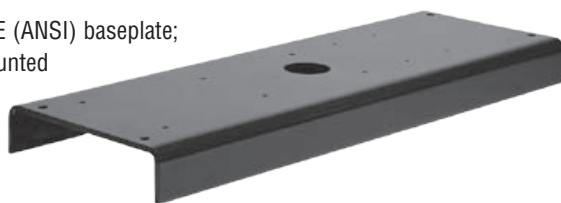

Type B

Polybase™; foundation or
stilt mounted



Type C

Reinforced; stilt
mounted



Type D

Reinforced; foundation
mounted; drip
rim optional



Type E

Heavy-duty, foundation
mounted; complies
with PIP
RESP 002

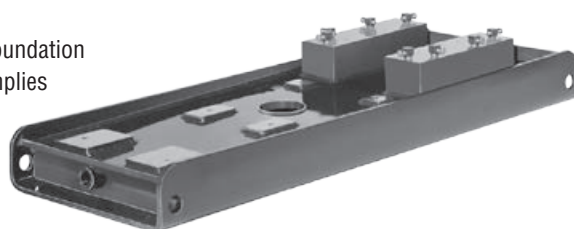

Rigid Design Extends Pump Life and Lowers Costs

FlowsERVE offers a family of five types of pre-engineered baseplate designs to extend pump life and reduce costs. Each is designed to:

- Provide torsional lateral and longitudinal rigidity
- Improve vibration dampening
- Protect against transit damage
- Resist twisting during installation
- Maintain shaft alignment
- Reduce installation and shaft alignment time
- Reduce diaphragming or separation from grout
- Improve pump, motor and seal reliability
- Reduce total life cycle pump, motor and seal costs

Rigid, Thick Plate Construction

Metal baseplate sizes:

- 139 to 258 feature 12 mm (1/2 in) steel plate
- 264 to 280 feature 16 mm (5/8 in) steel plate
- 368 to 398 feature 19 mm (3/4 in) steel plate

Polybase baseplates are constructed of 76 mm (3 in) to 102 mm (4 in) solid polymer concrete.

Types B, C, D and E are reinforced with added structural support for improved rigidity.

Polybase™ Solid Polymer Concrete Baseplate

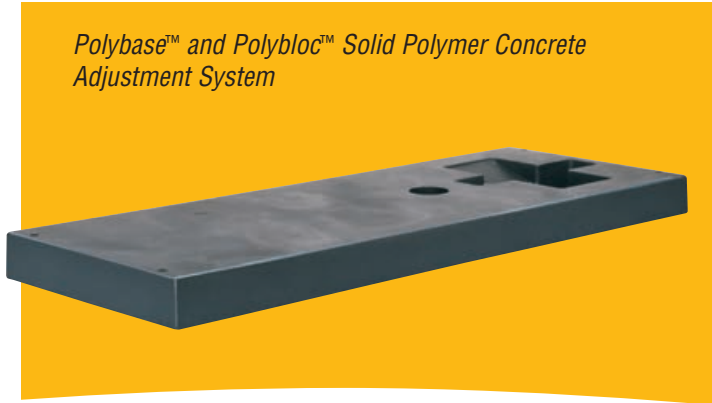

Polybase™ and Polybloc™ Solid Polymer Concrete Adjustment System

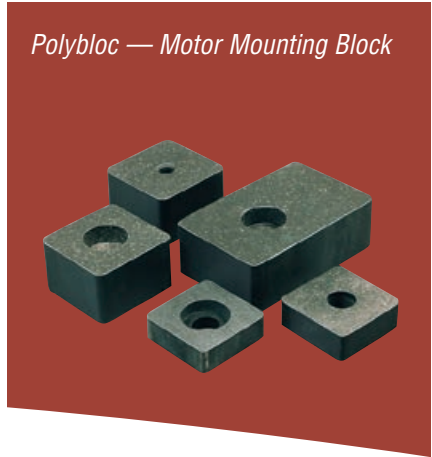

Polybloc — Motor Mounting Block

This Polymer Concrete Baseplate System Offers Impressive Benefits:

- Low installed cost
- Superior vibration damping
- Corrosion resistance
- Superior resistance to twisting or diaphragming
- Optional catch basin and grout holes
- Inserts available for alternate equipment configuration requirements

Baseplates Are Fundamental to Extending Pump Life

The test stand provides three-corner support of the ungrouted baseplates. The addition of weights on the unsupported fourth corner caused baseplate distortion. This distortion resulted in measurable shaft movement that can cause problems with field installations and negatively affect pump reliability and life.

The twist test is a means of comparing rigid baseplate designs. Correctly installed rigid baseplates should not experience these twist effects. For more information about the results of baseplate testing, contact your local Flowserve sales representative.

Vibration Damping of Polymer Concrete Versus Cast Iron

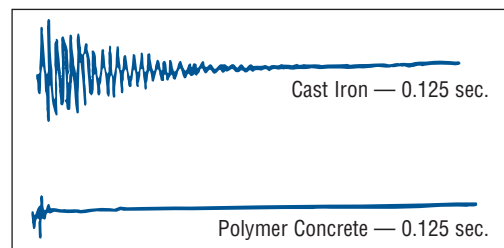

© John F. Kane, Composites Institute, The Society of the Plastics Industry, Inc.

Baseplate Rigidity Test — Twist Mode

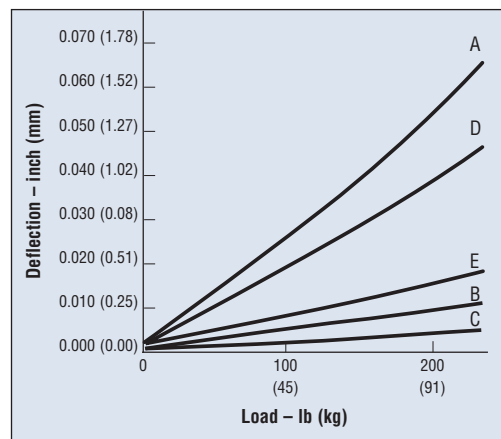

Maximum Parallel Shaft Deflection at Applied Force

| | |
|--------|--------------------|
| Type A | 0.022 in (0.56 mm) |
| Type B | 0.004 in (0.10 mm) |
| Type C | 0.003 in (0.08 mm) |
| Type D | 0.016 in (0.41 mm) |
| Type E | 0.005 in (0.13 mm) |

**Flowserve Polyshield
Polymer Baseplate and
Foundation System**



Cost-Effective, High-Performance Baseplate and Foundation System

The Polyshield baseplate and foundation system is the superior solution for cost-effective, high-performance pump installation. In one complete unit, it combines a traditional baseplate with a formed concrete foundation for pump-drive sets.

Benefits of Selecting the Polyshield Baseplate and Foundation System

- Time savings
 - Quick installation time
 - Reduces time span from receipt at job site to commissioning
- Cost savings
 - Reduces total installed cost
 - Dramatically minimizes field rework necessary to meet specifications
- Better performance and reliability
 - Extended pump life
 - Reduced vibration
 - Improved corrosion resistance
- Single structure convenience
 - One-piece construction
 - Flat mounting surfaces
 - One-piece motor mounting block

Broad Application

The Polyshield baseplate and foundation system can be combined with numerous pump designs, including:

- ISO and ASME (ANSI) metallic and non-metallic
- Foot and frame mounted general industrial
- Foot mounted between bearings
- ISO 13709/API 610

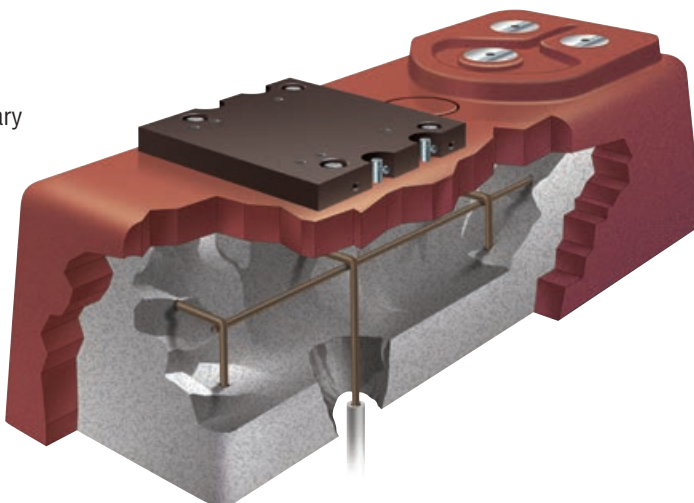

Durco Mark 3 Lo-Flo™ Pump

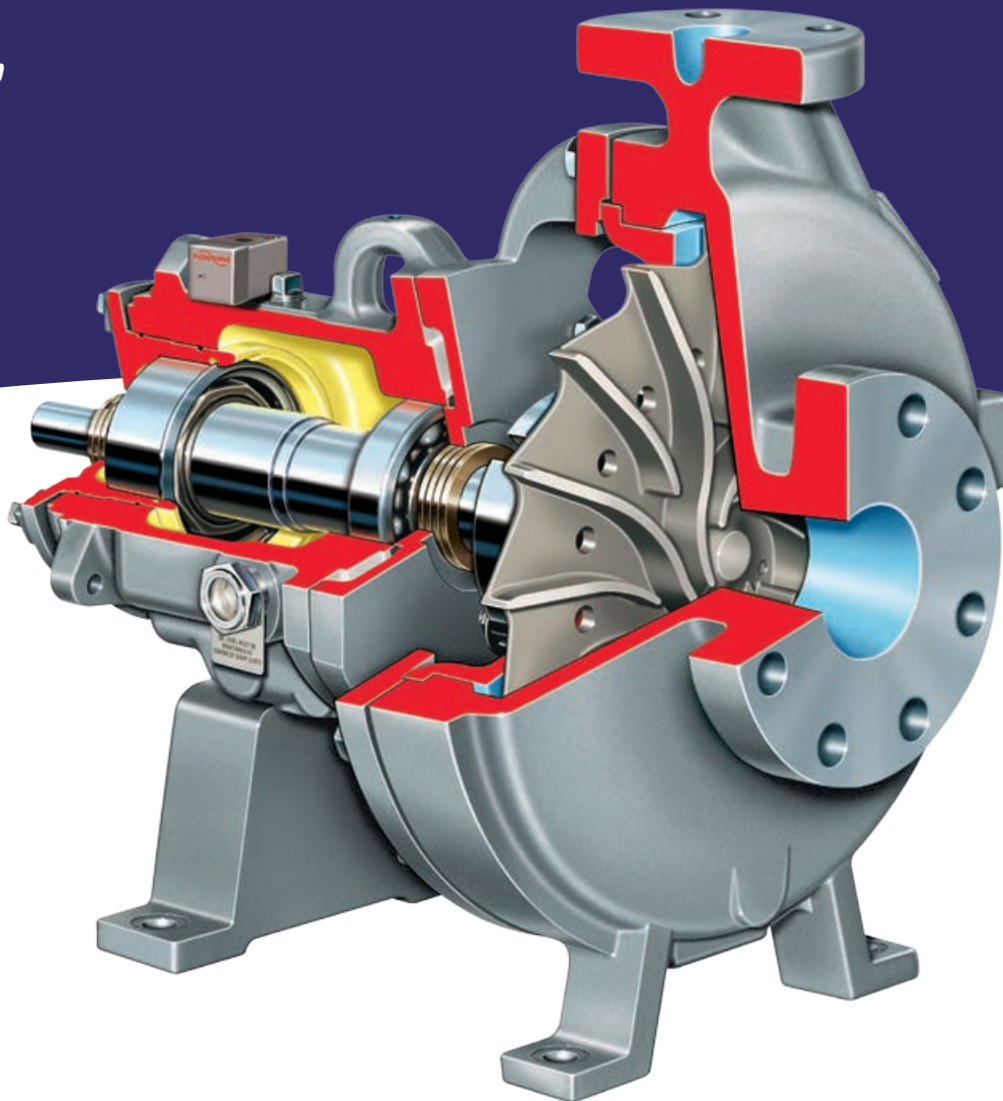

Conforming to ASME (ANSI) B73.1, the Durco Mark 3 Lo-Flo pump is designed to improve pump reliability and performance in low-flow, high-head applications. The first pump manufacturer to introduce an ASME (ANSI) standard low-flow, high-head pump, Flowserve developed its innovative radial vane impeller and circular, concentric casing to reduce radial loads and shaft vibration while extending bearing and mechanical seal life.

Operating Parameters

- Flows to 50 m³/h (220 gpm)
- Heads to 300 m (985 ft)
- Pressures to 31 bar (450 psi)
- Temperatures from -75°C (-100°F) to 370°C (700°F)

Features and Benefits

Radial Vane Impeller provides improved performance over a broader application range.

Circular Concentric Casing reduces radial loads and vibration and extends bearing and seal life.

SealSentry™ Seal Chambers extend seal life and provide advanced self-flushing capability.

External Micrometer Impeller Adjustment accurately sets impeller clearance in 20 seconds, in the shop or in the field.

Back Pull-out Design allows removal of rotating element without removing casing, piping or motor.

Heavy-duty Pump End and Drive End Bearings are selected for long life and reliability.

Typical Applications

- Acid transfer
- Chemical and petrochemical processing
- Food and beverage processing
- Pharmaceuticals
- Polymers
- Pulp and paper
- Seawater
- Slurries
- Solvents
- Steel and primary metals
- Water and wastewater treatment



Innovative Radial Vane Impeller Design

The Durco Mark 3 Lo-Flo pump features an innovative radial vane impeller which has a unique twist to provide superior performance in low-flow, high-head conditions.

Efficient Circular Concentric Casing

The circular concentric casing of the Durco Mark 3 Lo-Flo pump is more hydraulically efficient at lower flow rates than conventional volute casings. The key to the casing's efficiency is an internal bypass — drilled in the discharge without breaching the casing wall or creating a potential leak path — which helps to balance pressures.

Reduced Vibration

Shaft vibration is a critical factor in both bearing and mechanical seal life. Reducing shaft vibration results in significantly improved pump performance and reliability.

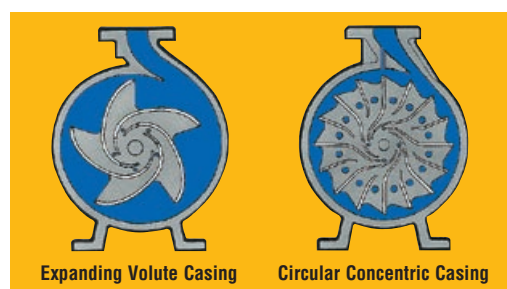

Improved Performance and Reliability

The radial vane impeller and circular, concentric casing of the Mark 3 Lo-Flo pump improve pump performance and reliability when compared to standard pumps. Maintenance is also reduced.

- Reduced radial loads up to 90% at low flows
- Minimized thrust loads
- Reduced NPSH requirements
- Reduced shaft vibration
- Extended bearing and mechanical seal life
- Broadened application range

Choice of Power Ends

- Standard Mark 3A power end with double lip oil seals and top vent/breather
- ANSI 3A power end (shown on page 8) featuring Inpro VBXX bearing isolators and a lifetime warranty

Four Sizes Available

- 1K1.5x1LF-4
- 1K1.5x1LF-8
- 2K2x1LF-10
- 2K3x1.5LF-13

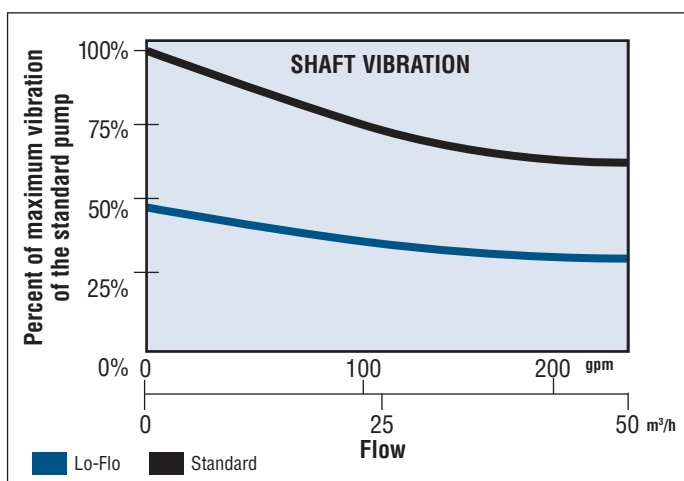

Durco Mark 3 Sealmatic Pump

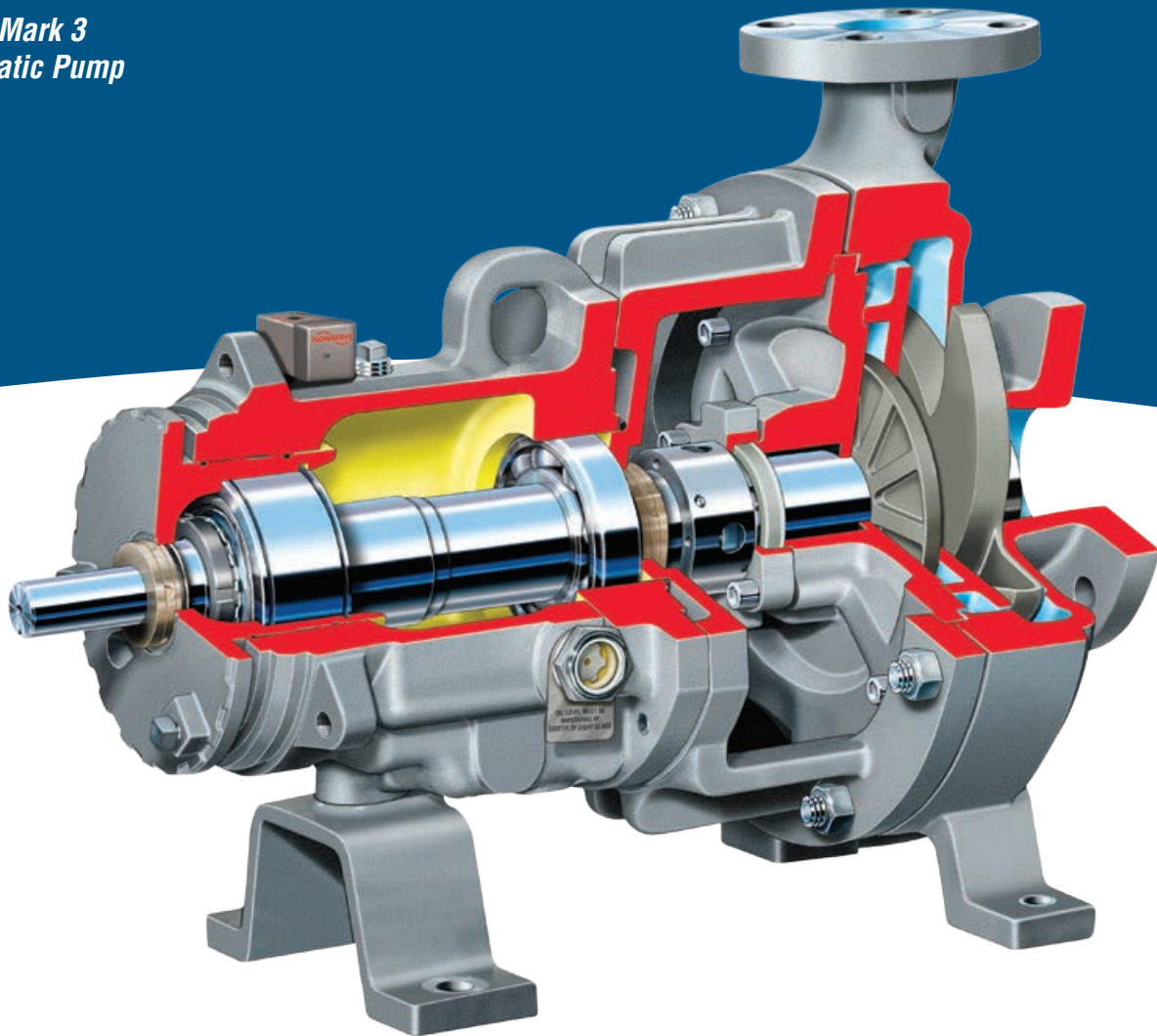

With the Durco Mark 3 Sealmatic pump, no mechanical seal is needed during operation. A dynamically sealing repeller (expeller) expels fluid from the seal chamber, making it ideal for hard-to-seal applications. Furthermore, the needs for external flushing and process contamination control are eliminated.

The Sealmatic pump conforms to ASME (ANSI) B73.1.

Operating Parameters

- Flows to 1680 m³/h (7400 gpm)
- Heads to 230 m (755 ft)
- Pressures to 31 bar (450 psi)
- Temperatures from -75°C (-100°F) to 370°C (700°F)

Eighteen Sizes Available

- 12 Group 2
- Six Group 3

Features and Benefits

Spinning Expeller creates centrifugal force to expel fluid from the seal chamber.

Standard Reverse Vane Impeller is the only impeller design that offers repeatable performance throughout the life of the pump. Open impeller is available.

External Micrometer Impeller Adjustment accurately sets impeller clearance in 20 seconds, in the shop or in the field.

Back Pull-out Design allows removal of rotating element without removing casing, piping or motor.

Heavy-duty Pump End and Drive End Bearings are selected for long life and reliability.

Typical Applications

- Hard-to-seal liquids (e.g., sodium hydroxide, mineral acids, phosphoric acid, sulfuric acid)
- Applications in which seal flush is undesirable (e.g., evaporator feed service, ethanol production)
- Continuous-duty applications (e.g., recirculation in starch conversion)
- Liquids containing solids
- Batch operations where run-dry conditions might exist (e.g., tank unloading)

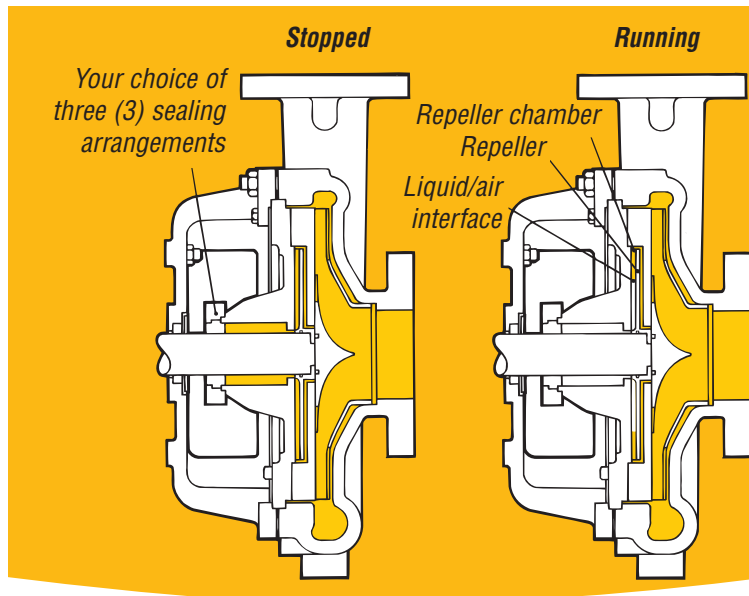

Dynamically Sealing Repeller

The Durco Mark 3 Sealmatic pump is equipped with a dynamically sealing repeller. This technology enables users to significantly reduce the total life cycle cost of process pumps in demanding applications by:

- Eliminating the need for conventional mechanical seals and their associated maintenance costs
- Eliminating the need for an external flush and the associated product dilution
- Eliminating the need for contamination control

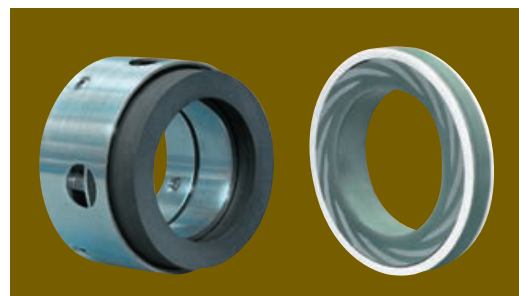

Operating Principle

The key to the Sealmatic's dynamic sealing technology is centrifugal force.

As liquid is drawn into the eye of the impeller, the centrifugal force created by the rapidly rotating repeller expels liquid from the seal chamber. In so doing, the pressure of the liquid in the pump and atmospheric pressure are equalized, creating a liquid/air interface and prohibiting shaft leakage.

Choice of Static Sealing Options

For positive sealing while the pump is stopped, Flowserve offers a choice of low-cost alternatives to mechanical seals, including:

- Self-lubricating, flexible graphite packing
- The FXP stationary fluoropolymer disk seal
- Dry-running, end-face seal
- Elastomeric lip seals

These static sealing options have the additional benefit of not requiring external flush.

Additional Configurations

The Sealmatic design also is available in recessed impeller and in-line configurations.

Durco Mark 3 Unitized Self-Priming Pump

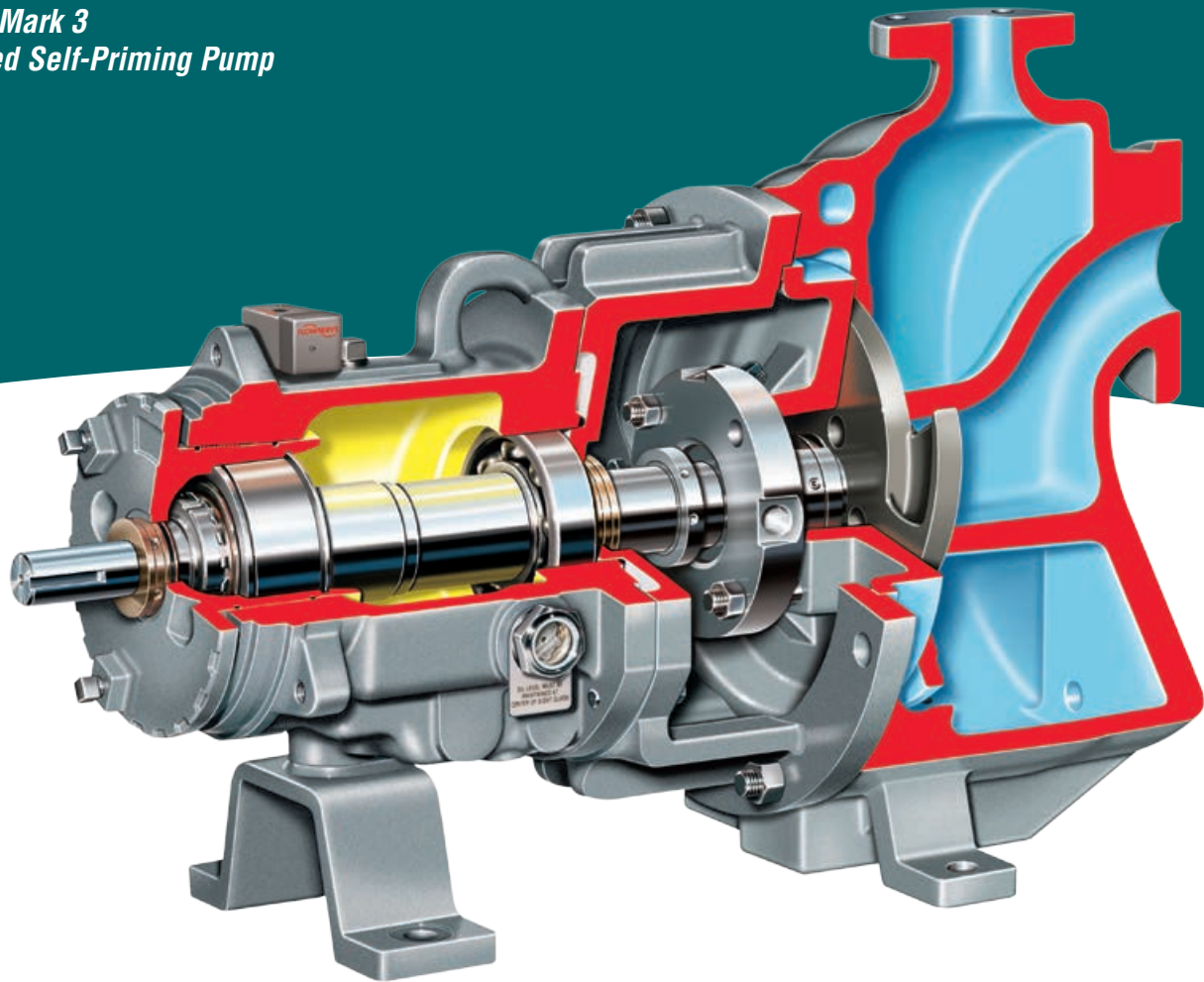

The Durco Mark 3 Unitized Self-Priming pump is engineered to draw from liquid sources below ground level or from sources which have no positive pressure to naturally prime the pump. Conveniently located high and dry at ground level where installation is simple and maintenance is easily and more economically performed, the Mark 3 Self-Priming pump costs less to buy, install and maintain than submersible pumps.

The Mark 3 Self-Priming pump's compact design enables it to fit in tight clearance locations. It also can be mounted on a trailer for movement to various pumping areas, such as for wastewater lagoon service.

Operating Parameters

- Flows to 320 m³/h (1400 gpm)
- Heads to 120 m (400 ft)
- Pressures to 20 bar (285 psi)
- Temperatures to 370°C (700°F)
- Static suction lift to 6 m (20 ft)

Features and Benefits

Unitized Casing has large priming chamber, air separator and volute in one integral component. This design eliminates the need for a separate priming tank.

Standard Reverse Vane Impeller is the only impeller design that offers repeatable pump performance throughout the life of the pump. Open impellers are available.

External Micrometer Impeller Adjustment accurately sets impeller clearance in 20 seconds, in the shop or in the field.

SealSentry Seal Chambers extend seal life and provide advanced self-flushing capability.

Back Pull-out Design allows removal of rotating element without removing casing, piping or motor.

Heavy-duty Pump End and Drive End Bearings are selected for long life and reliability.

Typical Applications

- Sump service
- Tank car unloading
- Duplex pumping lift station
- Fly ash pond transfer
- Waste acid transfer
- Waste treatment lagoon service

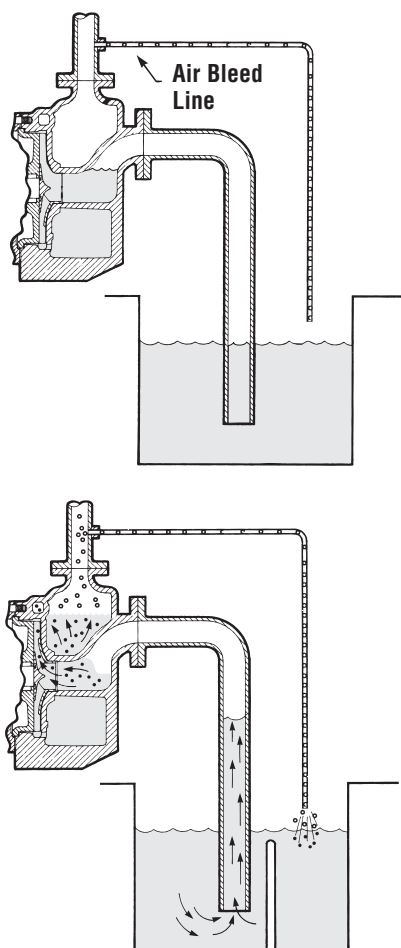
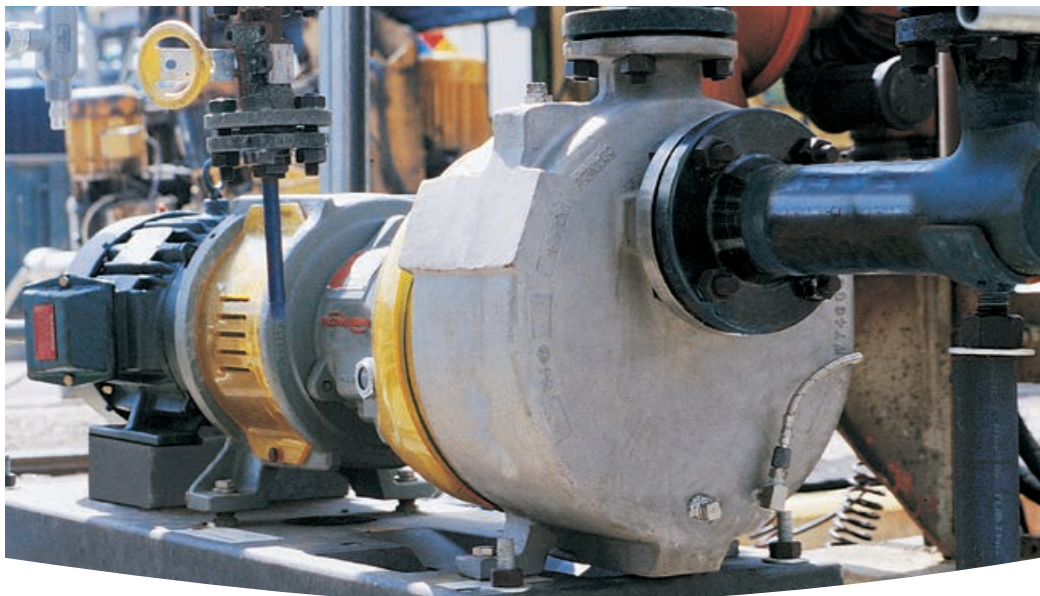

The Priming Principle

The Durco Mark 3 Unitized Self-Priming pump uses liquid recirculation to prime the pump. The pressure differential between the aerated liquid at the impeller and the non-aerated liquid in the priming chamber creates a vacuum that pulls liquid up the pipe. As a result, the Durco Mark 3 Unitized Self-Priming pump is ideal for suction lift applications or for pumping liquids with air or gas phases.

Benefits of the Mark 3 Unitized Self-Priming Pump

- Eliminates internal valves
- Eliminates external priming devices or foot-valves
- Portable
- Compact
- Ease of installation
- Ease of maintenance

Choice of Power Ends

- Standard Mark 3A power end with double lip oil seals and top vent/breather
- ANSI 3A power end (shown on page 8) featuring Inpro VBXX bearing isolators and a lifetime warranty

Eleven Sizes Available

- Three Group 1
- Eight Group 2

Durco Mark 3 Recessed Impeller Pump

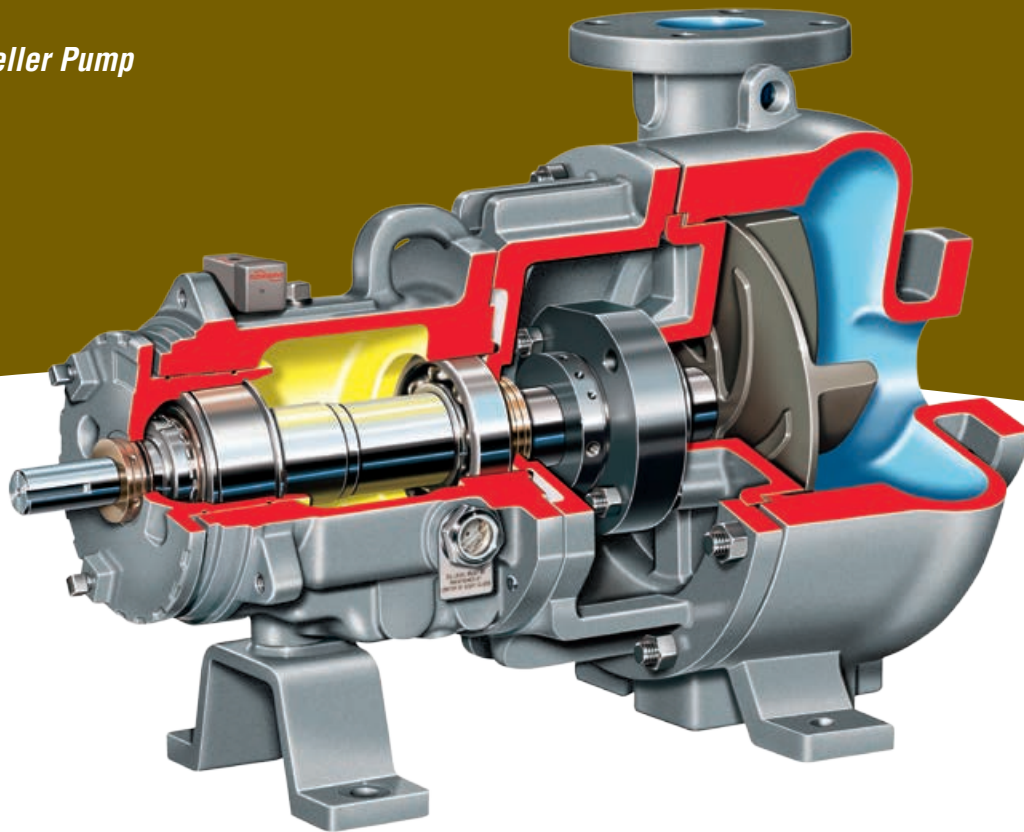

The Durco Mark 3 Recessed Impeller pump combines the best design features of the Mark 3 ASME (ANSI) Standard pump with the vortex action of a recessed impeller. These specific purpose features along with thick wall wet-end components offer extended service life when handling solid, stringy or fibrous slurries.

The Durco Mark 3 Recessed Impeller pump boasts a wide clearance at the front of the open impeller, allowing passage of larger particles. Solids are drawn into the low-shear vortex of swirling liquid and discharged by centrifugal force through the open area in front of the impeller with little contact, minimizing particle degradation. Furthermore, the air and gas-handling capability of the pump is improved.

Operating Parameters

- Flows to 455 m³/h (2000 gpm)
- Heads to 120 m (400 ft)
- Pressures to 20 bar (285 psi)
- Temperatures from -75°C (-100°F) to 370°C (770°F)

Five Sizes Available

- One Group 1
- Four Group 2

Features and Benefits

Recessed Impeller Design creates a vortex which expels solids from critical areas to maximize seal or packing life.

Vortex Action minimizes abrasive wear while maintaining solids integrity because only a fraction of the media contacts the impeller.

Standard CD4MCuN Duplex Stainless Steel Construction provides outstanding wear and abrasion resistance. Also available in all standard Mark 3 alloys.

Cylindrical Volute Casing With Tangential Discharge minimizes turbulence, improving pump performance and decreasing abrasion.

External Micrometer Impeller Adjustment accurately sets impeller clearance in 20 seconds, in the shop or in the field.

SealSentry Seal Chambers extend seal life and provide advanced self-flushing capability.

Back Pull-out Design allows removal of rotating element without removing casing, piping or motor.

Heavy-duty Pump End and Drive End Bearings are selected for long life and reliability.

Typical Applications

- Light slurries
- Corrosive or erosive services
- Large diameter solids
- Waste streams
- Fluids with which shearing must be avoided
- Protection of solids integrity



Vortex Pumping Action

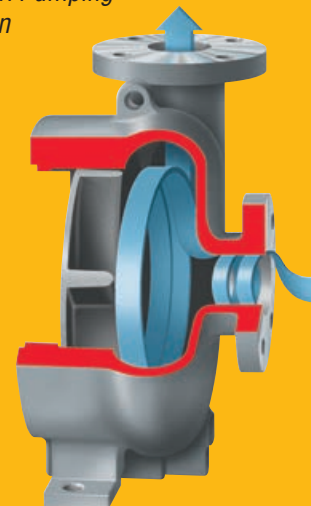

High-Efficiency Open Impeller

The Durco Mark 3 Recessed Impeller pump comes standard with a precision cast open impeller that ensures peak energy efficiency and low NPSHR. The design incorporates pump-out vanes that prolong mechanical seal or packing life by:

- Ensuring low, positive seal chamber pressure
- Expelling solids from critical seal
- Providing axial hydraulic balance

Cylindrical Volute Casing

Cylindrical volute casing of the Durco Mark 3 Recessed Impeller pump minimizes radial loads on the impeller. The result is longer seal life as well as maximized radial bearing life.



Benefits of Vortex Pumping Action

The vortex created by the spinning impeller does the pumping with less than 20% of media contacting the impeller. Abrasive wear is minimized and solids integrity is maintained.

- Improved solids handling
- Improved air and gas handling
- Improved ability to pass fibrous or stringy substances
- Reduced wear
- Low NPSHR

Choice of Power Ends

- Standard Mark 3A power end with double lip oil seals and top vent/breather
- ANSI 3A power end (shown on page 8) featuring Inpro VBXX bearing isolators and a lifetime warranty

Additional Configurations

The Mark 3 Recessed Impeller pump can be specified with the Sealmatic dynamically sealing repeller and as self-priming with priming tank option. For applications requiring vertical installations, the ESP3 sump pump also offers a recessed impeller configuration.

**Complementary
Pumps**



Durco Mark 3 In-Line

Designed to exceed ASME (ANSI) B73.2 criteria, the Durco Mark 3 In-Line process pump incorporates many of the same advanced design features as other Mark 3 models, such as reverse vane impeller, SealSentry seal chambers and external micrometer impeller adjustment. In addition, this space-saving pump has its own independent bearing housing and rigid style motor adapter.

Please refer to bulletin PS-10-15 for additional product information.

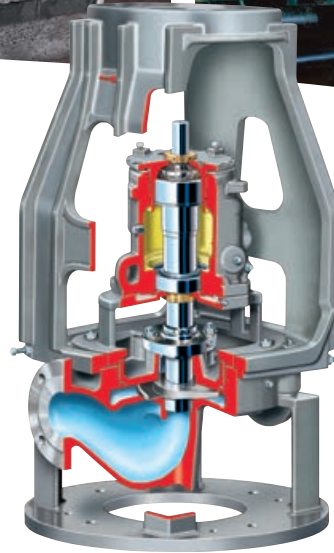

Durco Mark 3 Group 4

Designed to complement the Durco Mark 3 pump, the Mark 3 Group 4 delivers flow rates well beyond traditional ASME (ANSI) pump sizes. Outside the scope of the ASME (ANSI) performance and dimensional requirements, the Group 4 is designed for maximum reliability and efficiency in demanding applications.

Please refer to bulletin PSS-10-13.2 for additional product information.

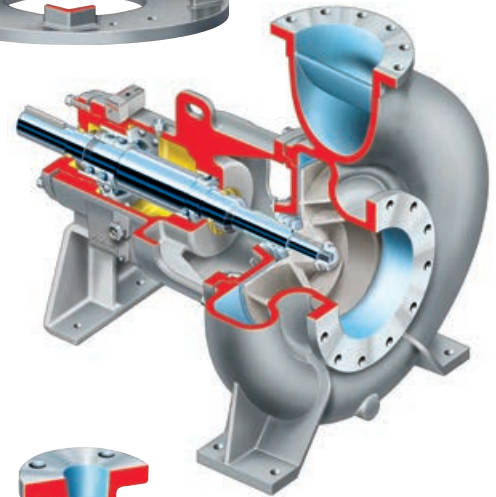

Guardian ASME (ANSI) Magnetic Drive Pump

The Guardian magnetic drive pumps meet ASME (ANSI) B73.1 dimensional standards and are available in 18 sizes. Offered in a wide range of corrosion-resistant materials, the Guardian magnetic drive pump is ideal for high temperature, leak-free applications.

Please refer to bulletin PS-10-14 for additional product information.

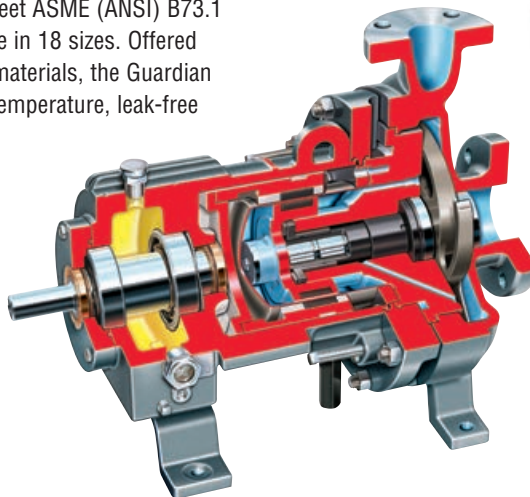

Complementary Pumps



Mark 3 ISO Standard

Durco Mark 3 ISO Chemical Process Pumps

Conforming to ISO 2858 and ISO 5199 design criteria, the Durco Mark 3 ISO chemical process pump incorporates many of the same reliability- and performance-enhancing features as the Durco Mark 3 ASME (ANSI) pump. Its reverse vane impeller, SealSentry seal chambers and optional ISO 3A power end provide outstanding hydraulic efficiency, unrivaled dependability and low total cost of ownership.

Durco Mark 3 ISO chemical process pumps are available in many designs and configurations to meet the needs of the process industries:

- Reverse vane or open impeller
- Recessed impeller
- Unitized self priming
- Close coupled

Please refer to bulletin PS-10-31 for additional product information.

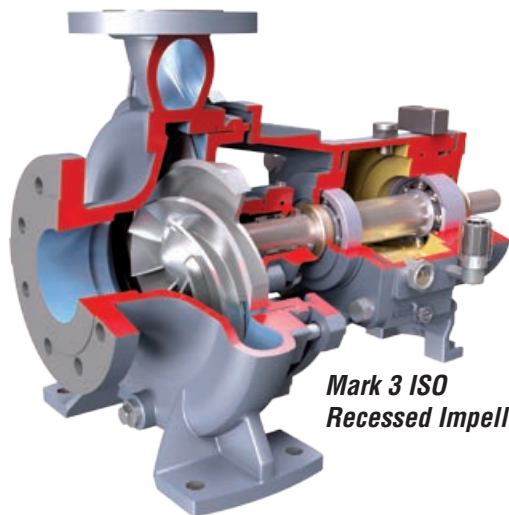

Mark 3 ISO Recessed Impeller

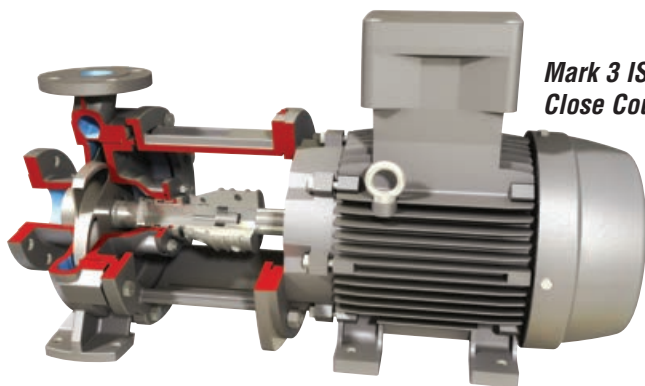

Mark 3 ISO Close Coupled

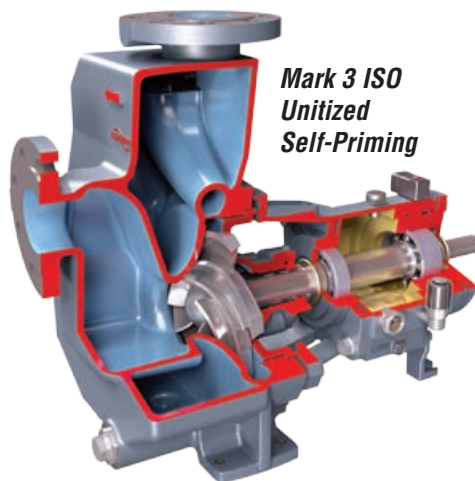

Mark 3 ISO Unitized Self-Priming

Complementary Pumps

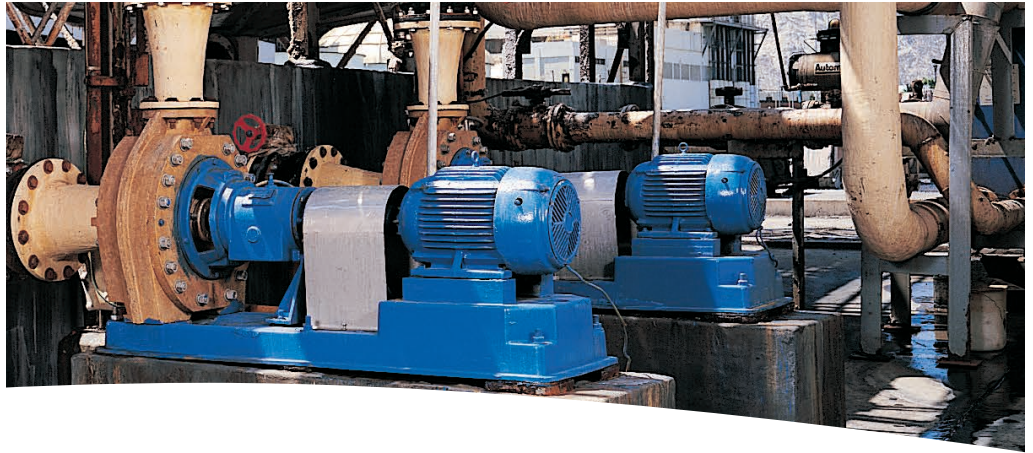

PolyChem™ Non-Metallic Chemical Process Pumps

Embracing a global approach to pump design, Flowserve offers sealed and sealless PolyChem non-metallic pumps engineered to ASME (ANSI) and ISO design criteria and to JIS drilling specifications. The fluoropolymer-lined S-Series pump and the GRP engineered polymer composite pump are well suited for highly corrosive applications in the worldwide process industries.

- PolyChem S-Series: fluoropolymer lined, mechanically sealed
- PolyChem GRP: engineered composite

Please refer to bulletin PS-10-17 for additional product information.

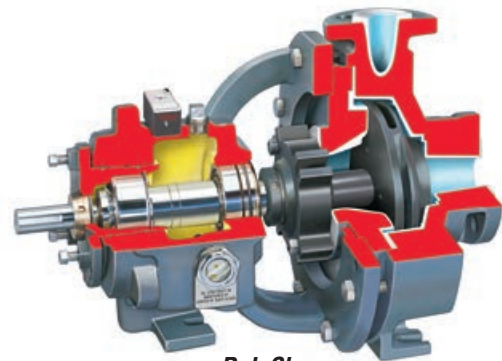

PolyChem S-Series

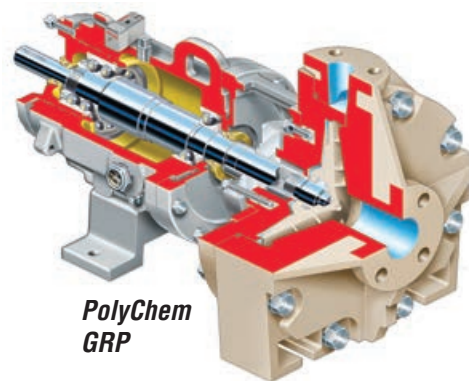

PolyChem GRP

INNOMAG TB-MAG™ Fluoropolymer-lined Magnetic Drive Pump

Compliant with ASME B73.3 or ISO 2858 dimensional standards, this versatile pump provides low total cost of ownership and exceptional leakage protection in extremely corrosive and environmentally critical applications. Its revolutionary dynamic thrust balancing system eliminates the need for thrust bearings and results in highly efficient operation with outstanding reliability, even in applications containing solids.

Please refer to bulletin PS-10-36 for additional product information.

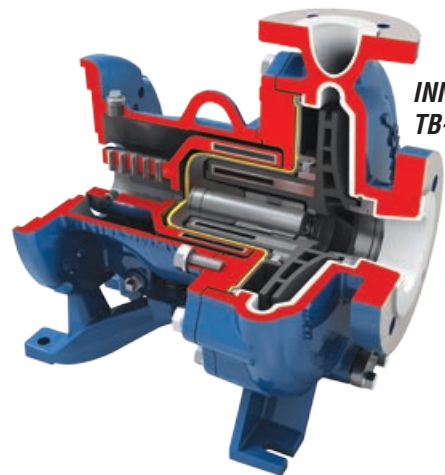

INNOMAG TB-MAG

**Global Service
and Technical
Support**



Life Cycle Cost Solutions

Typically, 90% of the total life cycle cost (LCC) of a pumping system is accumulated after the equipment is purchased and installed. Flowserve has developed a comprehensive suite of solutions aimed at providing customers with unprecedented value and cost savings throughout the life span of the pumping system. These solutions account for every facet of life cycle cost, including:

Capital Expenses

- Initial purchase
- Installation

Operating Expenses

- Energy consumption
- Maintenance
- Production losses
- Environmental
- Inventory
- Operating
- Removal

Innovative Life Cycle Cost Solutions

- New Pump Selection
- Turnkey Engineering and Field Service
- Energy Management
- Pump Availability
- Proactive Maintenance
- Inventory Management

Typical Pump Life Cycle Costs¹

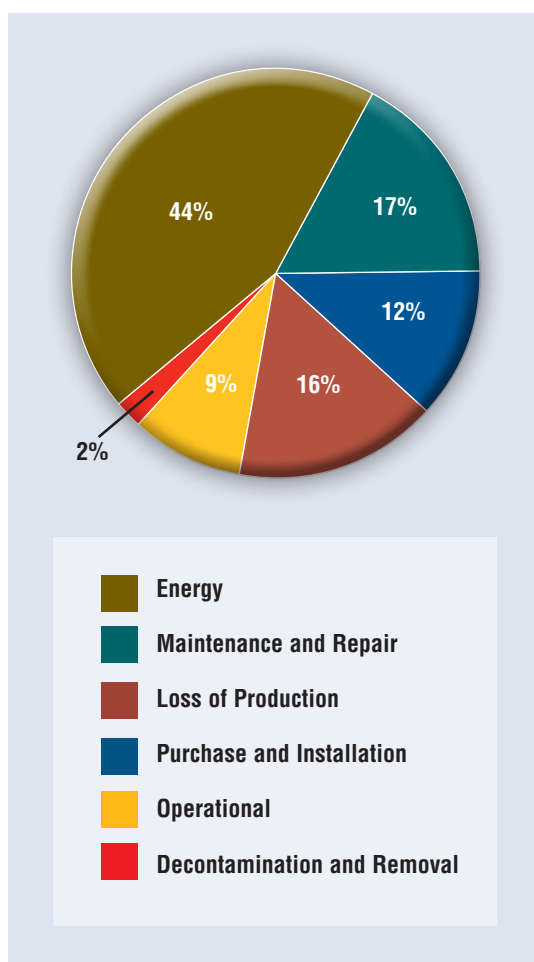

¹ While exact values may differ, these percentages are consistent with those published by leading pump manufacturers and end users, as well as industry associations and government agencies worldwide.



USA and Canada

Flowserve Corporation
5215 North O'Connor Blvd.
Suite 2300
Irving, Texas 75039-5421 USA
Telephone: +1 937 890 5839

Europe, Middle East, Africa

Flowserve Corporation
Parallelweg 13
4878 AH Etten-Leur
The Netherlands
Telephone: +31 76 502 8100

Latin America

Flowserve Corporation
Martín Rodríguez 4460
B1644CGN-Victoria-San Fernando
Buenos Aires, Argentina
Telephone: +54 11 4006 8700
Telefax: +54 11 4714 1610

Asia Pacific

Flowserve Pte. Ltd.
10 Tuas Loop
Singapore 637345
Telephone: +65 6771 0600
Telefax: +65 6862 2329

Bulletin PS-10-13n (E/A4) October 2015. © 2015 Flowserve Corporation

To find your local Flowserve representative:

For more information about Flowserve Corporation,
visit www.flowserve.com or call +1 937 890 5839.