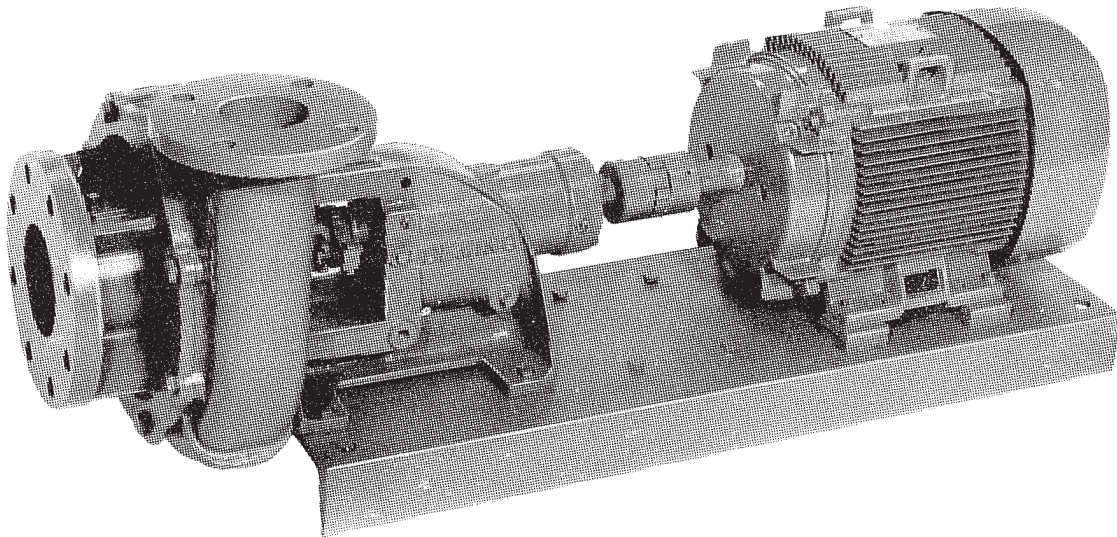


# DEMING<sup>®</sup>

INSTALLATION, OPERATION & MAINTENANCE MANUAL  
End-suction Centrifugal Pumps

Series: 4001, 4011  
4021, 4021H



**IMPORTANT!**

***Read all instructions in this manual before operating pump.  
As a result of Crane Pumps & Systems, Inc., constant product improvement program,  
product changes may occur. As such Crane Pumps & Systems reserves the right to  
change product without prior written notification.***

**CRANE**<sup>®</sup>

A Crane Co. Company

**PUMPS & SYSTEMS**

420 Third Street  
Piqua, Ohio 45356  
Phone: (937) 778-8947  
Fax: (937) 773-7157  
[www.cranepumps.com](http://www.cranepumps.com)

83 West Drive, Bramton  
Ontario, Canada L6T 2J6  
Phone: (905) 457-6223  
Fax: (905) 457-2650

Form No. 119999-Rev. F

# SAFETY FIRST!

Please Read This Before Installing Or Operating Pump. This information is provided for **SAFETY** and to **PREVENT EQUIPMENT PROBLEMS**. To help recognize this information, observe the following symbols:



**IMPORTANT!** Warns about hazards that can result in personal injury or indicates factors concerned with assembly, installation, operation, or maintenance which could result in damage to the machine or equipment if ignored.

**CAUTION!** Warns about hazards that **can or will cause minor** personal injury or property damage if ignored. Used with symbols below.

**WARNING!** Warns about hazards that can or will cause serious personal injury, death, or major property damage if ignored. Used with symbols below.



*Hazardous fluids can cause fire or explosions, burns or death could result.*



*Extremely hot - Severe burns can occur on contact.*



*Biohazard can cause serious personal injury.*



*Hazardous fluids can Hazardous pressure, eruptions or explosions could cause personal injury or property damage.*

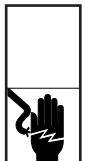


*Rotating machinery Amputation or severe laceration can result.*



*Hazardous voltage can shock, burn or cause death.*

Only qualified personnel should install, operate and repair pump. Any wiring of pumps should be performed by a qualified electrician.



**WARNING!** To reduce risk of electrical shock, pumps and control panels must be properly grounded in accordance with the National Electric Code (NEC) or the Canadian Electrical Code (CEC) and all applicable state, province, local codes and ordinances. Improper grounding voids warranty.



**WARNING!** To reduce risk of electrical shock, always disconnect the pump from the power source before handling or servicing. Lock out power and tag.



**WARNING!** Operation against a closed discharge valve will cause premature bearing and seal failure on any pump, and on end suction and self priming pump the heat build may cause the generation of steam with resulting dangerous pressures. It is recommended that a high case temperature switch or pressure relief valve be installed on the pump body.



**CAUTION!** Pumps build up heat and pressure during operation-allow time for pumps to cool before handling or servicing.



**WARNING!** Do not pump hazardous materials (flammable, caustic, etc.) unless the pump is specifically designed and designated to handle them.



**WARNING!** Do not wear loose clothing that may become entangled in moving parts.



**WARNING!** Keep clear of suction and discharge openings. **DO NOT** insert fingers in pump with power connected.



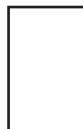
Always wear eye protection when working on pumps.



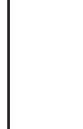
Make sure lifting handles are securely fastened each time before lifting. **DO NOT** operate pump without safety devices in place. Always replace safety devices that have been removed during service or repair. Secure the pump in its operating position so it can not tip over, fall or slide.



**DO NOT** exceed manufacturers recommendation for maximum performance, as this could cause the motor to overheat.



**WARNING!** To reduce risk of electrical shock, all wiring and junction connections should be made per the NEC and CEC and applicable state or province and local codes. Requirements may vary depending on usage and location.



**WARNING!** Products returned must be cleaned, sanitized, or decontaminated as necessary prior to shipment, to insure that employees will not be exposed to health hazards in handling said material. All Applicable Laws And Regulations Shall Apply.



Bronze/brass and bronze/brass fitted pumps may contain lead levels higher than considered safe for potable water systems. Lead is known to cause cancer and birth defects or other reproductive harm. Various government agencies have determined that leaded copper alloys should not be used in potable water applications. For non-leaded copper alloy materials of construction, please contact factory.

Crane Pumps & Systems, Inc. is not responsible for losses, injury, or death resulting from a failure to observe these safety precautions, misuse or abuse of pumps or equipment.

# CONTENTS

SAFETY FIRST .....	2
A. GENERAL INFORMATION.....	3
Receiving, Storage, Service Centers	
B. BEFORE TOU BEGIN .....	3
C. INSTALLATION.....	4 - 5
D. LUBRICATION.....	5
E. PROPER ADJUSTMENT OF IMPELLER.....	5
F. PROPER ADJUSTMENT OF STUFFING BOX..	6
G. GENERAL REPAIRS .....	6
H. FOR INSPECTION & REPAIR OF LIQUID END..	6
I. TO INSPECT/REPLACE BEARINGS.....	6 - 7
J. REASSEMBLING OF SHAFT & BEARINGS.....	7
K. REASSEMBLY OF LIQUID END .....	7
L. REPACKING STANDARD STUFFING BOX.....	7
M. TO REPLACE SINGLE MECHANICAL SEAL ...	7 - 8
N. TO REPLACE DOUBLE MECH. SEAL.....	8
O. LOCATING TROUBLE.....	9
CROSS-SECTIONS & PARTS LIST.....	10
WARRANTY & RETURNED GOODS.....	11

## A - GENERAL INFORMATION TO THE PURCHASER:

Congratulations! You are the owner of one of the finest pumps on the market today. These pumps are products engineered and manufactured of high quality components. With years of pump building experience along with a continuing quality assurance program combine to produce a pump which will stand up to the toughest applications. Check local codes and requirements before installation. Servicing should be performed by knowledgeable pump service contractors or authorized service stations.

### RECEIVING:

Upon receiving the pump, it should be inspected for damage or shortages. If damage has occurred, file a claim immediately with the company that delivered the pump. If the manual is removed from the crating, do not lose or misplace.

### STORAGE:

**Short Term** - Pumps are manufactured for efficient performance following long inoperative periods in storage. For best results, pumps can be retained in storage, as factory assembled, in a dry atmosphere with constant temperatures for up to six (6) months.

**Long Term** - Any length of time exceeding six (6) months, but not more than twenty four (24) months. The units should be stored in a temperature controlled area, a roofed over walled enclosure that provides protection from the elements (rain, snow, wind blown dust, etc.), and whose temperature can be maintained between +40 deg. F and +120 deg. F.

Pump should be stored in its original shipping container and before initial start up, rotate impeller by hand to assure seal and impeller rotate freely.

### SERVICE CENTERS:

For the location of the nearest Deming Service Center, check your Deming representative or Crane Pumps & Systems Service Department in Piqua, Ohio, telephone (937) 778-8947 or Crane Pumps & Systems Canada, Inc., Bramton, Ontario, (905) 457-6223.

## B - BEFORE YOU BEGIN

Motor driven pumps are carefully aligned on sub-base before shipment. However, after they are placed upon the foundation and sub-base is bolted down, the alignment must be rechecked and in MOST CASES it will be found necessary to carefully realign the unit. Quite often a noisy pump is due to pump and motor not being properly aligned. **IN SUCH CASES WE DISCLAIM ALL RESPONSIBILITY FOR PROPER WORKING OF PUMP.**

Pumps are normally furnished with standard stuffing box construction as shown on page 5. Mechanical shaft seal can be furnished in lieu of standard stuffing box.

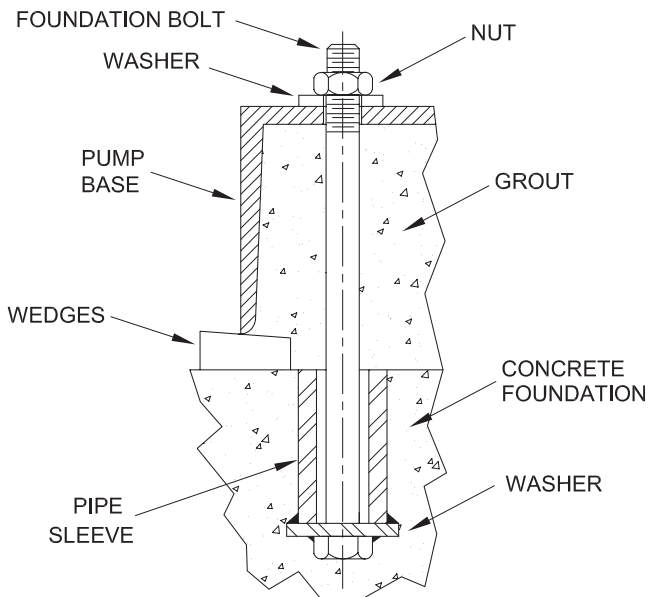
The single shaft seal on page 5 is used for handling clear liquids at temperatures below their boiling point or 212°F (100°C) as recommended by the seal manufacturer. A portion of this liquid is by-passed into the seal chamber through the by-pass tube (127) to serve as a lubricant and as a coolant. The by-pass from the pump discharge must be minimum of 20 pounds pressure above the suction pressure of the pump to insure proper operation of the seal.

The double shaft seal on page 6 is used when pumping abrasive or non-lubricating liquids or liquids of excessive temperature. If the discharge pressure ever exceeds 25 pounds, a sealing liquid at 15 to 20 pounds higher than maximum discharge pressure must be circulated through the seal chamber. Clear water under such pressure can be used in most applications as a sealing liquid for lubrication and cooling.

If the discharge pressure is constantly under 25 pounds and the temperature is less than the boiling point of the liquid being pumped or 212°F (100°C), then seal chamber can be filled with a quality light weight ball bearing grease. A spring-loaded compression type grease cup should be installed to maintain pressure in the seal chamber.

## C - INSTALLATION

1. A good rigid foundation must be provided for pump base.
2. Place pumping unit on foundation with bolts, of the proper size, imbedded in the concrete. A pipe sleeve, about 2½" diameters larger than the bolt, should be used to allow for final positioning of the bolts. See Figure 1.



**Figure 1. Foundation Bolt Location and Anchorage**

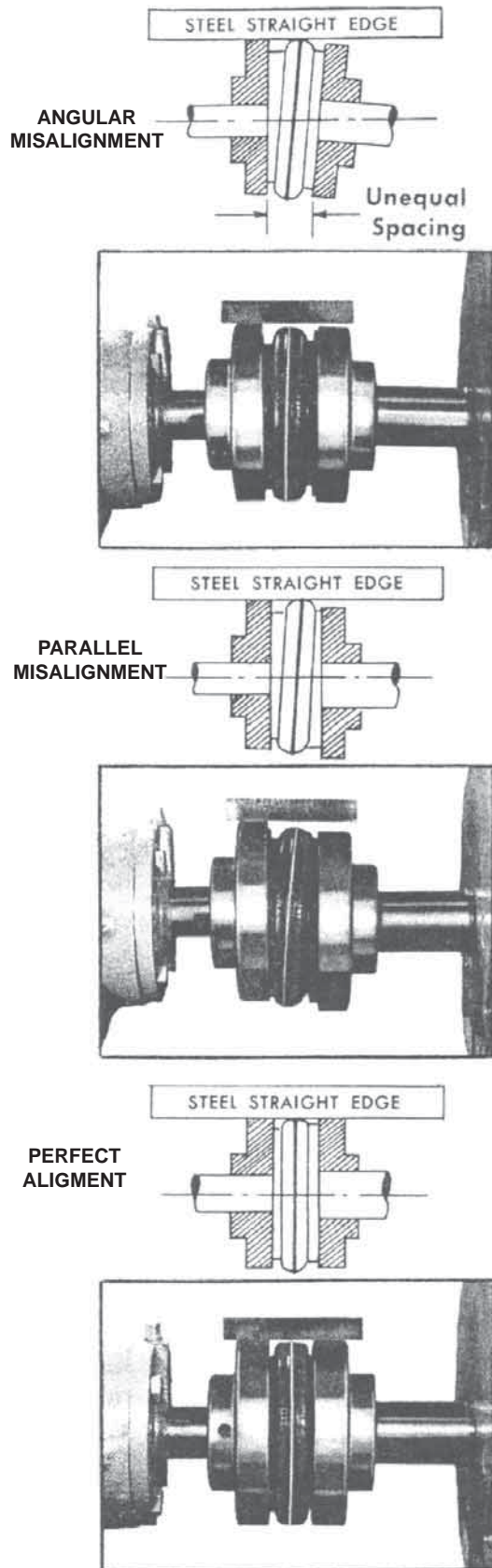
Level sub-base, to give a space of about 3/4" for grouting, using rectangular metal blocks and shims, or wedges having a small taper as shown.

3. Align the pump and motor shafts at the flexible coupling. Hold a straight edge on the top of the coupling so that it extends over both halves. Straight edge should rest evenly across both rims of the coupling halves when the straight edge is placed on the top, sides and bottom with no light showing between the straight edge and rim of the coupling. Also check vertical alignment of the coupling faces with a thickness gauge. Faces must be parallel and spaced about 1/8" apart when the motor rotor is at its extreme position towards the pump. This safe guards the pump shaft being crowded endwise by the motor shaft end play. By proper adjustment of metal shims under pump or motor, both halves of the flexible coupling can be brought into alignment See Figure 2.



**WARNING! - Coupling Guards must be used to avoid serious injury to operating personnel.**

4. Build a dam around sub-base at least 2" high for grouting in with thin cement and after cement has hardened, tighten anchor bolts.



**Figure 2**

5. Recheck alignment at drive coupling. Any misalignment now apparent should be corrected by metal shims under pump or motor. When properly aligned, pump shaft should turn freely by hand.
6. A foot valve and strainer must be installed on the lower end of the suction pipe to keep pump completely filled with liquid when the pump is used under suction lift conditions. Connect suction pipe to pump casing.

When a foot valve is used, it is **absolutely necessary to install a check valve** in the discharge line near the pump to prevent possible broken casing due to line shock or surge when the pump stops. A gate valve should also be installed in the discharge line. Connect discharge pipe to pump casing.

It is very important that the suction and discharge pipes "line up" naturally with the pump. DO NOT "pull" pipes into position with flange bolts. Support pipes independently of the pump to eliminate all strain on the pump casing. Select discharge pipe size so velocity is under 8 feet per second. Avoid sharp changes in pipe sizes.

7. After pipes have been connected to pump, check alignment at drive coupling. Correct any changes with metal shims as in section "C".
8. Check motor nameplate for electrical characteristics. Be sure they are the same as the rating of the electrical power available. Connect power lines to motor in accord with wiring diagram on the motor and test motor rotation, should turn in the direction indicated by arrow cast on pump casing.
9. Fill pump (and suction pipe) with water. Remove plug (352) at top of casing (1) to relieve trapped air, then replace plug. Close discharge gate valve and start pump. When pump is up to speed, slowly open the discharge valve to obtain desired capacity and pressure.

#### D - LUBRICATION

1. Pump bearings are properly filled with grease at the factory before shipment. Periods of subsequent lubrication depend somewhat on local conditions, loads, speed, hours of operation, temperature, etc. Periodic inspection of bearing lubrication should be made and additional grease added as needed thru grease cups (207) on the pump. A No. 2 grease (soft) is recommended for most installations. Do Not over grease as this causes high bearing temperatures and shortens bearing life.
2. Motor bearings should also have periodic attention and lubrication in accord with motor manufacturers recommendations. Under ordinary conditions a ball bearing will run from 10° to 60°F (-12.2° to 15.6°C) above surrounding temperatures. Unless bearing temperature runs extremely hot do not become alarmed.

3. On standard-fitted, bronze-fitted and all-bronze construction, the stuffing box is lubricated by liquid being pumped, thru a by-pass tube. On all-iron construction, the by-pass tube is eliminated and a grease cup installed for stuffing box lubrication. A "water pump" grease is recommended for the grease cup. If the liquid being pumped is abrasive, a fresh water supply should be connected to the stuffing box instead of the grease fitting (243) or tubing (127).

4. Single seals normally do not require grease lubrication as they are lubricated and cooled by the liquid returned to the seal chamber thru the by-pass tube.
5. Double seals should be cooled and lubricated by a sealing liquid under pressure, such as clear water. If the pressure at the inner face of the seal is constantly under 25 psi and the liquid temperature is under the boiling point, or 212°F (100°C), a spring-loaded compression type grease cup, filled with Standard Artic No. "O" grease or equal, may be used if suitable sealing liquid is not available.

#### GENERAL MAINTENANCE AND REPAIR

##### E - PROPER ADJUSTMENT OF IMPELLER

1. Loosen adjusting nut clip (66) by unscrewing cap screw (337) then turn bearing adjusting nut (204) counter-clockwise to allow the impeller (2) to just touch the frame (19). It may be necessary to bump the shaft (6) on coupling end to make sure the bearing (16) is against the bearing adjusting nut (204). Then back off the impeller slightly by tightening the bearing adjusting nut in a clockwise direction. Rotate the shaft by hand to make certain that the impeller does not rub against the suction head face. Lock the bearing adjusting nut in place with the bearing adjusting nut clip (66) and cap screw (337).
2. One of the outstanding features of this pump is the impeller axial adjustment for wear or capacity. Less water, head, or horsepower, may be achieved by turning the bearing adjusting nut (204) in a clockwise direction. This moves the impeller away from the suction head face. If maximum head or capacity are required, move the impeller as close as possible to the suction head face without allowing it to rub.

An extremely accurate adjustment may be made by adjusting the impeller while in operation and checking the motor with a watt-meter. After final adjustment of impeller is made, lock the bearing adjusting nut in place with adjusting nut clip and tighten cap screw. This adjustment should not be changed until the impeller face is worn enough to warrant readjustment.

## F - PROPER ADJUSTMENT OF STUFFING BOX

1. The liquid being pumped should constantly, yet slowly drip from the stuffing box gland (17) when the pump is running. This slow drip keeps the shaft from becoming scored. NEVER tighten the gland so as to entirely stop leakage through stuffing box. It increases the power and wears the shaft in a short time.
2. The split gland (17) can be taken apart. This facilitates repacking the stuffing box. Access to the packing (13) is obtained by removing the nuts from bolts (209) which fasten the stuffing box gland to the stuffing box head. Clean out the drip holes in the gland occasionally as they may become clogged, especially with new packing. The drip hole allows the sealing liquid to drip thru the gland, instead of passing between the gland and the shaft.
3. Standard pumps are equipped with a circulation tube (127) from discharge to the stuffing box lantern ring so that the pump will not suck air in along the shaft when the pump is operating on a suction lift. If the pump is to operate with positive suction head, disconnect this tube, plug the holes concerned and run the pump with the stuffing box gland as loose as possible to avoid excessive shaft wear through the stuffing box.

## G - GENERAL REPAIRS



***If pumping any fluid that could cause bodily injury (Hot water, caustic, etc.), Always use eye protection and wear protective clothing over all exposed body areas.***

Whenever it is necessary to dismantle the pump for repairs, it should be removed from the sub-base. Disconnect the suction and discharge pipes and remove the four cap screws holding pump to sub-base. Drain pump by removing drain plug (216) in the bottom of the pump casing (1).

### CLEAN AND INSPECT ALL PARTS

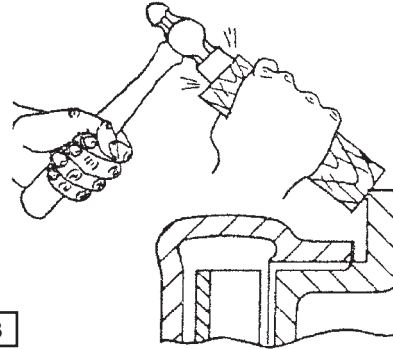
Extreme care should be exercised in keeping the parts clean. Special precautions should be taken to keep ball bearings dirt-free while in or out of the pump. The dirt will damage the ball bearings, thus shortening the trouble-free service life of the pump.

Any part which is excessively worn or deteriorated should be replaced with new parts from factory.

When ordering repairs refer to the illustrations for part names and the pump name plate on which is stamped the figure number, size and serial number. Without this information we cannot identify the pump and parts in question.

## H - FOR INSPECTION AND REPAIR OF LIQUID END

1. Remove suction head cap screws (215), then set a block of wood against the finished flange or back of the frame (19) and tap block lightly with a hammer to loosen suction head. Remove suction head from pump and place casing gasket (73) in a bucket of water to keep it soft and pliable.



**Figure 3**

2. Bend and remove cotter pin (269) in castellated nut (24).
3. Unscrew the castellated nut (24) by turning counter-clockwise while holding shaft (6) with a wrench at drive coupling. Then slide impeller washer (270) off the shaft.
4. To remove the impeller (2) from the shaft, make three special cap screws as follows:  
Fig. 4001 - 3/8" x 16 NC with thread cut 1 3/4" long;  
Fig. 4011 and 4021 - 1/2" x 13NC with thread cut 2" long.  
Screw these cap screws into the three tapped holes in the impeller shroud. The cap screws will tighten against the stuffing box head (11) thus forcing the impeller from the shaft. Lift key (32) from its seat in the shaft .
5. To remove the pump casing (1), first disconnect by-pass tube (127) from the casing then remove casing cap screws (215), casing and stuffing box gasket (241) will lift off the frame (19). Place gasket in water.
6. The stuffing box head (11) can be removed after loosening gland bolts (209) and nuts (210).

## I - TO INSPECT OR REPLACE BALL BEARINGS ON SHAFT

1. Dismantle liquid end of pump as described in section "H" then loosen set screws in pump half of drive coupling and remove coupling from pump shaft. Also remove key (46) from shaft.
2. Unscrew bearing cover cap screws (213) remove bearing cover (37) and gasket (303) and bearing adjusting spring (347). Place gasket in water. Pull the pump shaft (6) out thru the coupling end of the frame (19). Slinger (40) will drop into support head drip basin. Be careful not to lose it.

3. By inspection, determine whether it is necessary to replace the ball bearings (16) & (18). If so, press on inner race of the shielded side of the bearing and not against the outer race of the bearing or the shaft shoulder.

#### J - REASSEMBLING OF SHAFT AND BEARINGS

1. To replace bearings slide bearing (18) over the coupling end of the shaft (shielded side first) until the inner race is tight against the shaft shoulder. Then slide bearing (16) onto the tapered end of the shaft, shielded side first, Apply fresh grease, of the proper grade, between the races of each bearing. Also fill bearing housing in the support head about 1/4 full of grease. **Never use any of the old grease.**
2. Inspect felt ring (40) in the bearing cover (37) and in the bearing adjusting nut (204). To replace felt rings remove clamping rings (257) and insert new felt rings. Press clamping rings into position.
3. Insert shaft (6) into support head from coupling end, tapered end first. When shaft starts thru bearing adjusting nut (204), place slinger (40) over the end of the shaft. Push shaft thru support head until bearing (18) is tight against adjusting nut. Place bearing adjusting spring (347) over coupling end of shaft and place bearing cover gasket (303) on bearing cover. Slide bearing cover over end of shaft and push against end of support head compressing bearing adjusting spring sufficiently to replace bearing cover cap screws (213). Tighten cap screws securely. Place shaft key (46) in keyway on end of pump shaft and press pump half of drive coupling onto shaft. Tighten set screws.

#### K - REASSEMBLY OF LIQUID END

1. If stuffing box head (11) was removed, place stuffing box head over shaft in manner shown with slots for bolts and nuts on the horizontal centerline. The holes in the flange of the stuffing box head should be in line with those in the frame (19).
2. Insert casing cap screws (215) thru holes in support head and stuffing box head and position gasket (73) on the stuffing box head. Place casing (1) on the support head with discharge in the desired position. Tighten casing cap screws securely. Connect by-pass tubing (127) to casing.
3. Seat impeller key (32) in shaft keyway and place impeller (2) on shaft with keyway over impeller key. Place a wooden block over impeller vanes and tap on wood to seat impeller on the shaft taper. Replace impeller washer (270) on the shaft and then the castellated nut (24). Tighten nut securely. **DO NOT USE IMPELLER NUT TO DRAW IMPELLER ONTO SHAFT, NUT IS A LOCKING DEVICE ONLY.**

4. Replace cotter pin (269) in castellated nut.
5. Position suction head gasket (73) on frame (19) and replace suction head on the casing. Fasten in place with cap screws (215).
6. Replace gland bolts (209) and nuts (210) and tighten "finger tight". Check impeller adjustment per Section E and replace bearing adjusting nut clip (66) and screw (337). See Section F for proper stuffing box adjustment.

#### L - REPACKING STANDARD STUFFING BOX

1. Remove stuffing box bolts (209) and nuts (210) also gland bolts and nuts and remove gland from shaft. With a packing puller, remove the old stuffing box packing (13) and lantern ring (29) from the stuffing box (17).
2. Make sure that the correct packing is used for liquid being pumped.
3. Cut five rings of packing so that when wrapped around the shaft, the ends just touch.
4. Tamp first ring into stuffing box, then turn shaft over by hand.
5. Stagger the next packing ring joint so that the joint will be 180° apart. Seat ring evenly and tamp into place. Turn shaft again by hand.
6. Place lantern ring (29) in next.
7. Position and seat the next three rings of packing separately, staggering the joints 180° apart. Tamp into place.
8. Replace stuffing box gland, (17) fastening the two halves together with gland bolts and nuts. Replace and tighten stuffing box bolts and nuts (209) and (210), then loosen nuts until shaft can be turned freely by hand. See section "F" for proper adjustment.

#### M - TO REPLACE SINGLE MECHANICAL SEAL Refer to Figure 4.

**NOTE:** Seals are available as a complete assembly only.

1. Special precautions must be observed when handling a mechanical seal. **DO NOT** drop seal face carbons, or floating seats, nor scratch the lapped faces of these parts.
2. To remove the seal assembly, dismantle the liquid end of the pump as described in Section "H". After removing the casing, the seal head assembly may be removed from the support head. Press the seat gasket (B) and floating seat (C) from the seal head (52).
3. To install new seal assembly, oil the outer surface of the seat gasket (B) and press seat gasket and floating seat assembly (B) and (C) into the seal head cavity. **DO NOT SCRATCH FACE OF FLOATING SEAT.**

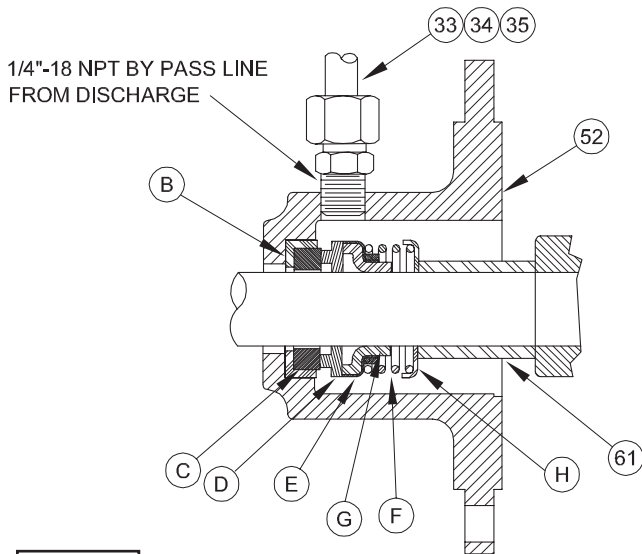
## N - TO REPLACE DOUBLE MECHANICAL SEAL

Refer to Figures 5 & 6.

**NOTE:** Seals are available as a complete assembly only.

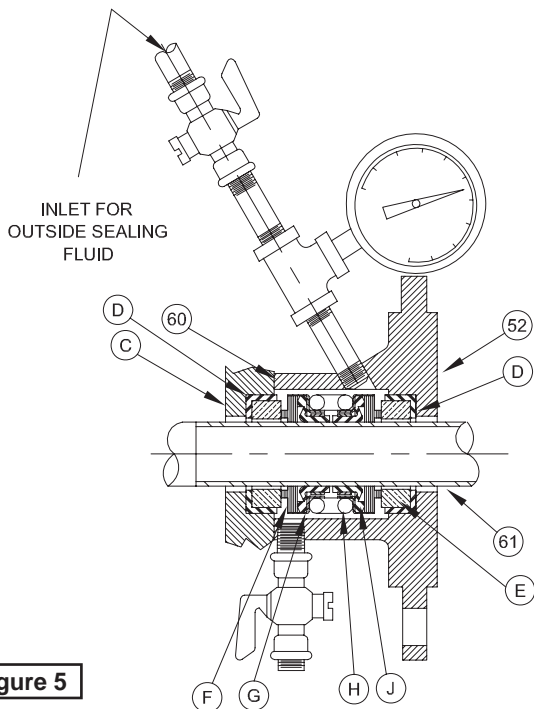
1. Special precautions must be observed when handling a mechanical seal. **DO NOT** drop the seal face carbons or floating seats nor scratch the lapped faces for these pieces.

52	Seal Head	F	Seal Face Carbon
60	Seal Gasket	G	Retainer
C	Seal Gland	H	Spring
D	Seat Gasket	J	Bellows
E	Floating Seat		

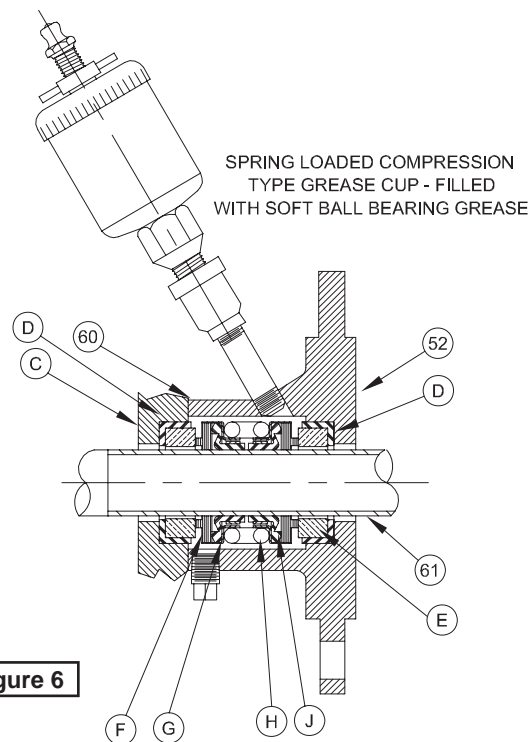


**Figure 4**

4. Apply a thin coating of clean light oil (not grease) to the shaft and reposition seal head (52) on the support head. Also apply a thin coating of light oil to the inside of the seal bellows, slide the seal face carbon (D), bellows (G), retainer (E), spring (F), spring holder (H) and spacer (61) onto the shaft. **NOTE:** It may be necessary to use a piece of tubing, slightly larger than the shaft, to push the bellows and retainer onto the shaft. Apply pressure only on the "tail section" of the bellows and retainer.
5. Insert casing cap screws (215) through holes in support head and seal head and position gasket (73) on seal head. Complete assembly of liquid end as described in Section "K".



**Figure 5**



**Figure 6**

2. To remove the seal assembly, dismantle the liquid end of the pump as described in Section "H", then unscrew gland bolts (209) and nuts (210). Remove seal head casting (52) from the support head, exposing the seal assembly. Grasp the seal firmly by hand and twist it on the shaft to break the seal between the bellows and the shaft. The seal can now be pulled from the shaft. Also remove the seal gland (56) from the shaft. Place gland gasket (60) in water. Press seat gaskets (D) and floating seat (E) from the seal gland (56) and seal head (52).
3. To install new seal assembly, oil the outer surface of seat gasket (D) and press seat gasket and floating seat assembly (D) and (E) into the seal gland cavity. Also apply oil to the outer surface of seat gasket and press seat gasket and floating seat assembly into the cavity in the base of the seal head (52). **DO NOT SCRATCH**



### FACE OF FLOATING SEATS.

4. Apply a thin coating of light oil (not grease) to the shaft and inside of bellows then slide the seal gland assembly (56) onto the shaft, followed by the gland gasket (60), then the seal face carbon (F), with retainer (G) and bellows (J). It may be necessary to use a piece of tubing, slightly larger than the shaft, to push the bellows and retainer onto the shaft. Apply pressure only on the "tail section" of the bellows and retainer. Next, place the spring (H) over the first section of the seal already on the shaft, then slide the second bellows, retainer and seal face carbon onto the shaft.
5. Next, place the seal head (49) over the shaft with slots for bolts (209) and nuts (210) on the horizontal centerline. The holes in the flange of the seal head should be in line with those of the support head. Insert casing cap screws (215) through holes in the support head and seal head and position gasket (73) on seal head. Complete assembly of liquid end as described in Section "K".

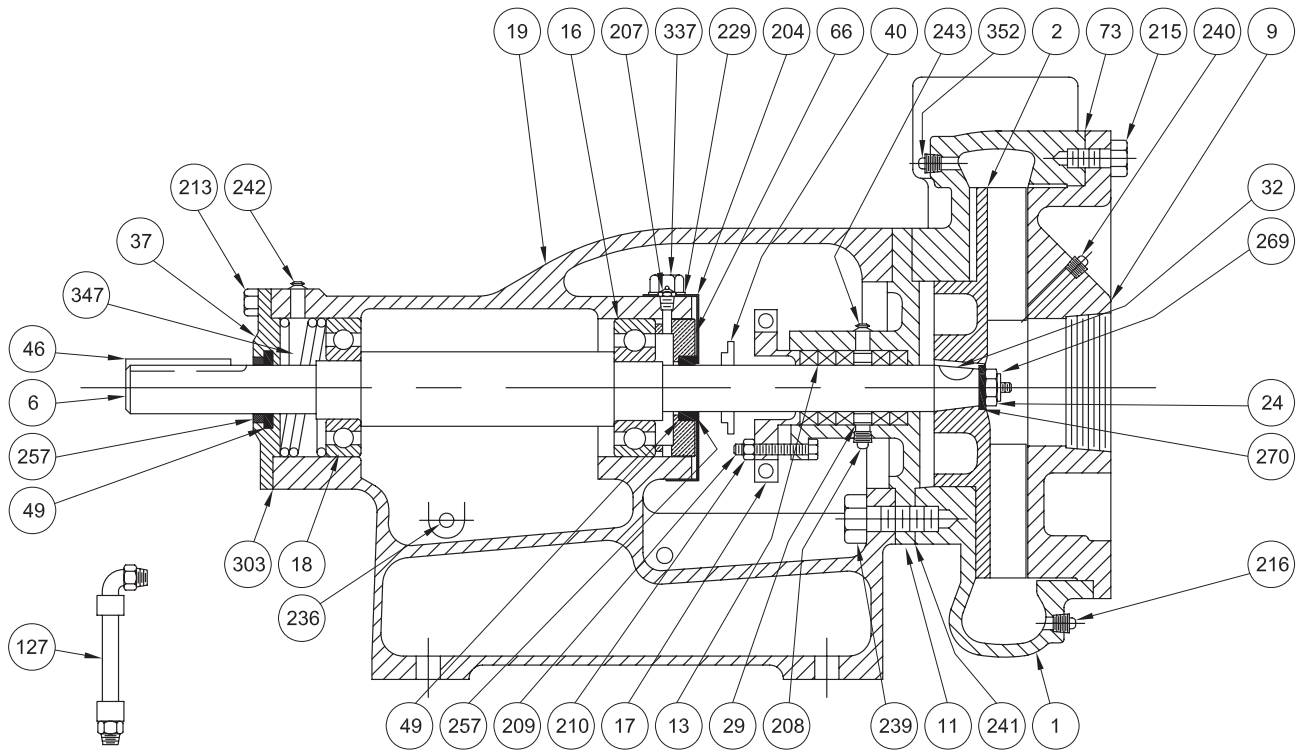
### O - LOCATING TROUBLE

1. No Liquid Delivered
  - a. Wrong direction of rotation
  - b. Speed too low - Check with revolution counter
  - c. Discharge head is too high
  - d. Impeller or pipe lines plugged
  - e. Pump not primed
  - f. Suction lift too high, over 15 feet (check with vacuum gauge)
2. Not Enough Liquid Delivered
  - a. Discharge head higher than anticipated
  - b. Speed too low (check with revolution counter)
  - c. Air leaks in suction pipe or stuffing box.
  - d. Suction lift too high, over 15 feet (check with vacuum gauge)
  - e. Impeller partially plugged
  - f. Not enough suction head for hot water
  - g. Mechanical defects
    1. Impeller worn or damaged
    2. Casing worn
  - h. Foot valve too small

i. Foot valve not immersed deep enough.

3. Not Enough Pressure
  - a. Air in water
  - b. Mechanical defects
  - c. Impeller diameter too small
  - d. Speed too low
4. Pump Works for a while, then Quits
  - a. Leaky suction line
  - b. Suction plugged
  - c. Suction lift too high, over 15 feet (check with vacuum gauge)
  - d. Air or gas in liquid
5. Pump Takes Too Much Power
  - a. Speed too high
  - b. Head lower than rating
  - c. Liquid either viscous or heavier than water, or both.
  - d. Mechanical defects
    1. Shaft is bent
    2. Impeller binds in casing
    3. Stuffing box packing too tightly adjusted.

When ordering repairs, refer to drawing and give information stamped on nameplate which is: Figure Number, Pump Size and Serial Number. Unless we have this information, we cannot identify pump and guarantee the repairs to fit.



Item No.	Name of Part	Item No.	Name of Part	Item No.	Name of Part
1	Casing	*49	Bearing Cover Seal (Outboard)	236	Pipe Plug
2	Impeller	66	Shaft Adjusting Unit	239	Cap Screws
6	Pump Shaft	*73	Casing Gasket	240	Pipe Plug
9	Suction Cover	127	Tubing Assembly with Connectors	*241	Stuffing Box Gasket
11	Packing Box Cover			242	Grease Fitting
*13	Packing	203	Name Plate	243	Grease Fitting
*16	Ball Bearing (Inboard)	204	Adjusting Lock Nut	257	Clamping Ring
17	Split Gland	207	Grease Fitting		
*18	Ball Bearing (Outboard)	208	Pipe Plug	*269	Cotter Pin
19	Frame	209	Cap Screw, Machine Bolt, or Stud	270	Impeller Washer
24	Impeller Nut	210	Hex Nut		
*29	Lantern Ring	213	Cap Screw	*303	Bearing Cover Gasket
32	Impeller Key	214	Drive Screw	337	Cap Screw
37	Bearing Cover (Outboard)	215	Cap Screws	347	Spring
40	Deflector	216	Pipe Plug	352	Pipe Plug
46	Coupling Key	229	Lockwasher		

\* Recommended spare parts

BARNES®



burks®

WEINMAN®

DEMING®

PROSSER®

## *Limited 24 Month Warranty*

Crane Pumps & Systems warrants that products of our manufacture will be free of defects in material and workmanship under normal use and service for twenty-four (24) months after manufacture date, when installed and maintained in accordance with our instructions. This warranty gives you specific legal rights, and there may also be other rights which vary from state to state. In the event the product is covered by the Federal Consumer Product Warranties Law (1) the duration of any implied warranties associated with the product by virtue of said law is limited to the same duration as stated herein, (2) this warranty is a LIMITED WARRANTY, and (3) no claims of any nature whatsoever shall be made against us, until the ultimate consumer, his successor, or assigns, notifies us in writing of the defect, and delivers the product and/or defective part(s) freight prepaid to our factory or nearest authorized service station. Some states do not allow limitations on how long an implied warranty lasts, so the above limitation may not apply. **THE SOLE AND EXCLUSIVE REMEDY FOR BREACH OF ANY AND ALL WARRANTIES WITH RESPECT TO ANY PRODUCT SHALL BE TO REPLACE OR REPAIR AT OUR ELECTION, F.O.B. POINT OF MANUFACTURE OR AUTHORIZED REPAIR STATION, SUCH PRODUCTS AND/OR PARTS AS PROVEN DEFECTIVE. THERE SHALL BE NO FURTHER LIABILITY, WHETHER BASED ON WARRANTY, NEGLIGENCE OR OTHERWISE.** Unless expressly stated otherwise, guarantees in the nature of performance specifications furnished in addition to the foregoing material and workmanship warranties on a product manufactured by us, if any, are subject to laboratory tests corrected for field performance. Any additional guarantees, in the nature of performance specifications must be in writing and such writing must be signed by our authorized representative. Due to inaccuracies in field testing if a conflict arises between the results of field testing conducted by or for user, and laboratory tests corrected for field performance, the latter shall control. **RECOMMENDATIONS FOR SPECIAL APPLICATIONS OR THOSE RESULTING FROM SYSTEMS ANALYSES AND EVALUATIONS WE CONDUCT WILL BE BASED ON OUR BEST AVAILABLE EXPERIENCE AND PUBLISHED INDUSTRY INFORMATION. SUCH RECOMMENDATIONS DO NOT CONSTITUTE A WARRANTY OF SATISFACTORY PERFORMANCE AND NO SUCH WARRANTY IS GIVEN.**

This warranty shall not apply when damage is caused by (a) improper installation, (b) improper voltage (c) lightning (d) excessive sand or other abrasive material (e) scale or corrosion build-up due to excessive chemical content. Any modification of the original equipment will also void the warranty. We will not be responsible for loss, damage or labor cost due to interruption of service caused by defective parts. Neither will we accept charges incurred by others without our prior written approval.

This warranty is void if our inspection reveals the product was used in a manner inconsistent with normal industry practice and/or our specific recommendations. The purchaser is responsible for communication of all necessary information regarding the application and use of the product. **UNDER NO CIRCUMSTANCES WILL WE BE RESPONSIBLE FOR ANY OTHER DIRECT OR CONSEQUENTIAL DAMAGES, INCLUDING BUT NOT LIMITED TO TRAVEL EXPENSES, RENTED EQUIPMENT, OUTSIDE CONTRACTOR FEES, UNAUTHORIZED REPAIR SHOP EXPENSES, LOST PROFITS, LOST INCOME, LABOR CHARGES, DELAYS IN PRODUCTION, IDLE PRODUCTION, WHICH DAMAGES ARE CAUSED BY ANY DEFECTS IN MATERIAL AND/OR WORKMANSHIP AND/OR DAMAGE OR DELAYS IN SHIPMENT. THIS WARRANTY IS EXPRESSLY IN LIEU OF ANY OTHER EXPRESS OR IMPLIED WARRANTY, INCLUDING ANY WARRANTY OF MERCHANTABILITY OR FITNESS FOR A PARTICULAR PURPOSE.**

No rights extended under this warranty shall be assigned to any other person, whether by operation of law or otherwise, without our prior written approval.

**CRANE**<sup>®</sup>

A Crane Co. Company

**PUMPS & SYSTEMS**

420 Third Street  
Piqua, Ohio 45356  
Phone: (937) 778-8947  
Fax: (937) 773-7157  
www.cranepumps.com

83 West Drive, Brampton  
Ontario, Canada L6T 2J6  
Phone: (905) 457-6223  
Fax: (905) 457-2650

**IMPORTANT!  
WARRANTY REGISTRATION**

Your product is covered by the enclosed Warranty.  
To complete the Warranty Registration Form go to:

<http://www.cranepumps.com/ProductRegistration/>

If you have a claim under the provision of the warranty, contact your local  
Crane Pumps & Systems, Inc. Distributor.

**RETURNED GOODS**

**RETURN OF MERCHANDISE REQUIRES A "RETURNED GOODS AUTHORIZATION".  
CONTACT YOUR LOCAL CRANE PUMPS & SYSTEMS, INC. DISTRIBUTOR.**



**Products Returned Must Be Cleaned, Sanitized,  
Or Decontaminated As Necessary Prior To Shipment,  
To Insure That Employees Will Not Be Exposed To Health  
Hazards In Handling Said Material. All Applicable Laws  
And Regulations Shall Apply.**



A Crane Co. Company

# PUMPS & SYSTEMS

## START-UP REPORT

### General Information

Pump Owner's Name: \_\_\_\_\_  
 Address: \_\_\_\_\_  
 Location of Installation: \_\_\_\_\_  
 Contact Person: \_\_\_\_\_ Phone: \_\_\_\_\_  
 Purchased From: \_\_\_\_\_

### Nameplate Data

Pump Model #: \_\_\_\_\_ Serial #: \_\_\_\_\_  
 Part #: \_\_\_\_\_ Impeller Diameter: \_\_\_\_\_  
 Voltage: \_\_\_\_\_ Phase: \_\_\_\_\_ Ø Hertz: \_\_\_\_\_ Horsepower: \_\_\_\_\_  
 Full Load Amps: \_\_\_\_\_ Service Factor Amps: \_\_\_\_\_  
 Motor Manufacturer: \_\_\_\_\_

### Controls

Control panel manufacturer: \_\_\_\_\_  
 Model/Part number: \_\_\_\_\_  
 Number of pumps operated by control panel: \_\_\_\_\_  
 Short circuit protection? YES\_\_\_ NO\_\_\_ Type: \_\_\_\_\_  
 Number and size of short circuit device(s): \_\_\_\_\_ Amp rating: \_\_\_\_\_  
 Overload Type: \_\_\_\_\_ Size: \_\_\_\_\_ Amp rating: \_\_\_\_\_  
 Do protection devices comply with pump and motor Amp rating? YES\_\_\_ NO\_\_\_  
 Are all electrical and panel entry connections tight? YES\_\_\_ NO\_\_\_  
 Is the interior of the panel dry? YES\_\_\_ NO\_\_\_  
 Liquid level Control Brand and Model: \_\_\_\_\_

### Pre-Startup

#### All Pumps

Type of equipment: NEW\_\_\_ REBUILT\_\_\_ USED\_\_\_  
 Condition of equipment at Start-Up: DRY\_\_\_ WET\_\_\_ MUDDY\_\_\_  
 Was Equipment Stored? YES\_\_\_ NO\_\_\_ Length of Storage: \_\_\_\_\_  
 Liquid being pumped: \_\_\_\_\_ Liquid Temperature: \_\_\_\_\_  
 Supply Voltage/Phase/Frequency matches nameplate? YES\_\_\_ NO\_\_\_  
 Shaft turns freely? YES\_\_\_ NO\_\_\_  
 Direction of rotation verified for 3Ø motors? YES\_\_\_ NO\_\_\_  
 Debris in piping or wet well? YES\_\_\_ NO\_\_\_  
 Debris removed in your presence? YES\_\_\_ NO\_\_\_  
 Pump case/wet well filled with liquid before startup? YES\_\_\_ NO\_\_\_  
 Is piping properly supported? YES\_\_\_ NO\_\_\_

#### Non-Submersible Pumps

Is base plate properly installed / grouted? YES\_\_\_ NO\_\_\_ N/A\_\_\_  
 Coupling Alignment Verified per I&O Manual? YES\_\_\_ NO\_\_\_ N/A\_\_\_  
 Grease Cup/Oil Reservoir Level checked? YES\_\_\_ NO\_\_\_ N/A\_\_\_

**Submersible Pumps**

Resistance of cable and pump motor (measured at pump control):

Red-Black: \_\_\_\_\_ Ohms(Ω) Red-White: \_\_\_\_\_ Ohms(Ω) White-Black: \_\_\_\_\_ Ohms(Ω)

Resistance of Ground Circuit between Control Panel and outside of pump: \_\_\_\_\_ Ohms(Ω)

MEG Ohms check of insulation:

Red to Ground: \_\_\_\_\_ White to Ground: \_\_\_\_\_ Black to Ground: \_\_\_\_\_

**Operational Checks**

Is there noise or vibration present? YES\_\_\_ NO\_\_\_ Source of noise/vibration: \_\_\_\_\_

Does check valve operate properly? YES\_\_\_ NO\_\_\_ N/A\_\_\_

Is system free of leaks? YES\_\_\_ NO\_\_\_ Leaks at: \_\_\_\_\_

Does system appear to operate at design flow rate? YES\_\_\_ NO\_\_\_

Nominal Voltage: \_\_\_\_\_ Phase: 1Ø 3Ø (select one)

Voltage Reading at panel connection, Pump OFF: L1, L2 \_\_\_\_\_ L2, L3 \_\_\_\_\_ L1, L3 \_\_\_\_\_

Voltage Reading at panel connection, Pump ON: L1, L2 \_\_\_\_\_ L2, L3 \_\_\_\_\_ L1, L3 \_\_\_\_\_

Amperage Draw, Pump ON: L1 \_\_\_\_\_ L2 \_\_\_\_\_ L3 \_\_\_\_\_

**Submersible Pumps**

Are BAF and guide rails level / plumb? YES\_\_\_ NO\_\_\_

Is pump seated on discharge properly? YES\_\_\_ NO\_\_\_

Are level controls installed away from turbulence? YES\_\_\_ NO\_\_\_

Is level control operating properly? YES\_\_\_ NO\_\_\_

Is pump fully submerged during operation? YES\_\_\_ NO\_\_\_

**Follow up/Corrective Action Required**

YES\_\_\_ NO\_\_\_

**Additional Comments:**

\_\_\_\_\_  
\_\_\_\_\_  
\_\_\_\_\_  
\_\_\_\_\_  
\_\_\_\_\_  
\_\_\_\_\_  
\_\_\_\_\_

Startup performed by: \_\_\_\_\_ Date: \_\_\_\_\_

**Present at Start-Up**

( ) Engineer: \_\_\_\_\_ ( ) Operator: \_\_\_\_\_

( ) Contactor: \_\_\_\_\_ ( ) Other: \_\_\_\_\_

**All parties should retain a copy of this report for future trouble shooting/reference**



**PUMPS & SYSTEMS**

A Crane Co. Company

420 Third Street  
Piqua, Ohio 45356  
Phone: (937) 778-8947  
Fax: (937) 773-7157  
www.cranepumps.com

83 West Drive, Brampton  
Ontario, Canada L6T 2J6  
Phone: (905) 457-6223  
Fax: (905) 457-2650