

 **GOULDS PUMPS**

Installation, Operation, and Maintenance Manual

AF (6"-36") MXR Bearings

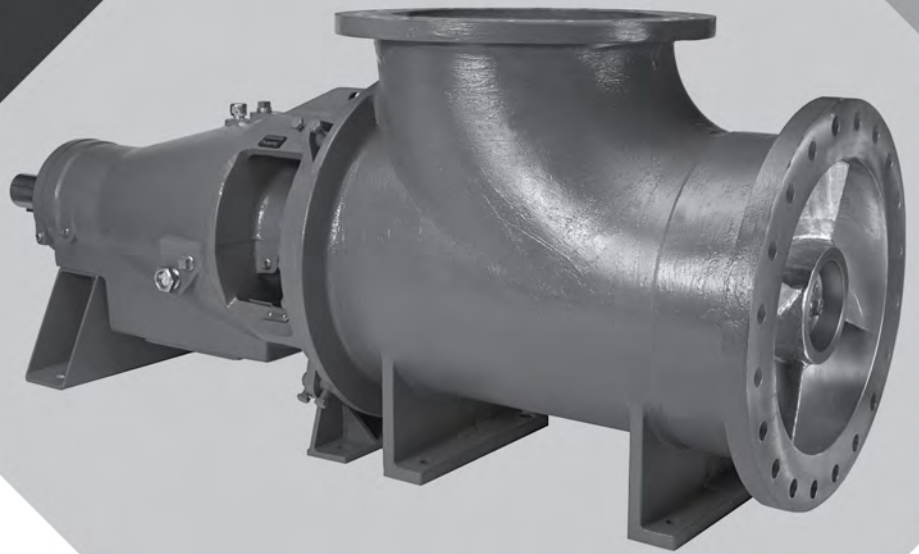

ITT

ENGINEERED FOR LIFE

Table of Contents

Introduction and Safety	4
Introduction	4
Safety	4
Safety terminology and symbols	4
Environmental safety	5
User safety	6
Precautions before work	6
Precautions during work	7
Safety regulations for Ex-approved products in potentially explosive atmospheres	7
Product approval standards	8
Product warranty	8
Transportation and Storage	9
Inspect the delivery	9
Inspect the package	9
Inspect the unit	9
Transportation guidelines	9
Pump handling	9
Lifting methods	9
Storage guidelines	10
Pump storage requirements	10
Uncrating / De-Skidding	11
Product Description	12
General Description	12
Nameplate information	15
Installation	17
Preinstallation	17
Foundation Requirements	17
Sub-base Leveling	18
Spring Mounted Base	20
Remove Spring from Spring Pocket	23
Pipe support design requirements	24
Install the pump to the piping	25
Connection of Piping	27
Drive Alignment Procedures	28
V-Belt Drive (Sheaves)	29
Gear Drive (Couplings)	31
Impeller Alignment	34
Align the impeller (Type 1)	35
Align the impeller (Type 2)	35
Align the Impeller and Packing/Mechanical Seal (Type 3)	37
Rotation Check	39
Impeller alignment worksheet	40
Commissioning, Startup, Operation, and Shutdown	41
Preparation for start-up	41
Start the Pump	45
Operation	47
Shut down the pump	49
Final Alignment	49

Maintenance	50
Preventative Maintenance	50
Maintenance schedule	50
Bearing Maintenance	51
Oil Lubricated Bearings	51
Grease lubricated bearings (6-18 inch sizes only)	52
Shaft-seal maintenance	53
Mechanical-seal maintenance	53
Packed stuffing-box maintenance	54
Packed Stuffing Box	54
Connection of Sealing Liquid	55
Labyrinth Seals	56
Disassembly	57
Pump Disassembly Precautions	57
Disassembly precautions	57
Remove the coupling guard	58
Tools required	59
Disassemble the guard / drive (v-belt configuration)	60
Disassemble the back-pullout / elbow (cast back-pullout design only)	63
Disassemble the back-pullout elbow with casing (cast back-pullout design only)	64
Disassemble the power frame from elbow (fabricated elbow design only)	65
Remove the liner (option)	69
Remove the standard impeller	69
Remove the sealed impeller	70
Remove mechanical seal with optional adapter (cast back-pullout design only)	71
Remove the Mechanical Seal (Fabricated Elbow Design only)	71
Disassemble the packed box (cast back-pullout design only)	72
Remove the Packing Chamber(Fabricated Elbow Design Only)	73
Remove the drip pan	73
Disassemble the bearing housing	74
Remove the bearing (1MXR-3MXR configuration)	77
Remove the bearing (4MXR-6MXR configuration)	78
Disassemble the cooling coil (optional) sight glass / breather and plugs	79
Pre-assembly inspections	80
Inspect the elbow / casing / liner (options)	80
Inspect impeller vane	80
Inspect the shaft	81
Inspect the shaft sleeve	81
Inspect the mechanical seal / restrictor bushing	82
Inspect the stuffing box (packed pumps only)	82
Inspect the bearing housing	82
Inspect the bearings	83
Labyrinth seals and O-rings	83
Critical axial flow dimensions and tolerances	84
Maximum bolt torque values N-M Ft-Lb	84
Reassembly	85
Reassemble the cooling coil (optional) sight glass / breather and plugs	85
Reassemble the rotating element (1MXR-3MXR configurations)	85
Reassemble the rotating element (4MXR-6MXR configurations)	86
Reassemble the bearing housing	87
Reassemble the drip pan	90
Reassemble the packed box (cast back-pullout design only)	91
Reassembly of the Packing Chamber (Fabricated Elbow Design only)	91
Reassemble the mechanical seal with optional adapter (cast back-pullout design only)	92

Reassembly of the Mechanical Seal (Fabricated Elbow Design Only)	93
Reassembly of Cast Back-Pullout Pumps Only	94
Reassemble the standard impeller	94
Reassemble the sealed impeller (cast back-pullout design only)	94
Reassemble the back-pullout elbow (cast back-pullout design only)	95
Reassemble the back-pullout elbow with casing	96
Reassemble the back-pullout liner (option)	97
Reassembly of Fabricated Non Back-Pullout Pumps	97
Reassemble the Elbow (Fabricated Elbow Design Only)	97
Reassemble the Standard Impeller (Fabricated Elbow Design Only)	98
Reassemble the Sealed Impeller (Fabricated Elbow Design Only)	98
Align the Propeller to the Elbow (Fabricated Elbow Design Only)	99
Align the Mechanical Seal Adapter and Install the Mechanical Seal (Fabricated Elbow Design Only)	100
Align the Packing Chamber and Install the Packing (Fabricated Elbow Design Only)	101
Reassemble the drive / guard (v-belt configuration)	102
Reassemble the drive / guard (direct connect configuration)	104
Troubleshooting	107
Pump Troubleshooting	107
Parts Listings and Cross-Sectionals	112
Cross sectional drawing (shown with optional restrictor bushing adapter)	112
Parts list and materials of construction	113
Cross sectional, AF with packing, non back-pullout	115
Cross sectional, AF with mechanical seal, non back-pullout	115
Parts list and materials of construction for fabricated elbows	116
MXR bearing configurations	118
AF with separate casing	119
AF options	120
Appendix	121
Bearing alignment	121
Maximum bolt torque values N-M Ft-Lb	122
Appendix II	123
Installation and Removal of the 30 inch and 36 inch Impeller Using the Goulds Impeller Assembly Tool	123

Introduction and Safety

Introduction

Purpose of this manual

The purpose of this manual is to provide necessary information for:

- Installation
- Operation
- Maintenance



CAUTION:

Read this manual carefully before installing and using the product. Improper use of the product can cause personal injury and damage to property, and may void the warranty.

NOTICE:

Save this manual for future reference, and keep it readily available at the location of the unit.

Safety



WARNING:

- The operator must be aware of safety precautions to prevent physical injury.
 - Any pressure-containing device can explode, rupture, or discharge its contents if it is over-pressurized. Take all necessary measures to avoid over-pressurization.
 - Operating, installing, or maintaining the unit in any way that is not covered in this manual could cause death, serious personal injury, or damage to the equipment. This includes any modification to the equipment or use of parts not provided by ITT. If there is a question regarding the intended use of the equipment, please contact an ITT representative before proceeding.
 - Do not change the service application without the approval of an authorized ITT representative.
 - Never operate the pump without safety devices installed.
 - Never operate the pump with the discharge valve closed.
 - The pump can handle hazardous and toxic fluids. Identify the contents of the pump and observe proper decontamination procedures in order to eliminate the possible exposure to any hazardous or toxic fluids. Wear the proper personal protective equipment. Potential hazards include, but are not limited to, high temperature, flammable, acidic, caustic, explosive, and other risks. You must handle and dispose of pumped fluid in compliance with the applicable environmental regulations.
-



Safety terminology and symbols

About safety messages

It is extremely important that you read, understand, and follow the safety messages and regulations carefully before handling the product. They are published to help prevent these hazards:

- Personal accidents and health problems
- Damage to the product
- Product malfunction

Hazard levels

Hazard level	Indication
 DANGER:	A hazardous situation which, if not avoided, will result in death or serious injury
 WARNING:	A hazardous situation which, if not avoided, could result in death or serious injury
 CAUTION:	A hazardous situation which, if not avoided, could result in minor or moderate injury
NOTICE:	<ul style="list-style-type: none"> • A potential situation which, if not avoided, could result in undesirable conditions • A practice not related to personal injury

Hazard categories

Hazard categories can either fall under hazard levels or let specific symbols replace the ordinary hazard level symbols.

Electrical hazards are indicated by the following specific symbol:



Electrical Hazard:

These are examples of other categories that can occur. They fall under the ordinary hazard levels and may use complementing symbols:

- Crush hazard
- Cutting hazard
- Arc flash hazard

Environmental safety

The work area

Always keep the pump station clean to avoid and/or discover emissions.

Recycling guidelines

Always recycle according to these guidelines:

1. If the unit or parts are accepted by an authorized recycling company, then follow local recycling laws and regulations.
2. If the unit or parts are not accepted by an authorized recycling company, then return them to the nearest ITT representative.

Waste and emissions regulations

Observe these safety regulations regarding waste and emissions:

- Dispose appropriately of all waste.
- Handle and dispose of the pumped fluid in compliance with applicable environmental regulations.
- Clean up all spills in accordance with safety and environmental procedures.

- Report all environmental emissions to the appropriate authorities.

Reference for electrical installation

For electrical installation requirements, consult your local electric utility.

User safety

General safety rules

These safety rules apply:

- Always keep the work area clean.
- Pay attention to the risks presented by gas and vapors in the work area.
- Avoid all electrical dangers. Pay attention to the risks of electric shock or arc flash hazards.
- Always bear in mind the risk of drowning, electrical accidents, and burn injuries.

Safety equipment

Use safety equipment according to the company regulations. Use this safety equipment within the work area:

- Helmet
- Safety goggles, preferably with side shields
- Protective shoes
- Protective gloves
- Gas mask
- Hearing protection
- First-aid kit
- Safety devices

NOTICE:

Never operate a unit unless safety devices are installed. Also see specific information about safety devices in other sections of this manual.

Electrical connections

Electrical connections must be made by certified electricians in compliance with all international, national, state, and local regulations. For more information about requirements, see sections dealing specifically with electrical connections.

Precautions before work

Observe these safety precautions before you work with the product or are in connection with the product:

- Provide a suitable barrier around the work area, for example, a guard rail.
- Make sure that all safety guards are in place and secure.
- Allow all system and pump components to cool before you handle them.
- Make sure that you have a clear path of retreat.
- Make sure that the product cannot roll or fall over and injure people or damage property.
- Make sure that the lifting equipment is in good condition.
- Use a lifting harness, a safety line, and a breathing device as required.
- Make sure that the product is thoroughly clean.
- Make sure that there are no poisonous gases within the work area.
- Make sure that you have quick access to a first-aid kit.

- Disconnect and lock out power before servicing.
- Check the explosion risk before you weld or use electric hand tools.

Precautions during work

Observe these safety precautions when you work with the product or are in connection with the product:

- Never work alone.
- Always wear protective clothing and hand protection.
- Stay clear of suspended loads.
- Always lift the product by its lifting device.
- Beware of the risk of a sudden start if the product is used with an automatic level control.
- Beware of the starting jerk, which can be powerful.
- Rinse the components in water after you disassemble the pump.

Safety regulations for Ex-approved products in potentially explosive atmospheres

Guidelines for compliance



WARNING:

Ex This manual clearly identifies accepted methods for disassembling units. These methods must be adhered to. Trapped liquid can rapidly expand and result in a violent explosion and injury. Never apply heat to impellers, propellers, or their retaining devices to aid in their removal unless explicitly stated in this manual.

If there are any questions regarding these requirements, the intended use, or if the equipment requires modification, contact an ITT representative before you proceed.

Personnel requirements

ITT disclaims all responsibility for work done by untrained and unauthorized personnel. These are the personnel requirements for Ex-approved products in potentially explosive atmospheres:

- **Ex** All work on the product must be carried out by certified electricians and ITT-authorized mechanics. Special rules apply to installations in explosive atmospheres.
- **Ex** All users must know about the risks of electric current and the chemical and physical characteristics of the gas and/or vapor present in hazardous areas.
- **Ex** Any maintenance for Ex-approved products must conform to international and national standards (for example IEC/EN 60079-17).

Product and product handling requirements

These are the product and product handling requirements for Ex-approved products in potentially explosive atmospheres:

- Only use the product in accordance with the approved motor data stated on the nameplates.
- The Ex-approved product must never run dry during normal operation. Dry running during service and inspection is only permitted outside the classified area.
- Before you start working with the product, make sure that the product and the control panel are isolated from the power supply and the control circuit, so they cannot be energized.
- Do not open the product while it is energized or in an explosive gas atmosphere.

- Make sure that thermal contacts are connected to a protection circuit according to the approval classification of the product.
- Intrinsically safe circuits are normally required for the automatic level-control system by the level regulator if mounted in zone 0.
- The yield stress of fasteners must be in accordance with the approval drawing and the product specification.
- Do not modify the equipment without approval from an authorized ITT representative.
- Only use parts that have been provided by an authorized ITT representative.

Equipment for monitoring

For additional safety, use condition-monitoring devices. Condition-monitoring devices include but are not limited to these devices:

Product approval standards

Regular standards

Product warranty

Coverage

ITT undertakes to remedy faults in products from ITT under these conditions:

- The faults are due to defects in design, materials, or workmanship.
- The faults are reported to an ITT representative within the warranty period.
- The product is used only under the conditions described in this manual.
- The monitoring equipment incorporated in the product is correctly connected and in use.
- All service and repair work is done by ITT-authorized personnel.
- Genuine ITT parts are used.
- Only Ex-approved spare parts and accessories authorized by ITT are used in Ex-approved products.

Limitations

The warranty does not cover faults caused by these situations:

- Deficient maintenance
- Improper installation
- Modifications or changes to the product and installation made without consulting ITT
- Incorrectly executed repair work
- Normal wear and tear

ITT assumes no liability for these situations:

- Bodily injuries
- Material damages
- Economic losses

Warranty claim

ITT products are high-quality products with expected reliable operation and long life. However, should the need arise for a warranty claim, then contact your ITT representative.

Transportation and Storage

Inspect the delivery

Inspect the package

1. Inspect the package for damaged or missing items upon delivery.
2. Note any damaged or missing items on the receipt and freight bill.
3. File a claim with the shipping company if anything is out of order.
If the product has been picked up at a distributor, make a claim directly to the distributor.

Inspect the unit

1. Remove packing materials from the product.
Dispose of all packing materials in accordance with local regulations.
2. Inspect the product to determine if any parts have been damaged or are missing.
3. If applicable, unfasten the product by removing any screws, bolts, or straps.
For your personal safety, be careful when you handle nails and straps.
4. Contact your sales representative if anything is out of order.

Transportation guidelines

Pump handling



WARNING:

- Make sure that the unit cannot roll or fall over and injure people or damage property.
 - These pumps might use carbon or ceramic silicon carbide components. Do not drop the pump or subject it to shock loads as this can damage the internal ceramic components.
-

NOTICE:

Use a forklift truck or an overhead crane with sufficient capacity to move the pallet with the pump unit on top. Failure to do so can result in equipment damage.

Lifting methods



WARNING:

- All lifting must be done in compliance with all applicable regulations/standards.
 - Assembled units and their components are heavy. Failure to properly lift and support this equipment can result in serious physical injury and/or equipment damage. Lift equipment only at the specifically identified lifting points. Lifting devices such as hoist rings, shackles, slings and spreaders must be rated, selected, and used for the entire load being lifted.
 - Crush hazard. The unit and the components can be heavy. Use proper lifting methods and wear steel-toed shoes at all times.
-

Examples

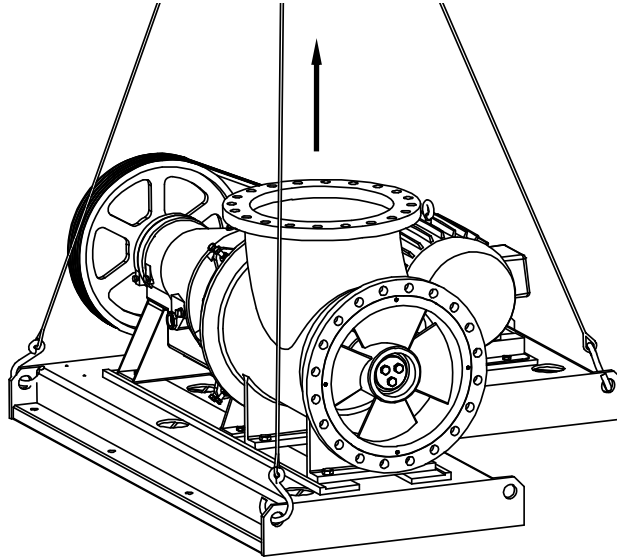

Figure 1: Example of proper lifting method from sub-base

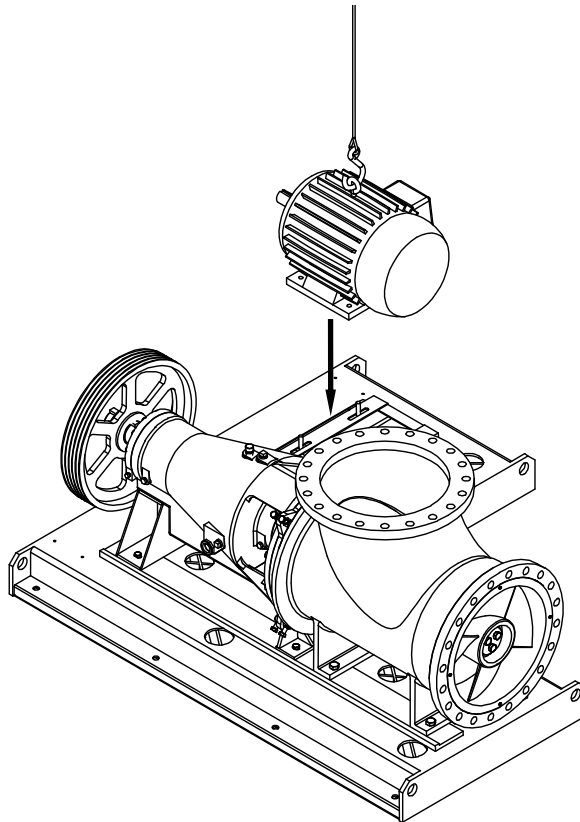

Figure 2: Example of proper lifting method of motor

Storage guidelines

Pump storage requirements

Storage requirements depend on the amount of time that you store the unit. The normal packaging is designed only to protect the unit during shipping.

Length of time in storage	Storage requirements
Upon receipt/short-term (less than six months)	<ul style="list-style-type: none">• Store in a covered and dry location.
Long-term (more than six months)	<ul style="list-style-type: none">• Store in a covered and dry location.• Store the unit free from heat, dirt, and vibrations.

Uncrating / De-Skidding

Care should be taken when uncrating or de-skidding pumps. If shipment is not delivered in proper order, and in accordance with the bill of lading, note the damage or shortage on both the receipt and freight bill. Make any claims to the transportation company promptly. Instruction books and sheets are included in the shipment - DO NOT DISCARD.

Product Description

General Description

The AF pump generates flow by the thrust or lift action of rotating axial vanes of the impeller. Axial flow pumps generate high flow rates and low head which are ideal for re-circulation, evaporator, and generator cooling systems. The AF has an elbow that directs the flow through the suction and out the discharge end of the pump. It can be used in the top or end suction configuration depending on the customer's needs.

Refer to original factory documentation for the arrangement of your pump. The model AF is based on (6) power ends and (12) hydraulic pump sizes. The first (3) power ends have ball bearings, the others have taper and spherical roller bearings. Groupings are as follows:

Table 1: Pump Description

Power End	Inboard Bearing	Outboard Bearing	Pump Size
1MXR	Ball	(2) Ang. Contact	6", 8", 10"
2MXR	Ball	(2) Ang. Contact	12", 14"
3MXR	Ball	(2) Ang. Contact	16", 18"
4MXR	Spherical Roller	Taper Roller	20", 24"
5MXR	Spherical Roller	Taper Roller	700mm, 30"
6MXR	Spherical Roller	Taper Roller	36"

Table 2: AF Bearings used by Size

Size	Radial Bearing SKF Part #	Thrust Bearing SKF Part #	
6"/8"/10"	6210	7309 BECBM	
12"/14"	6213	7313 BECBY	
16"/18"	6217	7316 BECBY	
	SKF Part #	Timken Part #	Bench End Play
20"/24"	23124CCK/W33	HH224340-90073	0.30mm 0.012"
700MM/30"	23130CC/W33	HH926749-90016	0.20mm 0.008"
36"	23134CC/W33	HH932145-902A4	0.15MM 0.006"

Elbow

- **Cast elbow with back pullout** - the elbow is cast with 150# flat face suction and discharge flanges, it comes with an opening in the rear for a back-pullout. The back-pullout consists of the bearing housing, shaft, and impeller. The elbow has cast feet for mounting to a sub-base or it can be mounted directly in the piping. It also comes with an optional elbow liner.
- **Fabricated elbow design without back pullout** - elbows are fabricated with 150# flat face suction and discharge flanges. They come with fabricated feet for mounting to a sub-base or without feet to be mounted directly in the piping. The elbows have a built in stuffing box and a rear flange for mounting the power end to the elbow. There are also adjusting lugs at the power frame to elbow joint for aligning the propeller to the elbow.

Elbow or Casing Liner (Optional)

An optional liner provides erosion and corrosion protection for longer elbow or casing life. It may also come with a serrated inside diameter for pumping stringy material. Available on cast elbow with back pullout design only.

Back Pullout (available on the cast design only)

The back-pullout is based on the (6) power ends listed previously. It consists of a bearing housing, bearings, stuffing box cover, locknuts, lockwashers, labyrinth oil seals, shaft, shaft sleeve (w/packing), oil slinger (20"~36"), impeller, keys, shaft washer, and a front and back foot.

Stuffing box cover

- **Cast elbow design** - the cast stuffing box cover is used to close the rear of the elbow and provide a mounting surface for a mechanical seal or stuffing box and gland. Inside it has a machined flat face with a (3) or (4) bolt pattern to accept a stuffing box or standard cartridge mechanical seal. When used with a mechanical seal it has a cast in 5 deg. taper bore opening to assist in ejecting particles from the seal area. The cover comes with adjusting ears that allow for centering on the shaft and also to center the impeller in the elbow.
- **Fabricated elbow design** - the stuffing box is integral with the elbow.

Mechanical Seal Adapter (Optional on Cast and Fabricated Designs)

An optional adapter is used when the mechanical seal requires a restrictor bushing. The restrictor bushing is supplied with the adapter.

Optional

Packed Stuffing Box (Cast Elbow Design)

The stuffing box is cast and is separate from the elbow and stuffing box cover. It comes with a replaceable wear sleeve that is keyed to the shaft. Included are 5 rings of packing and a lantern ring to seal the shaft area. Two flush ports provide packing lubrication. A gland is used for packing adjustment. The stuffing box can also be modified to accept a mechanical seal if required.

Packed Stuffing Box (Fabricated Elbow Design)

A separate alignable mechanical seal adapter provides a mounting surface for a mechanical seal. A separate alignable packing chamber with flush ports is provided for packing. The standard packed box includes (5) rings of packing and a lantern ring to seal the shaft area. A gland is used for packing adjustment.

Shaft Sleeve (Cast and Fabricated Elbows)

If packing is specified, a replaceable wear sleeve is provided with the power end. The sleeve is keyed to prevent rotation.

Casing (Cast Design Only)

A sacrificial wear casing is provided on the 700mm and 36" sizes. Adjusting lugs are used to center the casing relative to the impeller. The casing has 150# flanges for mounting to the elbow and comes with an optional liner.

Impeller

The impeller is cast with (4) fixed vanes. It is machined with internal steps for easy assembly onto the shaft. It comes configured for 0 or +5 degree, clockwise or counterclockwise rotation, and top or end suction. The impeller is held in place with a shaft washer and bolts. The 700mm and 36" impellers come with cover plates and o-rings, to seal them from the pumpage. The seal prevents corrosion and allows for easy impeller replacement. The impeller is dynamically balanced (double plane) per ISO 1940 to a quality grade G-16.

Shaft

The shaft is cantilevered into the pump elbow to eliminate the need for internal bearings. It is designed to have small deflections, high critical speeds, and corrosion resistance. The shafts are stepped for easy assembly with the impeller.

Bearings

The inboard radial bearing absorbs radial loads and aligns the pump shaft. It is either a ball or spherical roller bearing, depending on pump size. The outboard thrust bearing absorbs thrust loads and comes as either back-to-back angular contacts or a single taper roller bearing, depending on pump size. Lubrication is by flood oil or grease (grease not available on sizes 20 inch and above) depending on customer requirements.

Oil Cooling (Optional)

An oil cooling option is available on 12" and larger sizes. A coiled tube mounted inside the bearing housing circulates water to cool the oil bath. It is attached to the bottom of the bearing housing by a removable bottom plate and gasket. It is generally used when process temperatures cause excessive heat build up in the bearing housing and or bearings.

Configuration and Drives

Most AF pumps are V-belt driven to allow for varying speeds. V-belts can be configured for side by side, overhead, under-slung, or vertical operation. The pumps can also be configured with gear reducers and or jack shafts for direct connect operation.

Maximum Sphere Size

The maximum solid size that the AF can pass depends on the pump size. The following are the maximum sphere sizes for each pump:

Table 3: Maximum Sphere Size

Pump Size	Sphere Size	Pump Size	Sphere Size
6"	1.5"	18"	4.5"
8"	2.0"	20"	5.0"
10"	2.5"	24"	6.0"
12"	3.0"	700mm	6.0"
14"	3.5"	30"	7.5"
16"	4.0"	36"	9.0"

Nameplate information

Important information for ordering

Every pump has nameplates that provide information about the pump. The nameplates are located on the bearing housing.

When you order spare parts, identify this pump information:

- Model
- Size
- Serial number
- Item numbers of the required parts

Refer to the nameplate on the bearing housing for most of the information. See Parts List for item numbers.

Nameplate on the casing using English units

Nameplate field	Explanation
S/N	Serial number of the pump
MODEL	Pump model
SIZE	Size of the pump
STD. DIM.	Standard ANSI dimensional code
HYRO PRESS PSI	Hydrostatic pressure at 100°F, in PSI
FLOW	Rated pump flow in GPM
R.P.M.	Rated pump speed, revolutions per minute
MAX. DES. WORKING PRESS., PSI	Maximum working pressure at temperature °F, in PSI
HEAD	Rated pump head, in feet
MAT'L.	Material of which the pump is constructed
IMP. DIA.	Impeller diameter, in inches
CONT./ITEM NO.	Customer contract or item number
MAX. DIA.	Maximum impeller diameter, in inches

Nameplate on the casing using Metric units

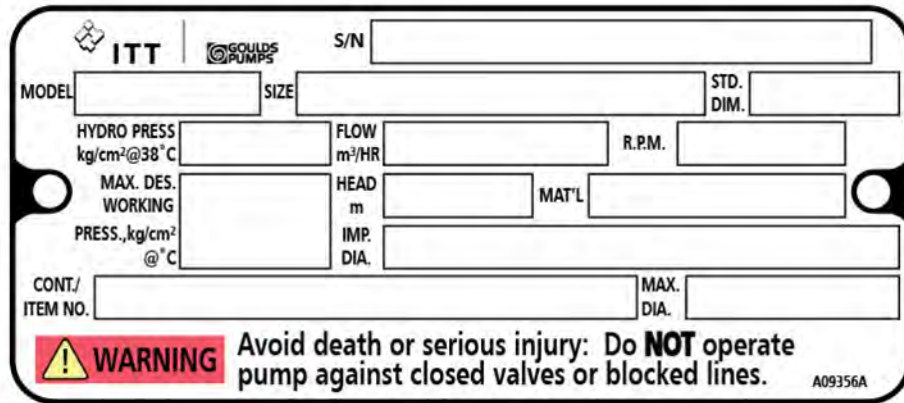

Nameplate field	Explanation
S/N	Serial number of the pump
MODEL	Pump model
SIZE	Size of the pump
STD. DIM.	Standard ANSI dimensional code
HYDRO PRESS	Hydrostatic pressure at 38° C, in kg/cm2
FLOW	Rated pump flow in m3/hr
R.P.M.	Rated pump speed, revolutions per minute
MAX. DES. WORKING PRESS. @ °C	Maximum working pressure at temperature °C, in kg/cm2
HEAD	Rated pump head, in m
MAT'L.	Material of which the pump is constructed
IMP. DIA.	Impeller diameter, in inches
CONT./ITEM NO.	Customer contract or item number
MAX. DIA.	Maximum impeller diameter, in inches

Installation

Preinstallation

AF units are usually shipped completely assembled. Check all bolts and nuts on the entire unit and make sure they are securely tightened.

If necessary install and adjust drive components per manufacturer's recommendations

⚠ Equipment that will operate in a potentially explosive environment must be installed in accordance with the following instructions.

⚠ All equipment being installed must be properly grounded to prevent unexpected static electric discharge. If not, a static electric discharge may occur when the pump is drained and disassembled for maintenance purposes.

Foundation Requirements

AF pump shall be located in a clean, dry area free from flooding. The area should provide adequate space for operation, maintenance, inspection and repair, considering complete disassembly and handling of equipment. The pump should have a supply of clean liquid for packing or mechanical seal lubrication. The pump shall be positioned to provide the most efficient pipeline system.

The AF pumps covered by these instructions may be designed to hang in the piping system, furnished with spring loaded sub-base bolts, or have a sub-base designed to be anchor bolted and grouted to the foundation.

The foundation must be substantial enough to absorb any vibration and form a permanent, rigid support for the pumping unit to the degree that there shall not be any adverse movement or settling over a long period of time.

Foundations for anchor bolted and grouted sub-bases are typically concrete with anchor bolts cast in to secure the pump.

The most commonly used foundation bolts are the sleeve-type.

Sleeve-type bolts

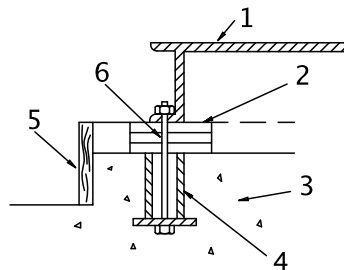

1. Baseplate
2. Shims or wedges
3. Foundation
4. Sleeve
5. Dam
6. Bolt

Figure 3: Sleeve type bolts

J-type bolts

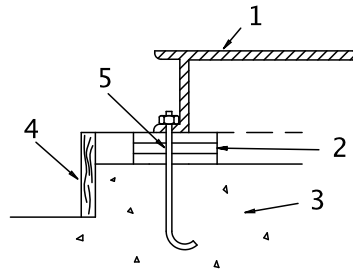

- 1. Baseplate
- 2. Shims or wedges
- 3. Foundation
- 4. Dam
- 5. Bolt

Figure 4: J-type bolts

Sub-base Leveling

Grouted Base

When the unit is received with the pump and driver mounted to the sub-base, it should be placed on the foundation and the coupling halves or V-belts disconnected (see Figure titled *Sub-base, top view*). The coupling should not be reconnected until all realignment operations have been completed. A recommended coupling alignment procedure is included in the following sections.

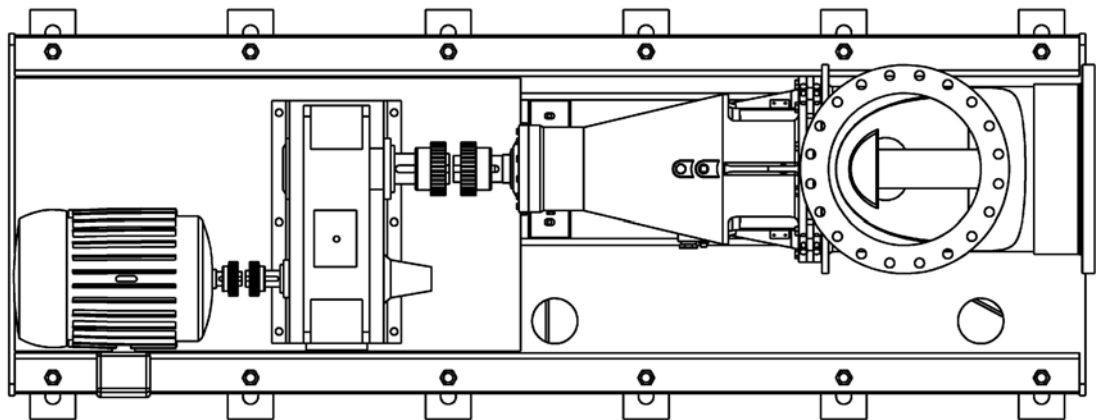

Figure 5: Sub-base, top view

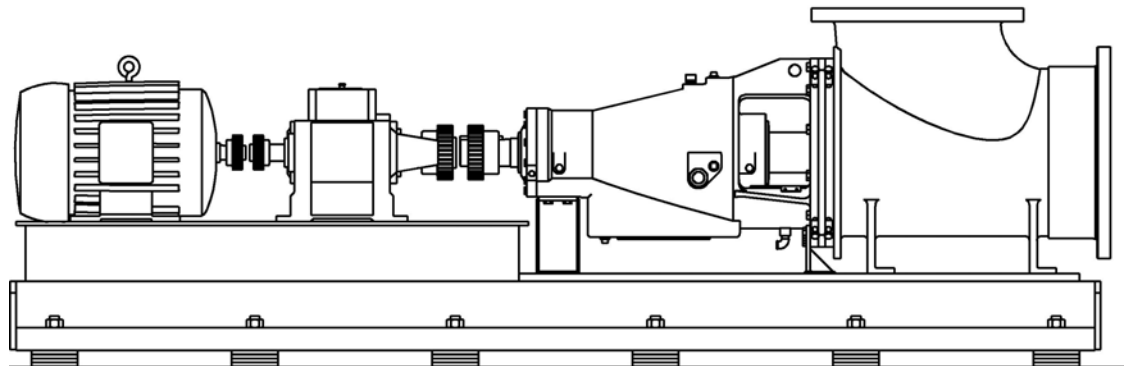
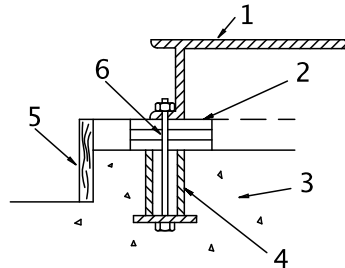

Figure 6: Sub-base, side view

1. The sub-base should be supported on rectangular metal blocks or on metal wedges having a slight taper. There should be support blocks or wedges on both sides of each foundation bolt. A gap of about 19mm | 3/4" to 38mm | 1-1/2" should be allowed between the sub-base and the foundation for grouting, see Figure titled *Sub-base, side view*.
2. Adjust the metal supports or wedges until the shafts of the pump and driver and sub-base are level. Check the coupling faces, as well as the suction and discharge flanges of the pump, for horizontal and vertical position by means of a level. Check also for any internal rubbing in the pump. Correct, if necessary, by adjusting the supports or wedges under the sub-base as required. In most cases, factory alignment will be regained by shimming under the sub-base alone. Provisions must be made to support the discharge piping independently from the pump to prevent excessive loads and maintain pump-driver alignment.
3. The sub-base should be level to within 3 mm | 0.125" over the length of the base and 1.5 mm | 0.0875" over the width of the base. Bases anchored with conventional foundation bolts use shims on both sides of the anchor bolts to level the base. The bolts which secure the pump sub-base to the foundation should be 3mm | 1/8" to 6mm | 1/4" less in diameter than the holes in the sub-base (hole size is shown on the certified installation drawing).
4. Clean outside areas of sub-base that will contact grout. Do not use oil-based cleaners because grout will not bond to it. Refer to grout manufacturer's instructions.
5. Build a dam around foundation and thoroughly wet the foundation.



1. Baseplate
2. Shims or wedges
3. Foundation
4. Sleeve
5. Dam
6. Bolt

Figure 7: Build dam around foundation

6. Pour grout through the grout holes in the sub-base, up to level of dam. Remove air bubbles from grout as it is poured by puddling, using a vibrator, or pumping the grout into place. Non-shrink grout is recommended.
7. Allow grout to set at least 48 hours.
8. Tighten foundation bolts.

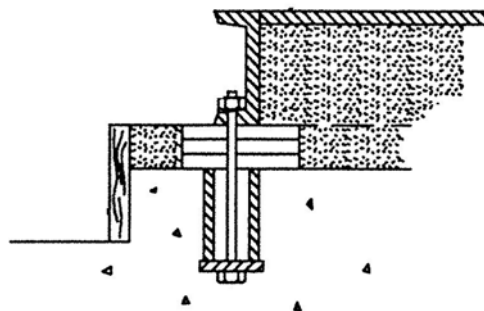
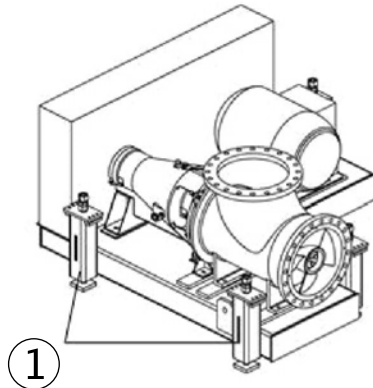

Figure 8: Tighten foundation bolts

Spring Mounted Base

The Figure: *V-belt Driven AF pump on spring mounted sub-base*, shows a V-belt driven AF pump on a spring mounted sub-base. Sub-bases supported by spring pockets assure that the pump remains level, regardless of vertical movement due to thermal pipe expansion during operation.



1. Spring pockets

Figure 9: V-belt Driven AF pump on spring mounted sub-base

The following is a brief description of the spring pocket components and their function (see Figure: *Spring pocket components*). The adjusting screw is used to compress or relax the spring. Turning the screw causes the adjusting screw nut assembly to move vertically and change the amount of force the spring exerts against the spring retainer, which is fastened to the sub-base. The stop nut is to limit the vertical up motion of the sub-base in case part of the load is removed from the pump unit when the system is cold. The jam nut keeps the stop nut from turning during normal operation when the sub-base has been pushed down from the thermal expansion. The adjusting screw holder is a bearing surface for the end of the adjusting screw and serves to hold the end of the screw in a fixed location.

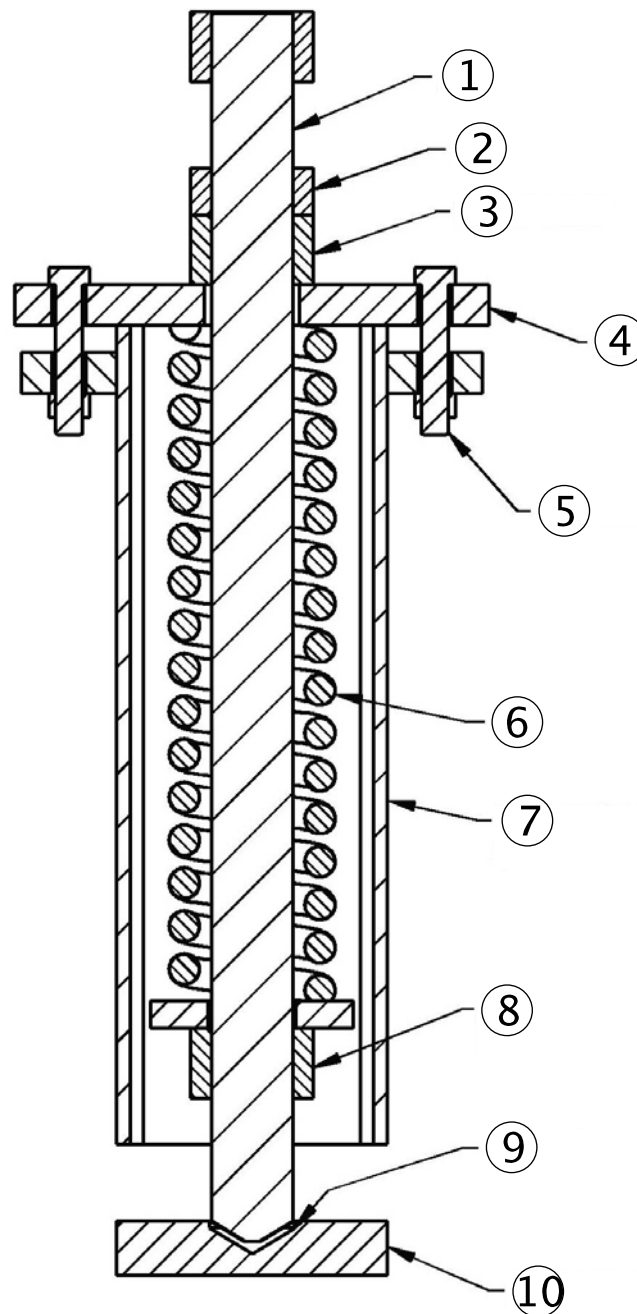

- | | |
|--------------------|---------------------------------------|
| 1. Adjusting screw | 6. Spring |
| 2. Jam nut | 7. Spring holder (welded to sub-base) |
| 3. Stop nut | 8. Adjusting screw nut assembly |
| 4. Spring retainer | 9. Lubricate with oil |
| 5. Bolts and nuts | 10. Adjusting screw holder |

Figure 10: Spring pocket components

The adjusting screw was lubricated at the factory but should be re-lubricated with heavy protective grease during the pump installation. The springs and other parts should be coated with an agent to protect the surface from corrosion, and a heavy lubricant should be applied to the adjusting screw holder pocket.

The following steps are used to set the springs and level the sub-base:

1. Place blocks under the sub-base, near each spring holder, and position the sub-base level on the blocks. A small gap (approx. 1.6 mm | 1/16") should exist between the flange of the vertical pipe and the pump elbow with the gasket in place (see Figure: *Blocks placed under sub-base*).
2. Install several flange bolts to help maintain alignment of the flanges.

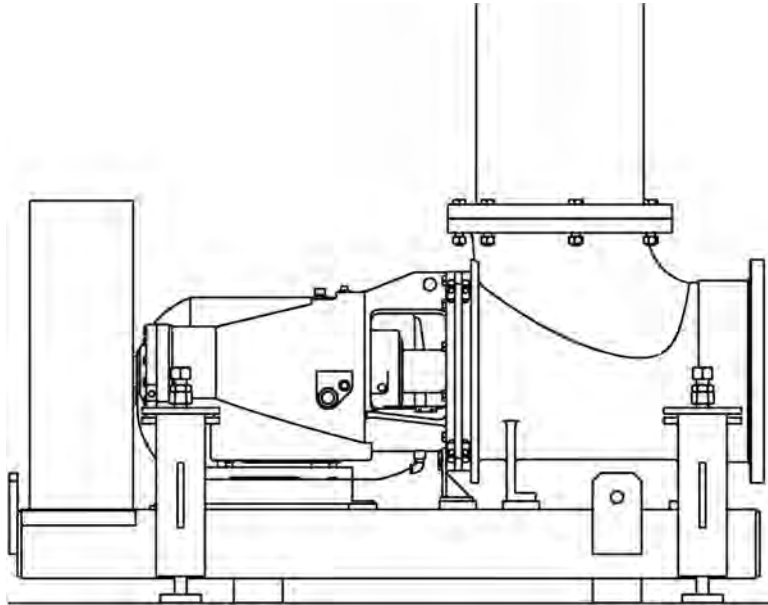

Figure 11: Blocks placed under sub-base



WARNING:
Do not tighten bolts.

3. Position the adjusting screw holders, while the adjusting screw end is seated in the hole, in the direction of the horizontal thermal expansion. This will allow the required horizontal motion without having the adjusting screw nut assembly hit the walls of the spring holder. Make sure there is sufficient clearance between the adjusting screw holder and the bottom of the sub-base for vertical thermal expansion, this clearance is usually shown on the pump installation drawing.

NOTICE: Each spring carries a share of the unit load but generally do not carry equal loads. Each holder has a small "window" to check the spring coil spacing, which is an indication of the relative load on the spring. The installation drawing may indicate the approximate number of turns required for each spring location, especially if the unit uses more than (4) springs. If necessary refer to Table: *Spring rate information*.

Table 4: Spring rate information

Spring Size	Wire Size	Spring Rate	Adjusting Screw Size	Load Change per Full Turn
1	.812"	1140 #/in.	1-1/2"-6 UNC	190 #
2	.750"	760 #/in.	1-1/2"-6 UNC	127 #
3	.532"	560 #/in.	1-1/2"-6 UNC	93 #
4	1.00"	1000 #/in.	2"-4-1/2 UNC	222 #
5	.375"	133 #/in.	3/4"-10 UNC	13 #

4. Turn the adjusting screws until the bottom of the sub-base just clears each block. Next adjust each screw evenly until the pump flange and gasket are less than 0.8 mm | 1/32" away from the pipe flange. Careful adjustment is necessary to keep the pump level and

obtain better weight distribution on the springs. After the springs have been loaded and adjusted, the base should be off the support blocks and level.

5. Check the alignment of the impeller and the pump elbow. If necessary, correct the alignment by adjusting the springs or by using shims.

NOTICE: If the flange gap is over 0.8 mm | 1/32", turn the adjusting screws a uniform amount to close the gap. For a gap of 0.8 mm | 1/32" or less, omit this step.

6. Tighten the vertical pipe flange bolts, recheck the alignment and connect the horizontal pipe flange to the elbow. The pump unit should be level and there should not be any rubbing of the impeller in the elbow when the shaft is turned by hand.
7. Run each stop nut down to make light contact with the spring retainer. Lock in place by turning the jam nut down tight against the stop nut.
8. Inspect each spring holder to check the gap between the coils of the spring. There must be enough total gap to accommodate the downward thermal expansion of the system without having them compressed solid.

NOTICE: Pumps with oil lubrication should be checked for oil level while thermal expansion is taking place. It may be necessary to add oil to the bearing housing to provide the proper oil level to the higher bearing. A line parallel with the sub-base deck through the proper oil level line will show the correct level at the highest end of the bearing housing. A horizontal line back from that point will establish the proper level mark on the sight gauge.

The system should be operated at normal temperature before the adjusting screw holders are grouted in place. Some customers operate their units with the adjusting screw holders ungrouted.

If it becomes necessary to remove a spring assembly from a spring pocket, for safety the following steps should be strictly adhered to:

Remove Spring from Spring Pocket

If it becomes necessary to remove a spring assembly from a spring pocket, for safety the following steps should be strictly adhered to:

1. Make sure the spring is relaxed. If the spring cannot be relaxed with the adjusting screw, the safest method is to pry off the Plexiglas cover and cut the coils using a torch.
2. Remove the bolts or cap screws, which fasten the spring retainer to the holder and lift out the entire assembly.
3. When the pump is connected to the system and a spring is removed, there should be support under the sub-base near the spring location until the spring has been replaced and adjusted. Distortion of the sub-base will affect the pump alignment, and the weight of the components is more likely to cause distortion when the pump is connected to the rigid pipe system.
4. If a spring is replaced while the system is hot, the stop nut should not be set until the system is cold. The springs must be allowed to push the base back to its cold position. An optional grease filled spring pocket is shown in Figure: *Grease filled spring pocket assembly*. The difference between the standard pocket and the grease filled pocket is the addition of a grease fitting and grease seal. Adjustment and setting of the grease filled pocket are identical.

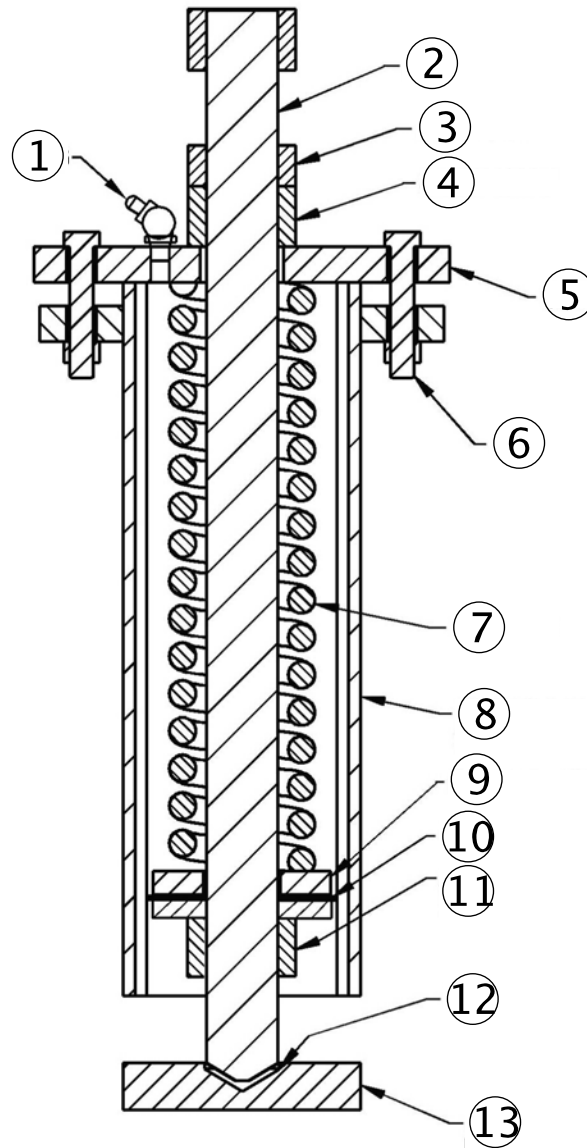

- | | |
|--------------------|---------------------------------------|
| 1. Grease fitting | 8. Spring holder (welded to sub-base) |
| 2. Adjusting screw | 9. Seal washer |
| 3. Jam nut | 10. Grease seal |
| 4. Stop nut | 11. Adjusting screw nut assembly |
| 5. Spring retainer | 12. Lubricate with oil |
| 6. Bolts and nuts | 13. Adjusting screw holder |
| 7. Spring | |

Figure 12: Grease filled spring pocket assembly

Pipe support design requirements

1. Piping supports must meet Hydraulic Institute, ASME/ANSI, DIN requirements, in conjunction with standard construction practices.
2. Piping shall be stiff enough to prevent unwanted pump vibrations.
3. Thermal expansion of the piping must be accounted for by the piping/system designer.
4. Refer to the installation/dimensional drawing for pump weights.
5. Refer to pump flange load drawing for allowable loads.

6. Follow the power transmission manufacturer's recommendations for angular limits and thermal movement of the pump relative to pump driver.

NOTICE:

Future access to the pump impeller and shaft will require removal of a section of the horizontal pipe. The piping shall have a spool piece for this purpose

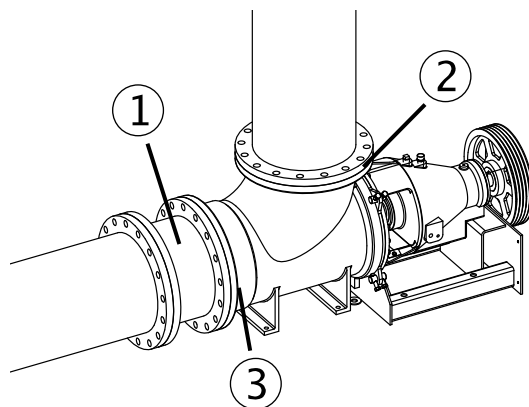

1 Spool piece

3 Lower flange

2 Upper flange

Figure 13: Spool piece in horizontal pump

Install the pump to the piping

1. Connect the elbow upper flange to the vertical pipe run and tighten the flange bolts.
2. Check the impeller clearance in the elbow/casing to be sure it is well centered using the criteria that the minimum gap at the vane O.D. is at least $\frac{1}{2}$ the maximum gap. See the [Impeller alignment worksheet](#) (page 40) of this IOM.
3. Connect the horizontal pipe or spool piece to the elbow lower flange and tighten the flange bolts.
4. Check pump for level. Pump should be less than $\frac{1}{2}$ degree (0.1"/ft) from horizontal so bearings are not starved of oil. Be sure thermal expansion does not cause this angle to be exceeded.

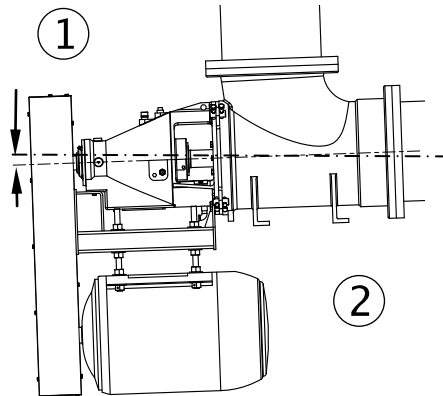

1. Must be less than 1/2 degree
2. Exaggerated for effect

Figure 14: Check pump for level

5. With the under-slung arrangement install the motor after the pump is connected to the piping. Be sure motor shaft is parallel to the pump shaft in the horizontal and vertical plane.

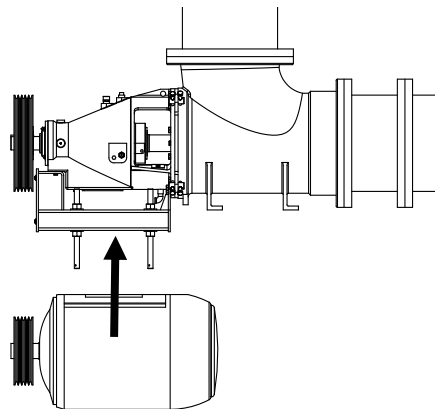

Figure 15: Motor shaft parallel to pump shaft

6. If pump unit is direct drive utilizing a drive shaft, refer to the drive shaft manufacturer's installation manual for mounting instructions.

NOTICE:

Pipe flanges must be parallel with the pump flange before the bolts are tightened. If the flanges are not parallel, forcing them parallel by tightening the bolts will cause excessive strain on the pump

Connection of Piping

General



WARNING:

Never draw piping into place by forcing at the flanged connections of the pump. This may impose dangerous strains on the unit and cause misalignment between pump and driver. Pipe strain will adversely effect the operation of the pump resulting in physical injury and damage to the equipment.

Guidelines for piping are given in the "Hydraulic Institutes Standards" available from: Hydraulic Institute, 30200 Detroit Road, Cleveland OH 44145-1967 and must be reviewed prior to pump installation.

1. All piping must be supported independently of, and line up with the pump flanges.
2. Piping runs should be as short as possible to minimize friction losses.
3. DO NOT connect piping to the pump until the pump and driver hold-down bolts have been tightened.
4. It is suggested that expansion loops or joints be properly installed in suction and /or discharge lines when handling liquids at elevated temperatures, so linear expansion of piping will not draw pump out of alignment.
5. The piping should be arranged to allow pump flushing prior to removal of the unit on services handling corrosive liquids.
6. Carefully clean all pipe parts, valves and fittings, and pump branches prior to assembly.

Suction and Discharge Piping



WARNING:

Net positive suction head available ($NPSH_A$) must always exceed NPSH required ($NPSH_R$) as shown on the published performance curve of the pump.

(Reference Hydraulic Institute for NPSH and pipe friction values needed to evaluate suction piping)

Properly installed suction piping is a necessity for trouble-free pump operation. Suction piping should be flushed BEFORE connection to the pump.

1. Use of elbows close to the pump suction flange should be avoided. There should be a minimum of 2 pipe diameters of straight pipe between the elbow and suction inlet. Where used, elbows should be long radius.
2. Use suction pipe one or two sizes larger than the pump suction, with a reducer at the suction flange. Suction piping should never be of smaller diameter than the pump suction.
3. To prevent suction cavitation, horizontal reducers should be eccentric with the sloping side down and concentric for vertical applications.
4. Pump must never be throttled on suction side.
5. Separate suction lines are recommended when more than one pump is operating from the same source of supply.
6. A removable spool piece of a minimum of 0.30 m | 1 ft at the connection adjacent to the impeller is recommended to allow impeller alignment measurements during service activities.

Suction lift conditions

1. Suction pipe must be free from air pockets.
2. Suction piping must slope upwards to pump.
3. All joints must be airtight.

Suction head/Flooded suction conditions

1. An isolation valve should be installed in the suction line at least two pipe diameters from the suction to permit closing of the line for pump inspection and maintenance.
2. Keep suction pipe free from air pockets.
3. Piping should be level or slope gradually downward from the source of supply.
4. No portion of the piping should extend below pump suction flange.

5. The size of entrance from supply should be one or two sizes larger than the suction pipe.
6. The suction pipe must be adequately submerged below the liquid surface to prevent vortices and air entrainment at the supply.

Discharge piping

1. Isolation and check valves should be installed in discharge line. Locate the check valve between isolation valve and pump, this will permit inspection of the check valve. The isolation valve is required for priming, regulation of flow, and for inspection and maintenance of pump. The check valve prevents pump or seal damage due to reverse flow through the pump when the driver is turned off.
2. Increasesers, if used, should be placed between pump and check valves.
3. Cushioning devices should be used to protect the pump from surges and water hammer if quick-closing valves are installed in system.

Final piping check

1. Rotate shaft several times by hand to be sure that there is no binding and all parts are free.
2. Check alignment, per [Impeller alignment worksheet](#) (page 40) to determine absence of pipe strain. If pipe strain exists, correct the piping.

NOTICE: Prior to starting pump, ensure all flush and cooling systems are operating.

Drive Alignment Procedures

 Alignment procedures must be followed to prevent unintended contact of rotating parts. Follow coupling manufacturer's installation and operation procedures.



WARNING:

Before beginning any alignment procedure, make sure driver power is locked out. Failure to lock out driver power will result in serious physical injury. Lock out driver power to prevent electric shock, accidental start-up and physical injury.

The AF pump comes with two drive variations, V-belt and gear driven. Accurate alignment of both systems is essential to long pump life and reduced pump problems.

The points at which alignment are checked and adjusted are:

- **Initial Alignment** is done prior to operation when the pump and the driver are at ambient temperature.
- **Final Alignment** is done after operation when the pump and driver are at operating temperature.

Alignment is achieved by adding or removing shims from under the feet of the driver and gearbox and shifting equipment horizontally by adjusting bolts as needed.

NOTICE:

Proper alignment is the responsibility of the installer and user of the unit.

Trouble free operation can be accomplished by following these procedures.

Initial Alignment (Cold Alignment)

- **Before Grouting Sub-base** - To ensure alignment can be attained. **After Grouting Sub-base** - To ensure no changes have occurred during the mounting process.
- **After Spring Setting** – To ensure no changes have occurred during the leveling process.

After Connecting Piping - To ensure pipe strains have not altered alignment. If changes have occurred, alter piping to remove pipe strains on pump flanges.

- **Final Alignment (Hot Alignment)**

- After First Run - To obtain correct alignment when both pump and driver are at operating temperature. Thereafter, alignment should be checked periodically in accordance with plant operating procedures.

NOTICE:

Alignment check must be made if process temperature changes, piping changes, and or pump service is performed.

V-Belt Drive (Sheaves)

Well designed and properly installed V-belt drives are capable of running for years. AF pumps come in several different belt drive configurations i.e. side by side, overhead, underslung or "Z" mount. Installation and alignment procedures are similar for all configurations. Remove the guard or guards by referring to the assembly/disassembly instructions. There are a few items that should be checked during installation and alignment.

Sheave Alignment - Alignment must be maintained for full power transmission, minimum vibration, and long drive life. A dial indicator can be used to check runout on the periphery and face of each sheave. A straight edge can be used to check parallel and angular alignment of the pump and drive sheaves, see Figure: *Sheave alignment*.

Table 5: Sheave alignment

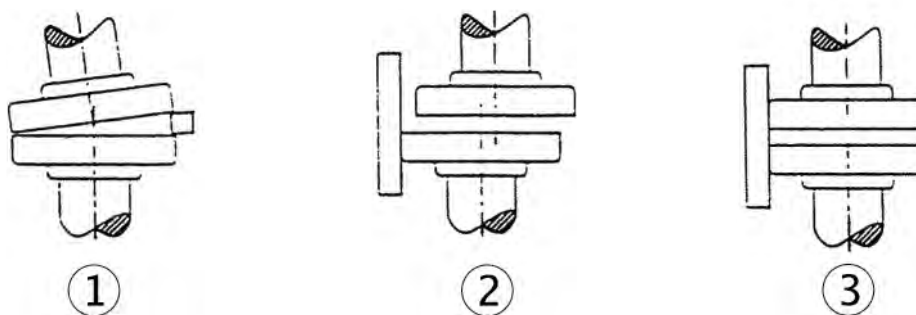

1. Parallel misalignment

2. Angular misalignment

3. Perfect alignment

1. **Belt Installation** - When installing new belts, shorten center distance between sheaves so that belts can be placed on the sheave without the use of force. Never 'roll' or 'Pry' the belts into place, as this could damage the belt cords.
2. **Check Belt Fit** - Regardless of the belt section used, the belt should never be allowed to bottom in the groove. This will cause the belts to lose their wedging action and slippage can occur. Sheaves or belts that permit such a condition to occur should be changed.
3. **Maintain Proper Belt Tension** - Proper tension is essential for long belt life. Improper tension could cause belt fatigue and/or hot bearings.
4. **Impeller Alignment after Belt Tensioning** - If the impeller was aligned prior to belt tensioning a check should be made to determine that it is still centered. An off center impeller may rub and cause unnecessary pump damage. Belt Tension will usually cause impeller misalignment opposite the motor. Be sure to align or re-align in accordance with the [Impeller Alignment](#) (page 34).

The general method of tensioning belts is given below, and should satisfy most drive requirements.

General Method:

1. Reduce the center distance so that the belts may be placed over the sheaves and in the grooves without forcing them over the sides of the grooves. Arrange the belts so that both belt spans have a proximately the same sag between the sheaves. Apply tension to the belts by increasing the center distance until the belts are snug, see Figure: *Belt tensioning*.

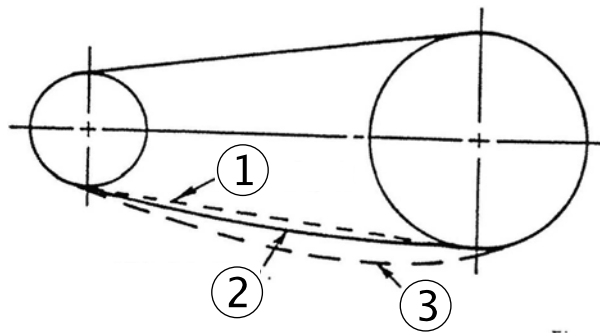

1. Too tight

2. Slight bow

3. Too loose

Figure 16: Belt tension



WARNING:

Do not operate the pump without the proper drive guard in place. Failure to observe this warning could result in personal injury to operating personnel

2. Operate the drive a few minutes to seat the belts in the sheave grooves. Observe the operation of the drive under its highest load condition (usually starting). A slight bowing of the slack side of the drive indicates proper tension. If the slack side remains taut during the peak load, the drive is too tight. Excessive bowing or slippage indicates insufficient tension. If the belts squeal as the motor begins operation or at some subsequent peak load, they are not tight enough to deliver the torque demanded by the drive machine. The drive should be stopped and the belts tightened.
3. Check the tension on a new drive frequently during the first day by observing the slack side span. After a few days of operation the belts will seat themselves in the sheave grooves and it may become necessary to readjust so that the drive again shows a slight bow in the slack side.
Other methods of determining proper belt tension can be obtained from the drive manufacturer.
4. **Use Belt Guards** - Belt guards protect personnel from danger and the drive from contamination. Inspect periodically to assure that belts do not rub against guard.
5. **Keep Belts Clean** - Dirt and grease reduce belt life. An occasional wiping with a dry cloth to remove any build-up of a foreign material can extend the life of the belt. Should oil or grease splatter onto the belts, clean with soap and water.

Belt dressing affects performance only temporarily and is never recommended. Maintaining a clean drive is a better practice.

If any questions arise pertaining to the drive limitations, consult the manufacturer.

Gear Drive (Couplings)

NOTICE:

 The coupling used in an ATEX classified environment must be properly certified.

Remove the guard or guards by referring to the assembly/disassembly instructions. Disconnect motor/gearbox and the pump/gearbox coupling halves before proceeding with the alignment. First, align the pump/gearbox coupling then the motor/gearbox coupling. Check both coupling connections for parallel and angular alignment by either the Dial Indicator or Straight-Edge Method outlined below. Good alignment is achieved when the dial indicator readings, for both parallel and angular misalignment, are 0.076mm | 0.003" Total Indicated Reading (T.I.R.) or less when the pump and driver are at operating temperature (Final Alignment). Figure: *Proper coupling alignment*, describes what to look for.

Table 6: Sheave alignment

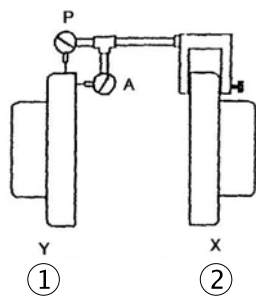
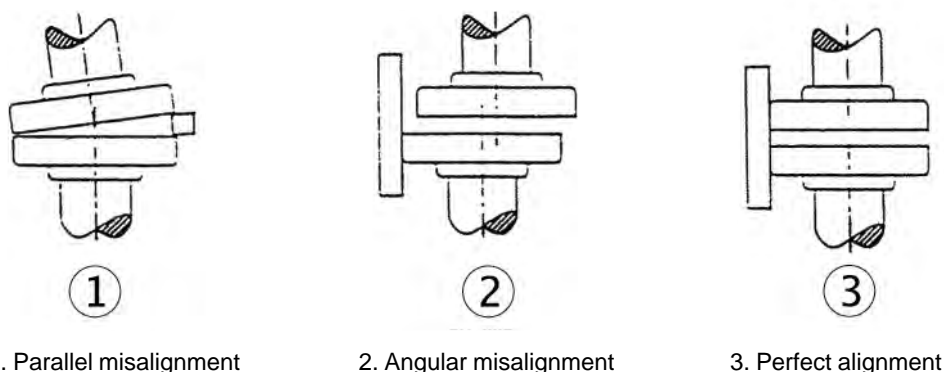

1. (Motor End) (Gear box end)
2. (Gearbox end) (Pump end)

Figure 17: Using a dial indicator to check coupling alignment

1. Mount two dial indicators off one half of the coupling (X) so they contact the other coupling half (Y).
2. Check setting of indicators by rotating coupling half (X) to ensure indicators stay in contact with coupling half (Y) but do not bottom out. Adjust indicators accordingly.
3. To ensure accuracy of indicator readings, always rotate both coupling halves together so indicators contact the same point on coupling half (Y). This will eliminate any measurement problems due to runout on coupling half (Y).
4. Take indicator measurements with hold-down bolts tightened. Loosen hold down bolts prior to making alignment corrections.
5. Take care not to damage indicators when moving driver during alignment corrections.

Keep this instruction manual handy for reference. Further information can be obtained by contacting Goulds Pumps, 240 Fall St., Seneca Falls, New York 13148 or your local representative.

Alignment Procedure

On gear driven AF pumps angular and parallel misalignment are corrected in the vertical direction by means of shims under the motor or gearbox mounting feet, and in the horizontal direction by adjusting bolts that slide the motor or gearbox in the proper direction. After each adjustment, it is necessary to recheck the alignment of the coupling halves. Adjustment in one direction may disturb adjustments already made in another direction. It should not be necessary to adjust the pump in any way.

Angular Alignments

Couplings are in angular alignment when indicator "A" (Angular Indicator), (refer to Figure: *Proper coupling alignment*) does not vary by more than 0.076mm | 0.003" as measured at four points on the coupling periphery 90° apart at operating temperature. Outlined below are two acceptable methods to achieve the desired alignment.

METHOD 1 - Dial Indicator Method

For steps 1 through 5 refer to Figure: *Directions for viewing coupling (view from front end of pump)*.

1. Zero indicator "A" at position 1 of coupling half (Y). Mark this position on both flanges.
2. Rotate both flanges 180° to position 3. Observe needle and record reading.
3. Negative Reading - The coupling halves are further apart at position 3 than position 1.
Positive Reading - The coupling halves are closer at position 3 than position 1.

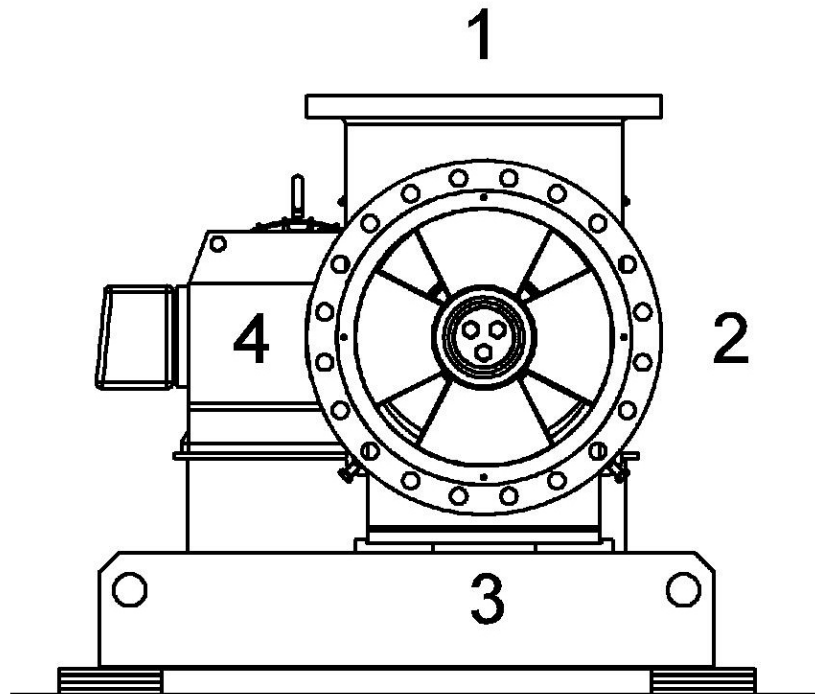

Figure 18: Directions for viewing coupling (view from front end of pump)

4. Correct any misalignment by shimming the under the motor or gearbox feet to attain the proper alignment.
When using positions 2 and 4 in steps 1-3, correct any misalignment by sliding the motor back and forth to attain the proper alignment.
5. Repeat steps 1-4 substituting position 2 for position 1 and position 4 for position 3. Use the same marks made on the coupling from position 1 and be sure to turn the coupling halves together.

METHOD 2 - Feeler Gauge Method

For the following steps refer to Figure: *Directions for viewing coupling (view from front end of pump)*.

1. Insert a feeler gauge at position 1 at the periphery of the couplings. Mark this position on both flanges.
2. Record the largest gauge size that fits snugly between the two flanges.
3. Rotate both flanges to position 3 - 180°
4. Insert a feeler gauge at the periphery of the couplings at position 3.
5. Record the largest gauge size that fits snugly between the two flanges.
6. Calculate the difference between the readings at positions 1 and 3. The difference should not be greater than 0.076mm | 0.003".
7. Correct any misalignment by shimming under the motor or gearbox feet to attain the proper alignment.
When using positions 2 and 4 in steps 1 - 6, correct any misalignment by sliding the motor or gearbox back and forth to attain the proper alignment.
8. Repeat steps 1-6 substituting positions 2 and 4 for position 1 and 3 respectively. Use the same marks made on the coupling from position 1 and be sure to turn the coupling halves together.

Parallel Alignment

The unit is in parallel alignment when indicator "P" (Parallel Indicator) does not vary by more than 0.076mm | 0.003" as measured at four points on the coupling periphery 90° apart at operating temperature. There are two methods outlined below that are acceptable to achieve the desired alignment.

NOTICE: Equal amounts of shims must be added to or removed from each driver foot. Otherwise the vertical angular alignment will be affected.

METHOD 1 - Dial Indicator Method

For the following steps, refer to Figure: *Directions for viewing coupling (view from front end of pump)*.

1. Zero the indicator "P" at position 1 of coupling half (Y). Mark this position on both flanges.
2. Rotate both flanges 180° to position 3. Observe needle and record reading.
3. Negative Reading - Coupling half (Y) is shifted toward position 1.
If the value is greater than 0.076mm | 0.003", correct the misalignment by evenly (at equal amounts on both sides) shimming the motor higher. When using positions 2 and 4 in steps 1 - 2, correct any misalignment by sliding the motor evenly toward position 2.
Positive Reading - Coupling half (Y) is shifted toward position 3.
If the value is greater than 0.076mm | 0.003", correct the misalignment by evenly (at equal amounts on both sides) shimming the motor or gearbox lower. When using positions 2 and 4 in steps 1 - 2, correct any misalignment by sliding the motor or gearbox evenly toward position 4.
4. Repeat steps 1-3 until indicator "P" reads 0.076mm | 0.003" or less.
5. Once the ideal alignment is reached, repeat steps 1-4 substituting position 2 for position 1 and position 4 for position 3.

METHOD 2 - Straight-Edge Method

For the following steps refer to Figure: *Directions for viewing coupling (view from front end of pump)*.

1. Place a straight edge across the two coupling flanges at position 1 and mark the spot on both flanges.
2. Adjust the motor or gearbox so that the straight-edge rests evenly on both flanges (within 0.076mm | 0.003").
3. Rotate both flanges 90° to positions 2 and repeat steps one and two.
4. The unit will be in parallel alignment when the straight edge rests evenly (within 0.076mm | 0.003") on the coupling periphery at both positions along the periphery.

NOTICE: Care must be taken to have the straight edge parallel to the axis of the shafts

Complete Alignment

A unit is in complete alignment when both indicators "A" (angular) and "P" (parallel) do not vary by more than 0.076mm | 0.003" as measured at four points 90° apart.

Vertical Correction (Top-to-Bottom)

1. Zero indicators "A" and "P" at top dead center (12 o'clock) of coupling half (Y).
2. Rotate indicator to bottom dead center (6 o'clock). Observe the needles and record the readings.
3. Make corrections as outlined previously.

Horizontal Correction (Side-to-Side)

1. Zero indicators "A" and "P" on the left side of coupling half (Y), 90° from top dead center (9 o'clock).
2. Rotate indicators through, top dead center to the right side, 180° from the start (3 o'clock), Observe the needle, measure and record the reading.
3. Make corrections as outlined previously.
4. Recheck both vertical and horizontal readings to ensure adjustment of one did not disturb the other. Correct as necessary.

Factors that may disturb alignment

The unit should be checked periodically for alignment. If the unit does not stay in line after being properly installed, the following are possible causes:

1. Settling or spring of the foundation.
2. Wear of bearings.
3. Pipe strains distorting or shifting the machine.
4. Shifting of the sub-base due to heat created from an adjacent heat source.
5. Shifting of the building structure due to variable loading or other causes.
6. Loose nuts or bolts on the pump or driver assembly.

NOTICE: With experience, the installer will understand the interaction between angular and parallel and will make corrections appropriately.

Impeller Alignment

 Improper impeller adjustment could cause contact between the rotating and stationary parts, resulting in a spark and heat generation.

 The impeller clearance setting procedure must be followed. Improperly setting the clearance or not following any of the proper procedures can result in sparks, unexpected heat generation and equipment damage.

The AF impeller has been aligned at the factory but should be checked prior to pump operation. The impeller requires several thousandths of an inch of clearance to prevent rubbing due to the action of hydraulic forces when the pump is operating. Many corrosion-resistant alloys will gall and build up if rubbing occurs, therefore, pumps using these alloys need to be free from any rubbing.

Turn the shaft by hand, if the impeller rubs the inside of the casing it must be realigned. The following steps are used to align the impeller.

There are (3) types of impeller adjustment for the AF pump. Type 1 has adjusting lugs on the stuffing box cover, Type 2 and 3 have adjusting lugs on the elbow. Type 1 moves the back-pullout relative to the elbow. Type 2 moves the casing relative to the impeller. Type 3 (Fabricated non-backpullout only) moves the power frame relative to the elbow to set the clearance (see figures for type 1, 2, and 3 adjustment).

NOTICE: Impeller rubbing is often caused by pipe strain or belt tension. Pipe strain must be eliminated prior to impeller alignment. The impeller should be aligned after proper belt tensioning.

Clearance measurement

The alignment worksheet Figure: *Impeller alignment worksheet*, is used to align the impeller of the AF pump. The measurement procedure is as follows:

Make sure the cap screws fastening the casing to the elbow are tight (if applicable), so an accurate measurement of the impeller clearances can be made prior to adjustment.

Mark each blade 1, 2, 3 and 4 and then align the impeller blades as shown on the impeller alignment worksheet (approx. 2, 4, 8, and 10 o'clock).

Rotate the shaft and measure the gap between each blade and the casing at all four clock positions indicated on the worksheet. The value of interest is the largest value of feeler gauge thickness that will slide easily the whole length of the vane tip.

Add the measurements for all positions together and divide by the number of measurements. This will give the average measurement.

Divide the average measurement by 2. This will give the minimum clearance.

If any blade has a clearance in any position smaller than the calculated minimum clearance the prop is not sufficiently centered and should be adjusted.

Align the impeller (Type 1)

1. Loosen the bolts that attach the bearing housing to the elbow.
2. Use the adjusting bolts closest to the elbow to adjust the impeller clearance.
The (2) upper adjusting bolts are used to raise and lower the impeller. The upper and lower adjusting bolts on either side are used to center the impeller left to right in the elbow.

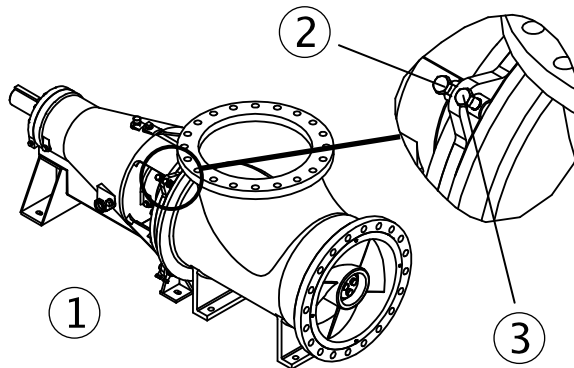

1. Type adjustment
2. Box alignment
3. Impeller alignment

Figure 19: Type 1 adjustment

3. Move the back pullout relative to the elbow until the impeller is centered.
At this point it is recommended that the Impeller Alignment Worksheet be filled out and filed with the pump maintenance records for future reference.
4. Tighten the bolts between the bearing housing and elbow and re-check the clearance to be sure the adjustments have centered the impeller.
If the impeller is centered the bearing housing may be taper pinned to the elbow to maintain alignment.

Align the impeller (Type 2)

1. Loosen the bolts that attach the casing to the elbow.
2. Use the adjusting bolts attached to the elbow to adjust the impeller clearance.
The (2) adjusting bolts are used to raise and lower the casing and shift the casing left to right relative to the impeller.

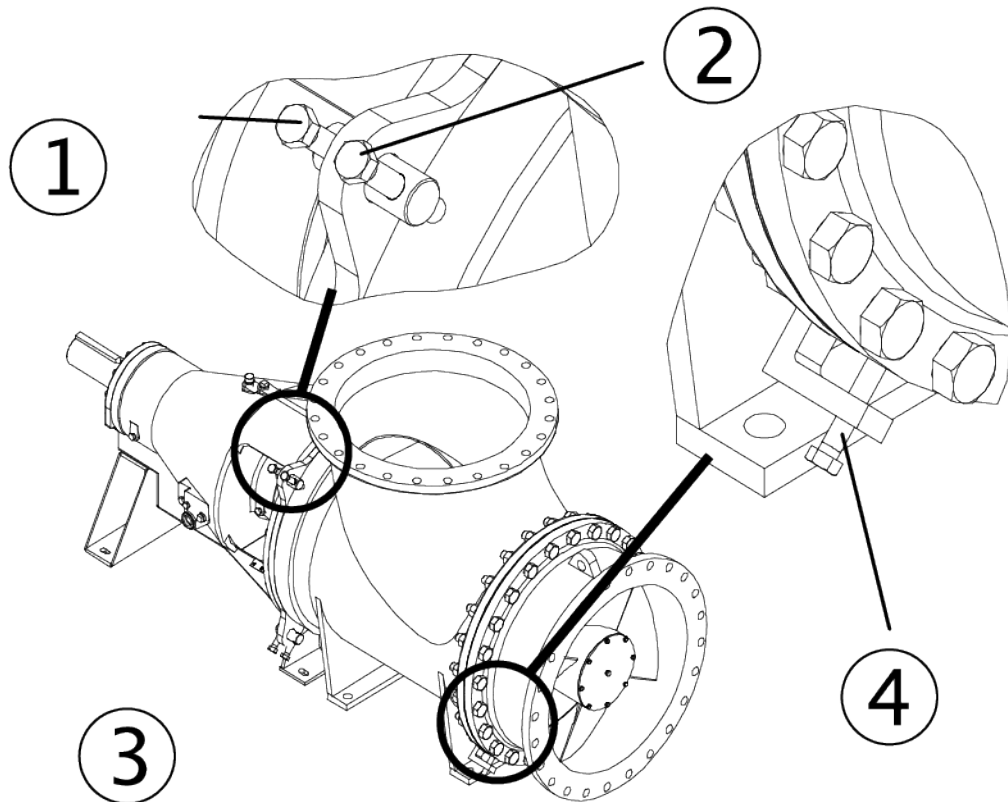

1. Box alignment
2. Not used
3. Type 2 adjustment
4. Impeller alignment

Figure 20: Type two impeller alignment

3. Move the casing relative to the impeller until the impeller is centered. At this point it is recommended that the Impeller Alignment Worksheet should be filled out and filed with the pump maintenance records for future reference.
4. Tighten the bolts between the casing and the elbow and re-check the clearance to be sure the adjustments have centered the impeller. If the impeller is centered the casing may be taper pinned to the elbow to maintain alignment.

Align the Impeller and Packing/Mechanical Seal (Type 3)

1. Loosen the bolts (356E & 7990) and nuts (357A) that attach the power end to the elbow (315A).
2. Using the impeller adjusting bolts (356A), adjust the impeller clearance. The adjusting bolts are used to move the power end and impeller (101) relative to the elbow.
3. Move the impeller relative to the elbow until the impeller is centered. At this point, it is recommended that the Impeller Alignment Worksheet should be filled out and filed with the pump maintenance records for future reference.
4. Tighten the bolts and nuts between the power end and the elbow and re-check the clearance to be sure the adjustments have centered the impeller. If the impeller is centered, the bearing housing may be taper pinned to the elbow to maintain the alignment.

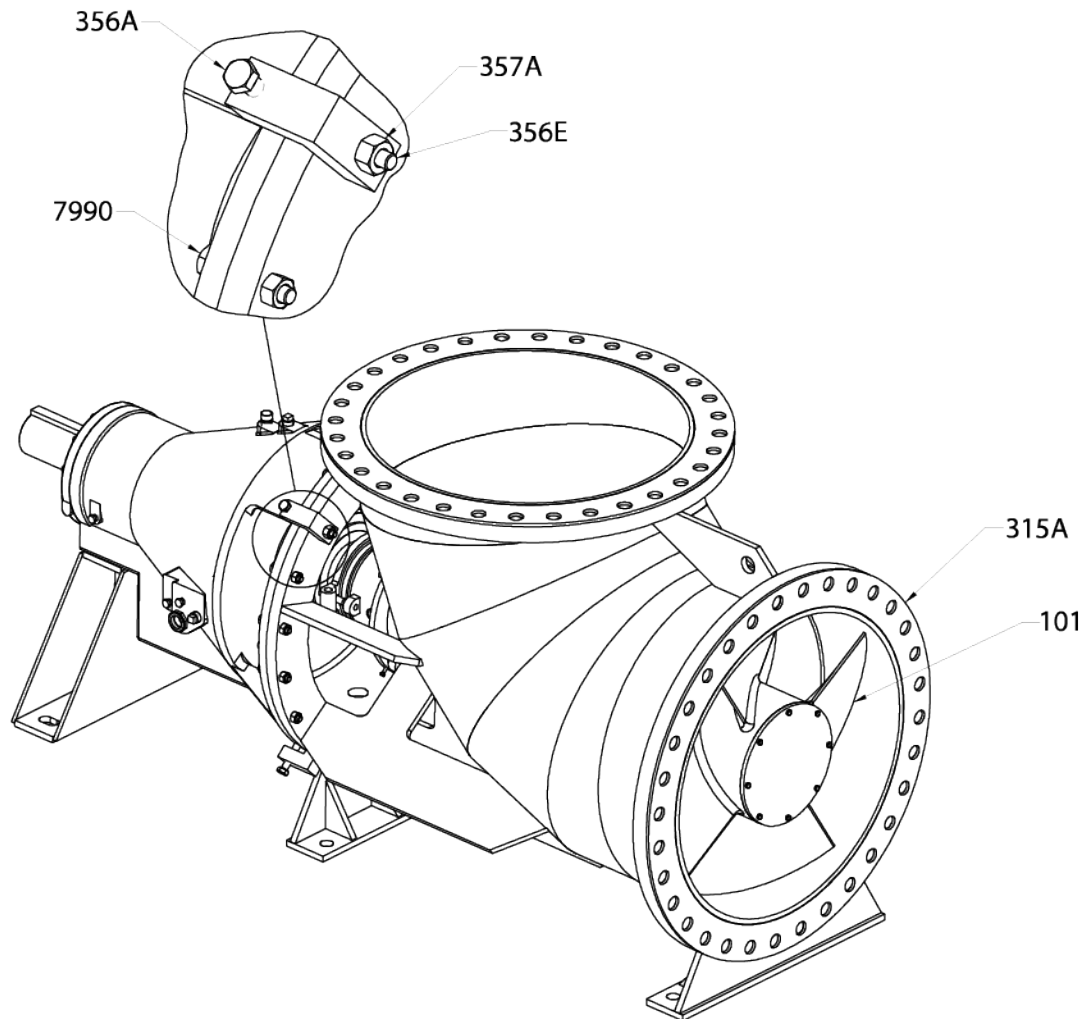

Figure 21: Type 3 impeller alignment

If the pump was supplied with packing, next align the packing chamber (Type 3)

1. Loosen the nuts (425) on the studs (799E) that attach the packing chamber (220) to the elbow (315A).
2. Using the packing chamber adjusting screws (341C), move the packing chamber relative to the shaft sleeve (126), until the shaft sleeve is centered inside the packing chamber.
3. Tighten the nuts on the studs that attach the packing chamber to the elbow.
4. Pack the packing chamber initially with two rings of packing (106), staggering the joints for each row.

5. Insert the lantern ring (105), being sure that the lantern ring lines up with the flush ports. If the lantern ring has taps for removal, make sure they face out of the chamber.
6. Insert three more rings of packing (106), staggering the joints for each row.
7. Insert the gland studs (353) into the packing chamber.
8. Insert the packing gland (107) into the packing chamber.
9. Install the gland nuts (355) and tighten.
10. Install any necessary flush tubing.

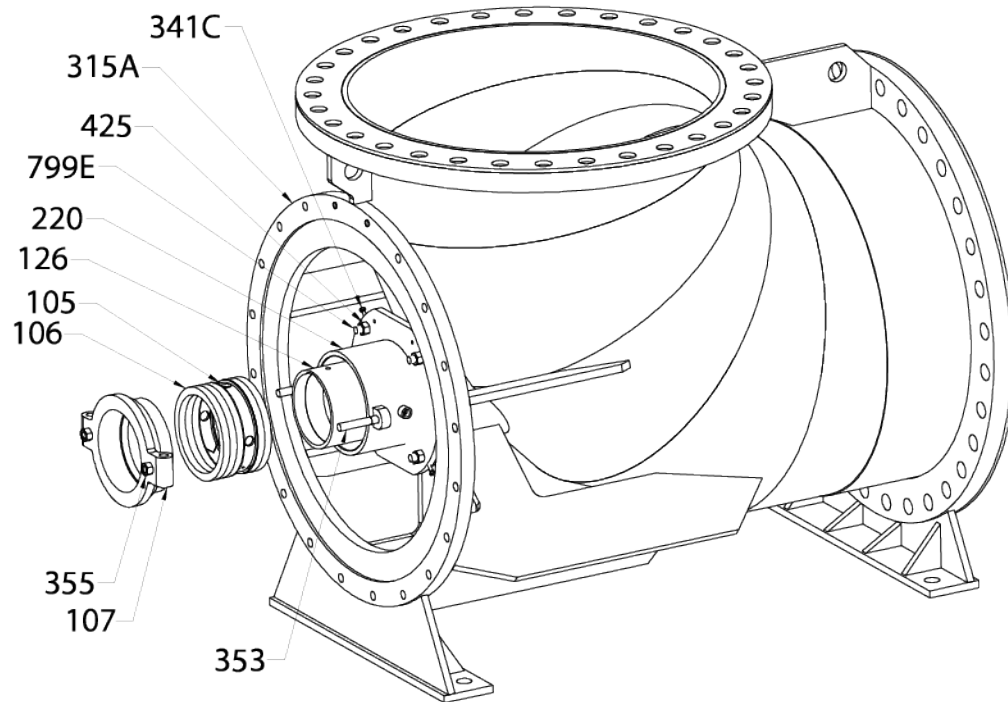

Figure 22: Packing chamber alignment and installation of packing gland and hardware

If the pump was supplied with a mechanical seal, next align the mechanical seal adapter (Type 3)

1. Loosen the nuts (355) on the gland studs (353) that attach the mechanical seal (383) and mechanical seal adapter (108D) to the elbow (315A).
2. Slide the mechanical seal back from the mechanical seal adapter to gain access to the mechanical seal adapter.
3. Loosen the socket head cap screws (370) that attach the mechanical seal adapter to the elbow.
4. Using the adjusting bolts (341C) in the mechanical seal adapter, move the mechanical seal adapter relative to the shaft (122), until the shaft is centered inside the mechanical seal adapter.
5. Tighten the socket head cap screws that attach the mechanical seal adapter to the elbow.
6. Slide the mechanical seal back to the mechanical seal adapter.
7. Tighten the nuts on the gland studs to attach the mechanical seal to the mechanical seal adapter. Refer to the mechanical seal manufacturer's instructions for specific instructions on the installation of the mechanical seal.

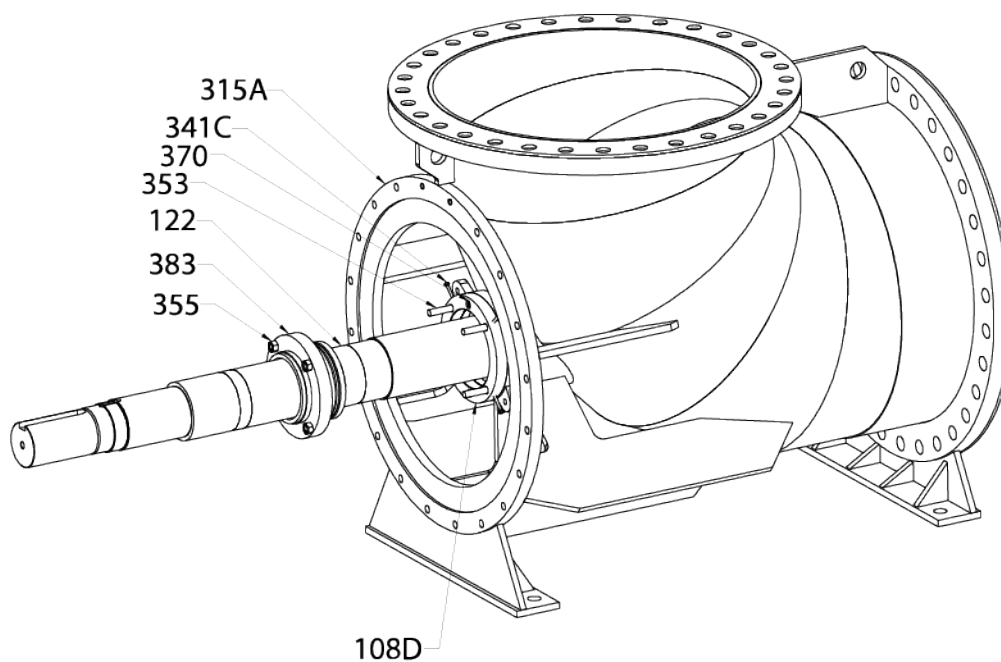



Figure 23: Alignment of mechanical seal adapter and installation of mechanical seal and hardware

Rotation Check

Before the V-belts or couplings are installed, the motor should be wired and the direction of rotation checked. A rotation arrow is located on the bearing housing (134C).

Serious damage could occur if the pump is run the wrong direction.

NOTICE:

 When installing in a potentially explosive environment, make sure that the motor is properly certified.

Impeller alignment worksheet

INSTALLATION AND OPERATING INSTRUCTIONS

AXIAL FLOW PUMP IMPELLER ALIGNMENT WORKSHEET 4 VANE IMPELLER

PUMP SERIAL NO.: _____ DATE: _____

PUMP SIZE: _____ PUMP ALIGNED BY: _____

10 O'CLOCK

VANE 1 _____
 VANE 2 _____
 VANE 3 _____
 # VANE 4 _____

2 O'CLOCK

VANE 1 _____
 VANE 2 _____
 VANE 3 _____
 # VANE 4 _____

8 O'CLOCK

VANE 1 _____
 VANE 2 _____
 VANE 3 _____
 # VANE 4 _____

4 O'CLOCK

VANE 1 _____
 VANE 2 _____
 VANE 3 _____
 # VANE 4 _____

Impeller Alignment - The measurement procedure is as follows:

1. Note the number of blades. Mark each blade 1, 2, 3, 4.
2. Rotate the shaft and measure the gap between each blade and the casing at the 2, 4, 8, and 10 o'clock positions. The value of interest is the largest value of feeler gage thickness that will slide easily the whole length of the vane tip.
3. Add the measurements for all positions together and divide by the number of measurements. This will give the average measurement.
4. Divide the average measurement by 2. This will give the minimum clearance.
5. If any blade has a clearance in any of the positions that is smaller than the calculated minimum clearance the prop is not sufficiently centered and should be adjusted.

Example: 4 Vane impeller. At 2 o'clock the readings are VANE 1-.040, VANE 2-.041, VANE 3-.040, VANE 4-.042; at 4 o'clock .050,.051,.050,.051; at 8 o'clock .050,.052,.051,.050; at 10 o'clock .040,.042,.039,.041

Average clearance = $\frac{\text{SUM OF READINGS}}{\text{NUMBER OF READINGS}} = \frac{.040+.041+.040+.042+ \dots}{16} = .0456"$

Minimum clearance = $\frac{\text{AVERAGE CLEARANCE}}{2} = \frac{.0456"}{2} = .0228"$

Commissioning, Startup, Operation, and Shutdown

Preparation for start-up

NOTICE:

 When installing in a potentially explosive environment, ensure that the motor is properly certified.

 Damage occurs from:

Checking rotation

1. Increased vibration levels-affects bearings, stuffing box or seal chamber and mechanical seal
2. Increased radial loads Stresses on shaft and bearings
3. Heat build up-Vaporization causing rotating parts to score or seize
4. Cavitation-Damage to internal surfaces of pump



CAUTION:

Serious damage may result if pump is run in the wrong direction.



WARNING:

Lock out power to prevent accidental start-up and physical injury.

A check must be made to be sure motor rotation coincides with the pump rotation direction. Depending on your pump arrangement (V-belt or gear-drive) use one of the following methods to check motor rotation.

Direct connect

1. Lock out power to the driver.
2. Remove the pump coupling guard.
3. Make sure the coupling halves are securely fastened to shafts.
4. Unlock driver power.
5. Make sure everyone is clear. Jog the driver just long enough to determine direction of rotation of the output shaft of the gearbox. Rotation must correspond to an arrow on bearing housing.
6. Lock out power to driver.
7. Replace the pump coupling guard.

NOTICE:

 The coupling guard used in an ATEX classified environment must be constructed from a non-sparking material.

V-Belt

1. Lock out power to the driver.
2. Remove the V-belt guard.
3. Make sure the sheaves are securely fastened to shafts.

4. Unlock driver power.
5. Make sure everyone is clear. Jog the driver just long enough to determine direction of rotation. Rotation must correspond to an arrow on bearing housing.
6. Lock out power to driver.
7. Replace the V-belt guard.

Check Impeller Clearance

Check impeller clearance before installing the pump. The impeller must not rub when the shaft is turned by hand, therefore it is recommended that the [Impeller alignment worksheet](#) (page 40) is filled out and filed with the pump maintenance records for future reference.

Check for free turning

Before the pump is started, rotate the pump by hand to be sure it turns freely, and does not rub or bind.

Bearings

The bearing assembly uses spherical roller or ball bearings to carry the radial load, and angular contact ball or tapered roller thrust bearing to carry the axial thrust load from the impeller. The bearing housing has a horizontal split along the centerline for ease of assembly and inspection.

Bearing lubrication

Before start up, the pump should be checked for proper lubrication. AF pumps are flood-oil or grease lubricated. Lubrication method is usually dependent on the pump operating conditions. The following paragraphs describe both methods of lubrication.

Flood oil



WARNING: Bearings must be lubricated properly in order to prevent excess heat generation, sparks and premature failure.

Oil lubricated bearings use an oil bath for lubrication. Oil lubricated bearing assemblies are shipped without oil. **ADD OIL TO THE HOUSING UNTIL IT IS AT THE CENTERLINE OF THE SIGHT GLASS.** Oil must be added to the bearing housing before starting. If the unit has an external oil lube system, fill the bearing housing and the reservoir to satisfy the system requirements.

Run the pump for 1 minute to fill the oil galleys and in and around each bearing. Check the oil level indicator and add oil accordingly. Monitor the oil level indicator for the first 24 hours of operation and maintain fill level.

Change the oil after the first 200 hours of operation. For normal operating conditions, change the oil at least four (4) times a year. If the bearing assembly is exposed to dirty or moist conditions, the oil should be changed more often.

If the level of oil in the bearing housing (134C) is too high, excessive heat may be generated due to churning. If the level is too low, excessive heat may be generated due to inadequate lubrication. A liquid level switch connected to the oil sump can be used to warn of a dangerous oil level condition.

Observe the oil level requirements shown on the assembly drawing furnished with the pump. If excessive heat is experienced within these levels, consult the factory. Be sure that the shaft centerline is horizontal through the bearing housing.

Grease

Bearings are hand-packed at the factory and have sufficient grease for at least 24 hours of operation after startup. The bearings will run hotter than normal for the first few hours until the grease is worked out of the ball path and the bearings have "run- in". Adding more grease during this period may increase the bearing temperature. After the first re-greasing, a small amount of grease should be added at each fitting every 500 hours of operation or 3 weeks of continuous operation.

Oil Type

Use an industrial quality lubrication oil such as Mobil DTE series, Exxon Teresstic, or similar of ISO VG68. ISO VG46 may be used in ambient temperatures below 4°C | 40°F .

In any case the operating temperature viscosity must be a minimum of 150SSU.

An oil with a higher viscosity than required will increase the bearing operating temperature because of the extra viscous drag, but never to the point where the viscosity becomes lower than required from the increased heat generation. It is therefore better for the bearings to have an oil that is too heavy rather than too light.

Change the oil after the first 200 hours of operation. For normal operating conditions, change the oil at least four (4) times a year. If the bearing assembly is exposed to dirty or moist conditions, the oil should be changed more often.

Oil level control

If the level of oil in the bearing housing (134C) is too high, excessive heat may be generated due to churning. If the level is too low, excessive heat may be generated due to inadequate lubrication. A liquid level switch connected to the oil sump can be used to warn of a dangerous oil level condition.

Observe the oil level requirements shown on the assembly drawing furnished with the pump. If excessive heat is experienced within these levels, consult the factory. Be sure that the shaft centerline is horizontal through the bearing housing

Normal bearing temperature

The running temperature for a bearing assembly depends on many factors such as speed, bearing loads, lubrication, ambient air temperatures, and condition of bearings. Temperatures higher than the human hand can tolerate are very satisfactory for temperature and should not be cause for alarm. Sudden change in temperature without any change in speed or loading can mean a lubrication difficulty or the approach of bearing failure.

Temperatures higher than the human hand can tolerate are very satisfactory for good bearing operation and should not cause any alarm.

For a given speed and loading, the bearing housing temperature will stabilize at some temperature, usually below 93°C | 200°F, which will be the normal temperature for the installation. Higher temperatures than this normal temperature, without any change in speed or loading can mean a lubrication difficulty or the approach of bearing failure.

Installing bearing

Long bearing life is dependent on careful handling of the bearing when it is out of the housing and during the installation procedure. Dirt and rough handling are prime enemies of precision bearings. Bearings should be pressed, not "hammered" into place. If heat is used to facilitate the installation, a hot oil bath is the best method.



CAUTION:

Wear insulated gloves when you use a bearing heater. Bearings get hot and can cause physical injury.

Thrust bearing orientation

All 6" thru 36" AF pumps use a bidirectional thrust bearing arrangement capable of taking all thrust loads in either direction for either top or end suction configuration. See [Bearing alignment](#) (page 121) for the correct bearing installation. Pump Description table in [Pump Description](#) (page), shows sizes vs. bearing arrangement style utilized.

Shaft sealing

A packed stuffing box or mechanical seal is used to seal the AF pump shaft. Both methods are described below.

Packed stuffing box

The original equipment packing is a suitable grade for the service intended. To pack the standard stuffing box use the following procedure: For the special (6) ring packing arrangement see [Bearing alignment](#) (page 121) Appendix 1.

1. Stuffing box and shaft sleeve must be clean and free of grit.
For a given speed and loading, the bearing housing temperature will stabilize at some temperature, usually below 93°C | 200°F, which will be the normal temperature for the installation.
2. Form packing over shaft or mandrel of same diameter. Carefully cut to packing length. Discard rings cut too short.
3. Pre-form each ring by coiling 1-1/2 turns.
4. To install packing rings, do not pull straight. Expand the coil as a coil spring, see Figure: *Packing rings*, for the correct and incorrect method of installing packing.

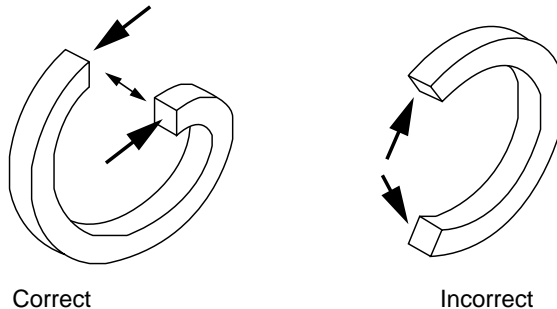

Figure 24: Packing rings

Expand the first coil as shown and insert into stuffing box. Tamp packing to stuffing box shoulder firmly with the gland. Note, where the cut is positioned.

5. Install the first lantern ring into the stuffing box. Failure to properly locate the lantern ring with the flush port will result in insufficient packing lubrication.
6. Install the second and third coil as required by sectional drawing, staggering the cut 90° to 120°.
7. Install the second lantern ring into stuffing box, carefully noting its proper position on the sectional drawing.
8. Install the third and fourth coil as required by sectional drawing, staggering the cut 90° to 120°.
9. After packing and lantern rings are properly installed, insert gland into stuffing box. Tighten gland nuts finger tight only. The shaft should turn freely.
10. Turn lubricant supply on, start pump, and adjust the gland as described in Section III-E Stuffing Box Adjustment.
11. Periodic maintenance is absolutely required for all packed pumps. Normal shaft run-out should be under 0.13mm | 0.005" to avoid pounding of stuffing box packing. With excessive shaft run-out, shaft straightening or replacement is necessary.

Gland adjustment

Adjust the stuffing box if packing is used. When the pump is first started, there should be considerable leakage by the gland to cool the packing. Gradually tighten the gland nuts on flat at a time while observing the leakage and stuffing box temperature. Packing requires time to "run-in" and extra coolant (leakage) while it is being "run-in". If the leakage is reduced too quickly, the packing will overheat and may be destroyed. The shaft sleeve may also be damaged.

Leakage

Normal leakage for a properly adjusted box, depending on shaft size and speed, varies from a few drops a second to a small trickle out of the gland.

Mechanical seal

The mechanical seal used in an ATEX classified environment must be properly certified.

 The mechanical seal must always be properly flushed. Failure to do so will result in excess heat generation and seal failure

Most mechanical seals are installed and adjusted at the factory. A common seal type used on the AF pump is the cartridge type. Cartridge seals are preset at the seal manufacturer's facility and require no field settings. Due to size and design, some installed mechanical seals are supplied with holding clips. These clips keep the sealing faces apart to avoid damage during transport. The clips must be removed before the shaft is to be rotated. Pumps with retained seal faces will be specifically marked and instructions from the seal manufacturer for clip removal will be provided.

If the seal has been installed in the pump at the Goulds Pumps factory, these clips have already been removed. For other types of mechanical seals, refer to the seal manufacturer's instructions for installation and setting.

Mechanical seals have a stationary and a rotating sealing face. Commonly, these sealing rings are of carbon and ceramic material, brittle in nature, and easily damaged. As the sealing rings seat with the operation of the pump, a compatible wear pattern develops between the mating surfaces.

To disassemble the mechanical seal after the wear pattern is established would necessitate the replacement of the rotating element and stationary sealing elements. Do not replace only one component.

To ensure the life and sealing characteristics of the mechanical seal, lubricating liquid must be circulated through the seal gland. Clear, grit-free liquid is necessary. Goulds Pumps strongly recommends the stocking of replacement sealing elements.



WARNING:

Do not make shaft adjustments on mechanical seal installations without consulting seal instructions and the pump assembly drawing. Damage to the mechanical seal may result.

Start the Pump

Priming the pump

 Pumps that are not self-priming must be fully primed at all times during operation.



DANGER:

All openings (e.g. pipe connections, flanges) must be sealed off with proper fitting and material prior to filling pump. Failure to plug all openings will result in personal injury.



WARNING:

Foreign objects in the pumped liquid or piping system can block the flow and cause excess heat generation, sparks and premature failure. Make sure that the pump and systems are free of foreign objects before and during operation.



WARNING:

If pump becomes plugged, shut down pump and unplug prior to restarting.

**CAUTION:**

1. Foreign objects in the pumped liquid or piping system can block the flow and cause excess heat generation, sparks and premature failure. Make sure that the pump and systems are free of foreign objects before and during operation.
2. All equipment and personal safety related devices and controls must be installed and operating properly.
3. To prevent premature pump failure at initial start up due to dirt or debris in the pipe system, ensure the system has been adequately cleaned and flushed.
4. Variable speed drivers should be brought to rated speed as quickly as possible.
5. Variable speed drivers should not be adjusted or checked for speed governor or overspeed trip settings while coupled to the pump at initial start up. If settings have not been verified, uncouple the unit and refer to driver manufacturers instructions for assistance.
6. Pumpage temperatures in excess of 93°C | 200°F will require warmup of pump prior to operation. Circulate a small amount of pumpage through the pump until the casing temperature is within 38°C | 100°F of the pumpage temperature and evenly heated.
 ⚠ When starting pump, immediately observe pressure gauges. If discharge pressure is not quickly attained, stop driver, re-prime and attempt to restart.
7. Never start the pump until it has been properly primed. Check the pump impeller for submergence. The pump must be full of liquid with specified submergence head above the impeller. Do not run the pump dry, as this might damage pump and seal components.
8. Lubricating liquid must be flowing to the stuffing box before pump is started.

Flush flows

Prior to starting pump, ensure all flush and cooling systems are operating.

Packing or mechanical seals are used to seal the rotating shaft. Generally, a clear liquid such as water is used to lubricate and cool the sealing elements. The lubricating liquid pressure must be 10 -15 psi higher than the pressure inside the elbow to prevent pumpage from entering the sealing elements. The lubricating liquid must be clean and free of grit. Shaft scoring, packing destruction, and mechanical seal face damage will result from contaminated lubricant. The stuffing box may be on the suction or the discharge side of the impeller, depending on the direction of flow through the elbow ordered by the customer. If the pressure inside the elbow is unknown, it should be measured with a pressure gauge when the pump is operating. The standard stuffing box is furnished with (1) N.P.T. holes for piping the lubricating liquid. The lubricating liquid is piped into it. Some users simply plug the other hole. For additional cooling of the sealing elements, an outlet pipe with a valve can be installed to allow more liquid to flow through the stuffing box.

For special (6) row packing arrangement see appendix 1 at the end of this manual for flush pressures and flow rates.

(Mechanical seals have no leakage and usually require a lubricant flow through the stuffing box for cooling). The lubricating flow should be regulated by the valve in the outlet pipe rather than by throttling the flow in the supply pipe.

Driver

Start driver.

**CAUTION:**

Immediately observe the pressure gauges. If discharge pressure is not quickly attained, stop the driver, reprime, and attempt to restart the pump.

Set desired flow

If your system is equipped with a variable frequency drive (VFD) or a variable speed V-belt drive, you may at this point want to set your speed for the desired flow.

**CAUTION:**

Observe the pump for vibration levels, bearing temperature, and excessive noise. If normal levels are exceeded, shut down the pump and resolve the issue.

Operation

General considerations

 Service temperature in an ATEX classified environment is limited by the table in the ATEX identification section.

1. Do not operate pump below hydraulic minimum flow. For hydraulic minimum flow, refer to technical manual and pump performance curve.
2. Do not operate pump below hydraulic or thermal minimum flow. For hydraulic minimum flows refer to technical manual and pump performance curves. To calculate thermal minimum flow, refer to HI Centrifugal Pump Design and Application ANSI/HI 1.3-2000.
3. Do not operate pump past maximum flow. For maximum flow refer to pump performance curve.
4. Observe the pump for vibration levels, bearing temperature, and excessive noise. If normal levels are exceeded, shut down the pump and resolve the issue.
5. Make sure to operate the pump at or near the rated conditions. Failure to do so can result in pump damage from cavitation or recirculation.
6. Vary the capacity with the regulating valve in the discharge line. Never throttle the flow from the suction side since this can result in decreased performance, unexpected heat generation, and equipment damage.
7. Net positive suction head available (NPSH_A) must always exceed NPSH required (NPSH_R) as shown on the published performance curve of the pump.
8. NPSH_A must always exceed NPSH_r as shown on Goulds performane curves received with order.
9. Reference Hydraulic Institute for NPSH and pipe friction values needed to evaluate suction piping.
10. Most axial flow pumps are in evaporator circulation service and since the evaporator performance and the amount of product depends on the rate of liquid circulation, care should be taken to maintain these pumps in good operating condition.
When production drops off, it is usually due to lower circulation rate. An approximation of this rate can be made by several methods:
 1. Temperature drop across the heat exchanger.
 2. Visual inspection of flow in evaporator body.
 3. Testing the circulating pump.
11. Items (1) and (2) above are covered by the system designer.
12. While field conditions preclude absolute accuracy, a check of pump performance will give reasonably close results. This can be done by installing a mercury manometer at pipe taps located at least-one pipe diameter away from the suction and discharge flanges of the pump. If-gauges are used, the pressure differential times 2.31 divided by the specific gravity of the slurry indicates the TDH against which the pump is actually operating. If a manometer is used, then inches of mercury times 1.0455 divided by specific gravity equals TDH, providing water is in both legs of the manometer and connecting lines.
13. Check the pump speed and determine flow rate (gpm) from the pump curve. This curve will also give efficiency from which the hp requirement can be determined. A double check is to take motor ammeter readings, convert to hp, figure 90% drive efficiency, and use it against the pump curve to get GPM. This is only an approximate check, as the hp curve on some applications is rather flat, but is probably within 7-1/2%. It is important to take and record these readings when the equipment is new, so that later readings can be judged on a relative basis.

Operating at reduced capacity



WARNING:

Do not operate the pump below the minimum rated flows or with the suction or discharge valves closed. These conditions can create an explosive hazard due to vaporization of pumped fluid and can quickly lead to pump failure and physical injury.

 Driver may overload if the pumpage specific gravity (density) is greater than originally assumed, or the actual flow is much less than the rated flow.

The pump and system must be free of foreign objects. If pump becomes plugged, shut down and unplug prior to restarting pump.

Listed below are some causes for circulation loss. Keep in mind that operation at reduced capacities can cause damage to the pump.

1. Increase in TDH against which pump operates could be caused by:
 1. Heat exchanger tubes partially plugged.
 2. Too many heat exchanger tubes blanked off
 3. Improperly sized or partially plugged strainer.
2. Viscosity of slurry higher than it should be.
3. Pump speed low. V-belt drive may be slipping and operating pump below design speed.
4. Pump throttled on suction side. This could be caused by:
 1. rubber lining pulling away from the suction pipe and partially collapsing,
 2. large solids dropping into the suction, or
 3. by an improperly sized or-plugged strainer in the suction pipe.
5. Pump partially plugged by large solid jammed between two impeller blades. This will also cause rough operation with excessive vibration.
6. Incorrect pump rotation. When changing motors for any reason or after any electrical system changes or modifications, always check motors for correct direction of rotation.
7. Worn pump impeller and/or casing. On a new pump, clearance between tip of impeller blade and casing or elbow is carefully determined. As this clearance increases, pump performance decreases.

It is not practical to predict performance at any given clearance without running a test at this clearance. On small pumps, this effect is magnified as the percentage of impeller blade area lost from wear and corrosion is higher.

Other pump conditions and possible causes are:

High HP demand

1. Increased head or viscosity
2. Pump speed too high
3. Specific-gravity of slurry higher-than normal
4. Packing gland pulled up too tight
5. Impeller rubbing in casing

Noisy or rough operation

1. Throttled suction or plugging
2. Impeller rubbing in casing

Damage occurs from:

1. Increased vibration levels - Affects bearings, stuffing box seal chamber, and mechanical seals.
2. Heat build up - Vaporization causing rotating parts to score or seize.
3. Cavitation - Damage to internal surfaces of pump.
4. Loose impeller
5. Broken impeller blade
6. Bearings not properly lubricated
7. Bent shaft
8. Impeller out of balance.

Operating under freezing conditions

Exposure to freezing conditions, while pump is idle, could cause liquid to freeze and damage the pump. Liquid inside pump should be drained.

Shut down the pump

1. Turn off power to pump motor.
2. In case of necessary maintenance or pump inspection, lock driver to prevent accidental rotation.



WARNING:

When handling hazardous and/or toxic fluids, skin and eye protection are required. If pump is being drained, precautions must be taken to prevent physical injury. Pumpage must be handled and disposed of in conformance with applicable environmental regulation.

Final Alignment

1. Run the pump under actual conditions for a sufficient length of time to bring the pump and driver up to operating temperature.
2. Check alignment per alignment procedure outlined earlier.

Maintenance

Preventative Maintenance

A routine maintenance program can extend the life of your pump. Well maintained equipment will last longer and require fewer repairs. You should keep maintenance records, this will help pinpoint causes of problems.

Condition monitoring

 For additional safety precautions, and where noted in this manual, condition monitoring devices should be used.

- Pressure gauges
- Flow meters
- Level indicators
- Motor load readings
- Temperature detectors
- Bearing monitors
- Leak detectors
- PumpSmart control system

For assistance in selecting the proper instrumentation and its use, please contact your ITT/ Goulds representative.

Maintenance schedule

NOTICE:

 The preventive maintenance section must be adhered to in order to keep the applicable ATEX classification of the equipment. Failure to follow these procedures will void the ATEX classification for the equipment.

 Inspection intervals should be shortened appropriately if the pumpage is abrasive and/or corrosive, or if the environment is classified as potentially explosive.

NOTICE:

When handling hazardous and / or toxic fluids, proper personal protective equipment should be worn. If pump is being drained, precaution must be taken to prevent physical injury. Pumpage must be handled and dispersed of in conformance with applicable environment regulations.

Maintenance inspections

A maintenance schedule includes these types of inspections:

- Routine maintenance
- Routine inspections
- Three-month inspections
- Annual inspections

Shorten the inspection intervals appropriately if the pumped fluid is abrasive or corrosive or if the environment is classified as potentially explosive.

Routine inspections

Perform these tasks whenever you check the pump during routine inspections:

- Check the level and condition of the oil through the sight glass on the bearing frame.
- Check for unusual noise, vibration, and bearing temperatures.
- Check the pump and piping for leaks.

- Analyze the vibration.

Three-month inspections

Perform these tasks every three months:

- Check that the foundation and the hold-down bolts are tight.
- Check the packing if the pump has been left idle, and replace as required.
- Change the oil every three months (2000 operating hours) at minimum.
 - Change the oil more often if there are adverse atmospheric or other conditions that might contaminate or break down the oil.
- If any rubbing noise has been noticed, re-align the impeller.

Annual inspections

Perform these inspections one time each year:

- Check the pump capacity.
- Check the pump pressure.
- Check the pump power.

If the pump performance does not satisfy your process requirements, and the process requirements have not changed, then perform these steps:

1. Disassemble the pump.
2. Inspect it.
3. Replace worn parts.

Bearing Maintenance

 Operation of the unit without proper lubrication will cause bearing failure, and pump seizure.

 Throughout this section on bearing lubrication, different pumpage temperatures are listed. If the equipment is ATEX certified and the listed temperature exceeds the applicable value shown in the table under ATEX identification, then that temperature is not valid. Should this situation occur, please consult with your ITT/Goulds representative.

Oil Lubricated Bearings

1. Remove the bearing housing breather (113A) and add oil until oil level is at the center of the sight glass.
2. If the unit has an external oil lube system, fill the bearing housing and the reservoir to satisfy the system requirements.
3. Replace the breather.
Refer to Oil Volume table for required oil volume.

Table 7: Axial flow pump oil volume

Pump Size	Quarts	Litres
6"	0.5	0.5
8"	0.6	0.5
10"	0.9	0.9
12"	5.3	5.0
14"	5.9	5.6
16"	8.4	8.0
18"	9.6	9.1
20"	20.7	19.6
24"	22.5	21.3
700mm	32.3	30.5
30"	50.1	47.4
36"	52.6	49.8

Approximate values only. Always fill using sight glass to verify level. Oil level should be at the center of the sight glass. See comments in this section.

⚠ Bearings must be lubricated properly in order to prevent excess heat generation, sparks and premature failure.

4. Run the pump for 1 minute to fill the oil galleys and in and around each bearing. Check the sight glass and add oil accordingly. Monitor the oil level indicator for the first 24 hours of operation and maintain fill level.

Grease lubricated bearings (6-18 inch sizes only)

The bearings are pre-lubricated at the factory. Re-grease bearings every 500 operating hours or after every 3 weeks of continuous operation.

Regrease procedure

NOTICE:

When re-greasing there is danger of impurities entering the bearing housing. The grease container, the grease device, and fittings, must be clean.

1. Wipe dirt from the grease fittings.
2. Fill both grease cavities through the grease fittings (193A and 193B) found on the bearing housing (134C). Use recommended grease and fill until slight resistance is felt in the grease gun.
3. Wipe excess grease from fittings.
4. Ensure the bearing housing labyrinth seals are still seated in place and have not been pushed from their seats by grease pressure.

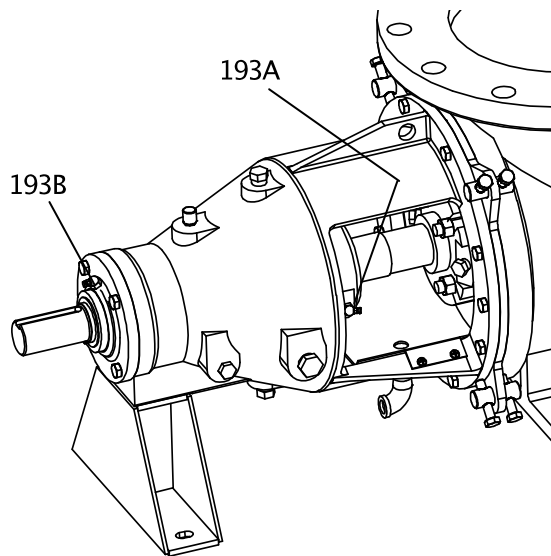

Figure 25: Fill bearing grease cavities

NOTICE:

The bearing temperature usually rises after re-greasing due to an excess supply of grease. Temperature will return to normal after pump has run and purged excess from the bearings, usually two to four hours.

For most operating conditions a lithium complex soap based grease of NLGI consistency No. 2 is recommended. This grease is acceptable for bearing temperatures of -26°C to 177°C | -15°F to 350°F . If another brand is desired, it should be checked with the supplier for being equivalent to the above.

Table 8: Lubricating grease requirements

Lubricant brand	Pumpage temp. below 177°C 350°F	Pumpage temp. above 177°C 350°F
NLGI Grade	2	3
Mobil	Mobilux #2	----
Mobil	Mobilith AW2	Mobilith AW3
Humble	Lidok #2	----
Exxon	Unirex N2	Unirex N3
Shell	Alvania #2	----
Sunoco	Multipurpose EP	----
SKF	LGMT 2	LGMT 3
Texaco Regal	Starfak #2	----

Bearing temperatures are generally about 18°C | 20°F higher than bearing housing outer surface temperature.

**CAUTION:**

Never mix greases of different consistencies (NLGI 1 or 3 with NLGI 2) or with different thickeners. For example, never mix a lithium-based grease with a polyurea-based grease. Doing so may result in decreased performance.

Pumpage temperatures above 177°C | 350°F should be lubricated by a high temperature. Mineral oil grease. Mineral oil greases should have oxidation stabilizers and a consistency of NLGI 3.

Shaft-seal maintenance

Mechanical-seal maintenance

**WARNING:**

 The mechanical seal used in an Ex-classified environment must be properly certified. Prior to startup, make sure that all areas that could leak pumped fluid to the work environment are closed.

**CAUTION:**

Never operate the pump without liquid supplied to mechanical seal. If you run a mechanical seal dry, even for a few seconds, this can cause seal damage. Physical injury can occur if a mechanical seal fails.

Cartridge-type mechanical seals

Cartridge-type mechanical seals are commonly used. Cartridge seals are preset by the seal manufacturer and require no field settings. Cartridge seals installed by the user require disengagement of the holding clips prior to operation, allowing the seal to slide into place. If the seal has been installed in the pump by ITT, these clips have already been disengaged.

Other mechanical seal types

For other types of mechanical seals, refer to the instructions provided by the seal manufacturer for installation and setting.

Before you start the pump

Check the seal and all flush piping.

Packed stuffing-box maintenance



WARNING:

- Never attempt to replace the packing until the driver is properly locked out and the coupling spacer is removed.

Adjustment of gland

Adjust the gland if the leakage rate is greater than or less than the specified rate. Evenly adjust each of the two gland bolts with a one-quarter (1/4) turn until the desired leakage rate is obtained. Tighten the bolts to decrease the rate. Loosen the bolts to increase the rate.

Tightening of packing

NOTICE: Never over-tighten packing to the point where less than one drop per second is observed. Over-tightening can cause excessive wear and power consumption during operation.

If you cannot tighten the packing to obtain less than the specified leakage rate, then replace the packing.

Packed Stuffing Box

If the axial flow pump has a standard stuffing box to seal the rotating shaft the packing rings were installed at the factory, but at some point during the life of the pump they must be replaced. The following steps are used to replace the standard packing:

1. Drain the system or isolate the pumpage from the pump before replacing the packing.
2. Remove the nuts from the gland studs that hold the gland in place.
3. Use a packing puller remove the first (2) rows of packing from the box.
4. Use threaded rods or a packing puller to remove the lantern ring from the box.
5. Use a packing puller remove the second (2) rings of packing from the box.
6. Use threaded rods or a packing puller to remove the second lantern ring from the box.
7. Use a packing puller remove the final ring of packing from the bottom of the box.
8. Clean the stuffing box of any grit or build-up. Clean the shaft sleeve prior to replacing the packing. If the sleeve is damaged now is the time to replace it.
9. Install the packing and lantern ring in the reverse order of removal, 1 rings of packing, lantern ring, 2 rings of packing, lantern ring, 2 rings of packing, and the gland. Firmly seat each ring. Stagger joints in each ring 90°. Make sure middle of lantern ring lines up with flush tap in the stuffing box.
10. Die formed packing rings are used when re-packing a box. Care must be used during their installation. To install packing, twist the ring sideways just enough to get it around the shaft. Do not attempt to pull rings straight out, see Figure: *Packing rings*.

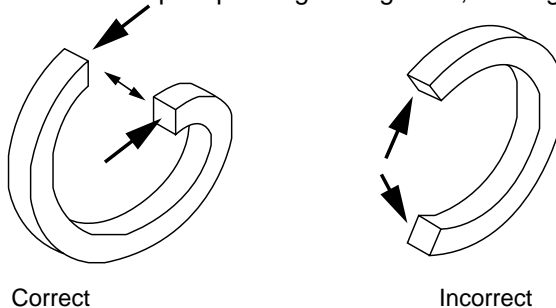

Figure 26: Packing rings

11. Insert the lantern ring with tapped extractor holes facing outward from the box, be sure it is aligned with the flush ports in the stuffing box.

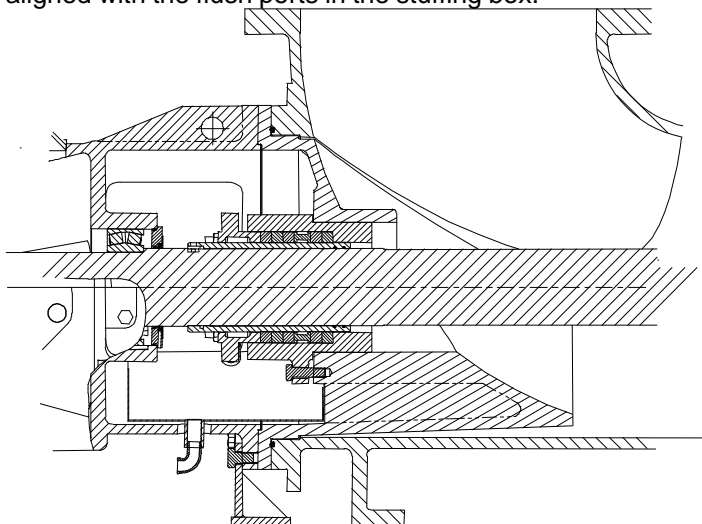

Figure 27: Insert lantern ring

12. Install the gland nuts finger tight. Then with the lubricating supply on and the pump running, gradually tighten the gland nuts one flat at a time, while observing the leakage and stuffing box temperature. Packing requires time to run-in.
13. Allow a minimum of ½ hour between adjustments. If the leakage is reduced quickly, the packing will overheat and may be destroyed. The shaft sleeve may also become damaged. The normal leakage for a properly adjusted stuffing box, depending on the shaft size and speed, varies from a few drops per second to a small trickle out of the gland.

Connection of Sealing Liquid

If stuffing box pressure is above atmospheric pressure and the pumpage is clean, normal gland leakage of 40-60 drops per minute is usually sufficient to lubricate and cool packing and sealing liquid is not required.

NOTICE: If stuffing box is below atmospheric pressure or pumpage is not clean, an external flush should be used to lubricate and cool packing.

An external sealing liquid is required when:

1. Abrasive particles in the pumpage could score the shaft sleeve.
2. Stuffing box pressure is below atmospheric pressure due to pump running when suction source is under vacuum. Under these conditions, packing will not be cooled and lubricated and air will be drawn into the pump. If an outside source of clean compatible liquid is required, The piping should be connected to the stuffing box flush port inlet.
3. If an outside source of clean liquid is required:
 1. The pressure should be 1.1-1.4 kg/cm² | 15-20 psi above suction pressure.
 2. Under extreme temperature and pressure a pipe should also be connected to the flush port outlet.

NOTICE: Most packing requires lubrication. Failure to lubricate packing may shorten the life of the packing and pump.

4. An external drip pan (799G) drain is provided to carry away normal gland leakage.

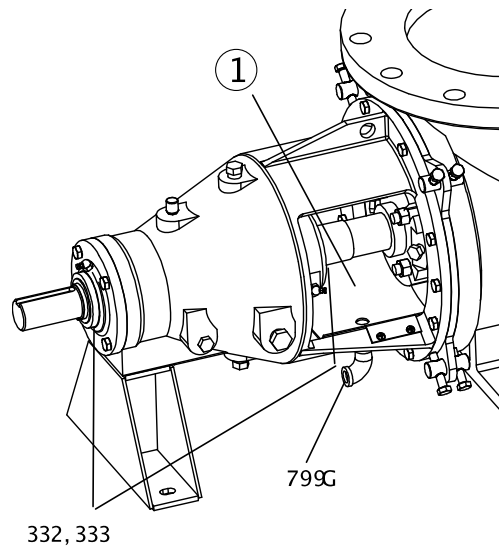

1. Drip pan (supplied with packing only)

Figure 28: External drip pan drain

Labyrinth Seals

Labyrinth seals are found on the inboard and outboard end caps of the bearing housing to prevent contaminants from entering the bearing housing.

On some older models lip seals were used. These were assisted by cast slingers that fling contaminant fluids away prior to reaching the lip seals. Lip seals do not require any preventative maintenance but should be replaced during any rebuild operations. They can be cleaned occasionally from the outside by removing the slingers.

Disassembly

Pump Disassembly Precautions

NOTICE:

Make sure that all replacement parts are available before you disassemble the pump for overhaul.

**WARNING:**

Lock out power to prevent accidental start-up and physical injury.

1. Shut all valves controlling flow "to and from" the pump.
2. Drain liquid from piping, flush the pump if necessary.
3. Disconnect all auxiliary piping and tubing.
4. If the pump is oil lubricated drain all oil from the bearing housing before attempting to move the pump.
5. Depending on the drive arrangement, either direct connect or V-belt, follow steps as applicable.

Disassembly precautions

**WARNING:**

- Chemical hazard. You must individually decontaminate each component according to all federal, state, local, and company environmental regulations.
 - A build up of gases within the pump, sealing system, or process-piping system can result in an explosive environment within the pump. Make sure that the process piping system, pump, and sealing system are properly vented prior to operation.
 - Burn Hazard. Coupling may be hot. Use proper protection when handling.
 - Burn Hazard. use proper protection when handling bearings.
 - Worn parts may have sharp edges. Wear heavy work gloves while handling.
 - Chemical Hazard. A small amount of liquid may be left in the pump.
 - Process fluid leaks can result in an explosive atmosphere. Follow all pump and seal assembly procedures.
 - Make sure that the pump is isolated from the system and that pressure is relieved before you disassemble the pump, remove plugs, open vent or drain valves, or disconnect the piping.
 - Crush hazard. The unit and the components can be heavy. Use proper lifting methods and wear steel-toed shoes at all times.
 - The pump can handle hazardous and toxic fluids. Identify the contents of the pump and observe proper decontamination procedures in order to eliminate the possible exposure to any hazardous or toxic fluids. Wear the proper personal protective equipment. Potential hazards include, but are not limited to, high temperature, flammable, acidic, caustic, explosive, and other risks. You must handle and dispose of pumped fluid in compliance with the applicable environmental regulations.
-



CAUTION:

- You must keep the shop area clean and free of any substances that can contaminate the magnets, such as ferrous metals.
 - The magnets in this unit are extremely powerful. Beware of serious injury to fingers and hands. Keep magnetic drive components and magnetic tools apart by a minimum of 3 ft (1 m).
-

NOTICE:

Use a bench with a non-magnetic work surface such as wood or brass when you work on the pump.

Remove the coupling guard

1. Remove the nut, bolt, and washers from the slotted hole in the center of the coupling guard.
2. Slide the driver half of the coupling guard toward the pump.

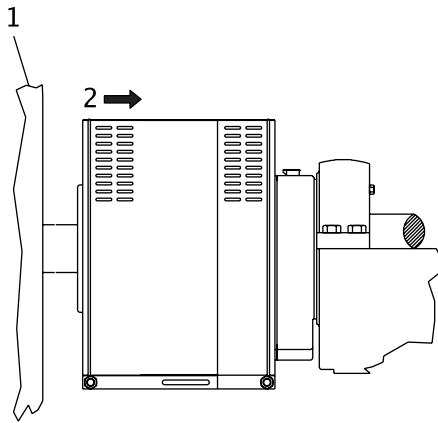

1. Driver
 2. Slide to remove
3. Remove the nut, bolt, and washers from the driver half of the coupling guard.

4. Remove the driver-side end plate.

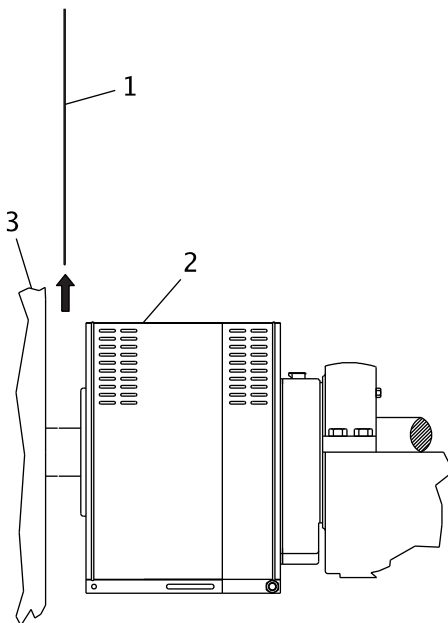

1. End plate
2. Coupling guard half
3. Driver

5. Remove the driver half of the coupling guard:
 - a) Slightly spread the bottom apart.
 - b) Lift upwards.
6. Remove the remaining nut, bolt, and washers from the pump half of the coupling guard. It is not necessary to remove the end plate from the pump side of the bearing housing. You can access the bearing-housing tap bolts without removing this end plate if maintenance of internal pump parts is necessary.
7. Remove the pump half of the coupling guard:
 - a) Slightly spread the bottom apart.
 - b) Lift upwards.

Tools required

In order to disassemble the pump, you need these tools:

- Allen wrenches
- Bearing puller
- Brass drift punch
- Cleaning agents and solvents
- Feeler gauges
- Induction heater
- Lifting sling
- Micrometer
- Torque wrench with sockets
- Wrenches
- Safety glasses, leather gloves
- Spanner wrench
- Crane or hoist
- Lifting eyebolt (dependent on pump size)

Disassemble the guard / drive (v-belt configuration)

Direct drive configuration

1. Remove the pump coupling guard screws and guard (501).

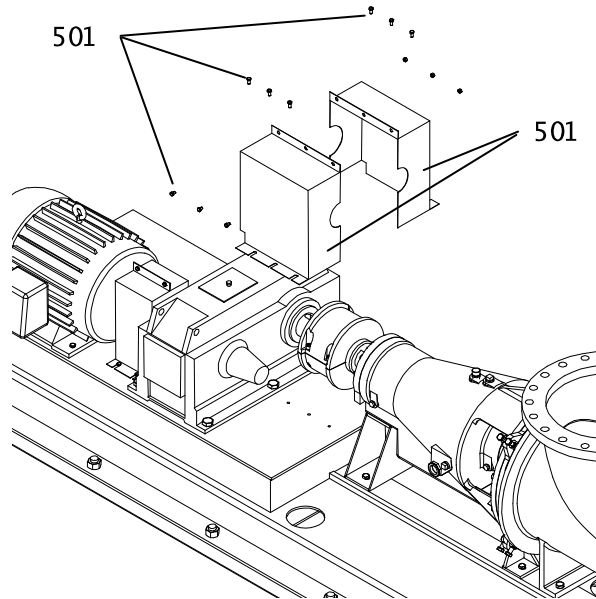
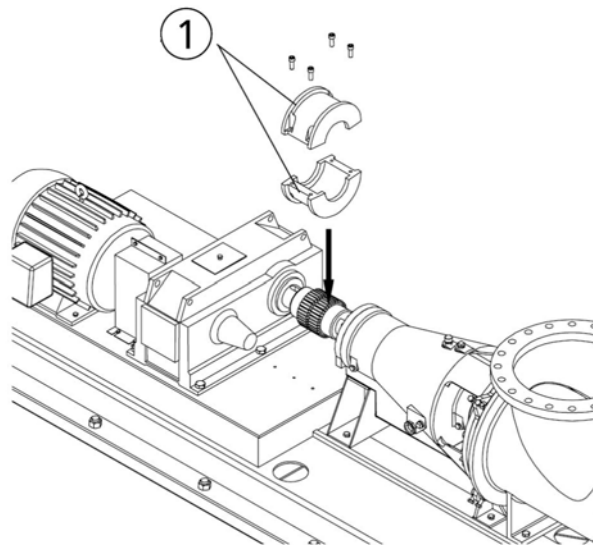

Figure 29: Pump guard removal

2. Remove the fasteners that hold the coupling cover halves together, remove each half and set it aside for re-assembly. Do not remove the hubs from the gear drive and pump shafts.



1. Coupling covers

Figure 30: Coupling cover removal

3. Remove the pump to sub-base bolts (372V) and wrap lifting straps or chains around the bearing housing (134C) and elbow (315A).

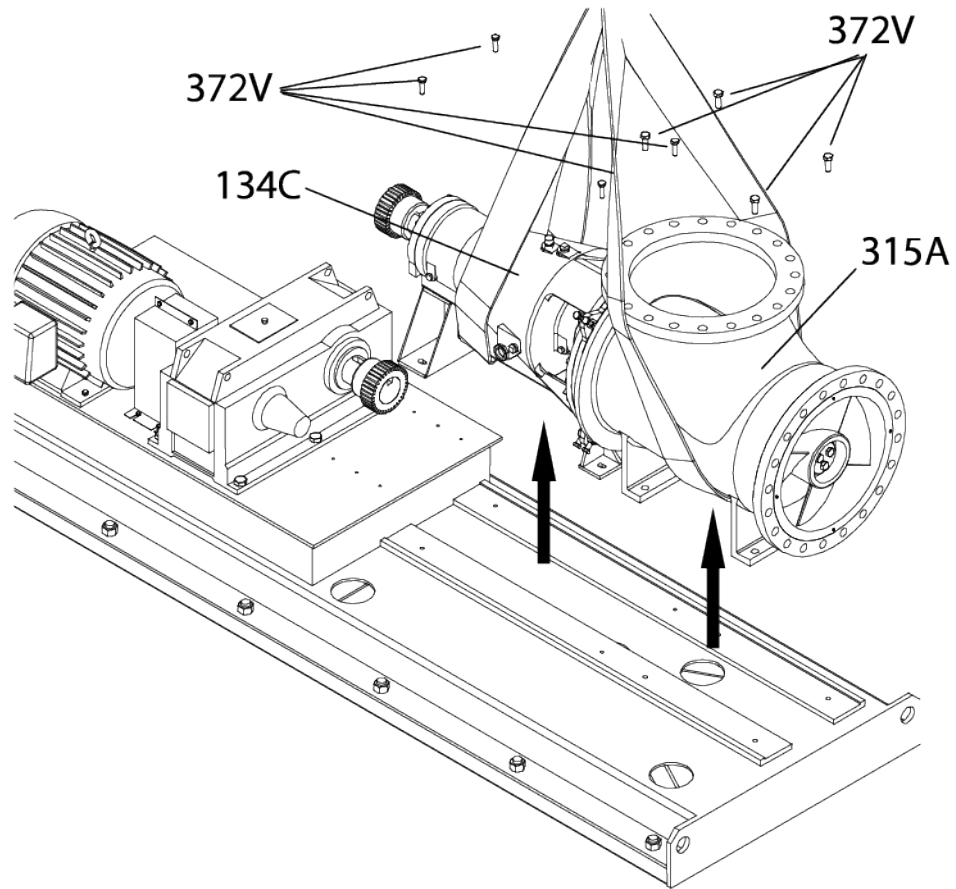

Figure 31: Removal of pump from sub-base

Use care when lifting the pump from the sub-base. Be sure all lifting devices are rated for the pump weight. If any shims are found under the bearing housing feet match mark and retain them for re-assembly.

V-belt configuration

4. Remove the V-belt guard screws and the guard cover (500) from guard base.

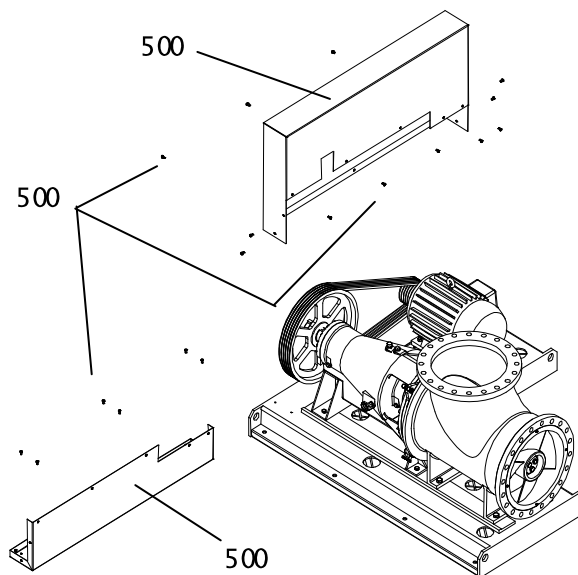
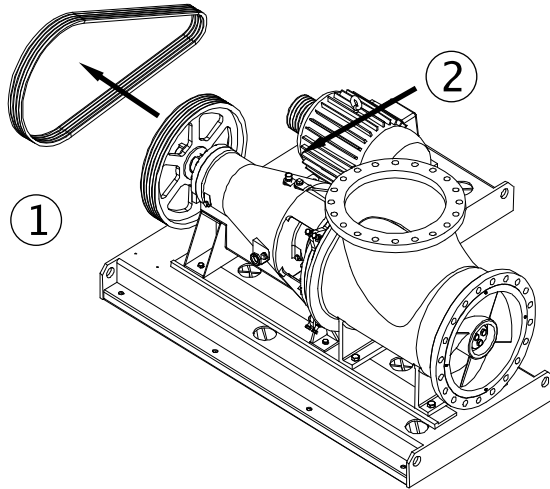

Figure 32: Guard cover removal

5. Relieve the belt tension by adjusting the slide base toward the pump then remove the belts.



1. Remove belts
2. Shift slide base

Figure 33: Belt removal

6. Remove the pump to sub-base bolts (372V) and wrap lifting straps or chains around the bearing housing (134C) and elbow (315A).

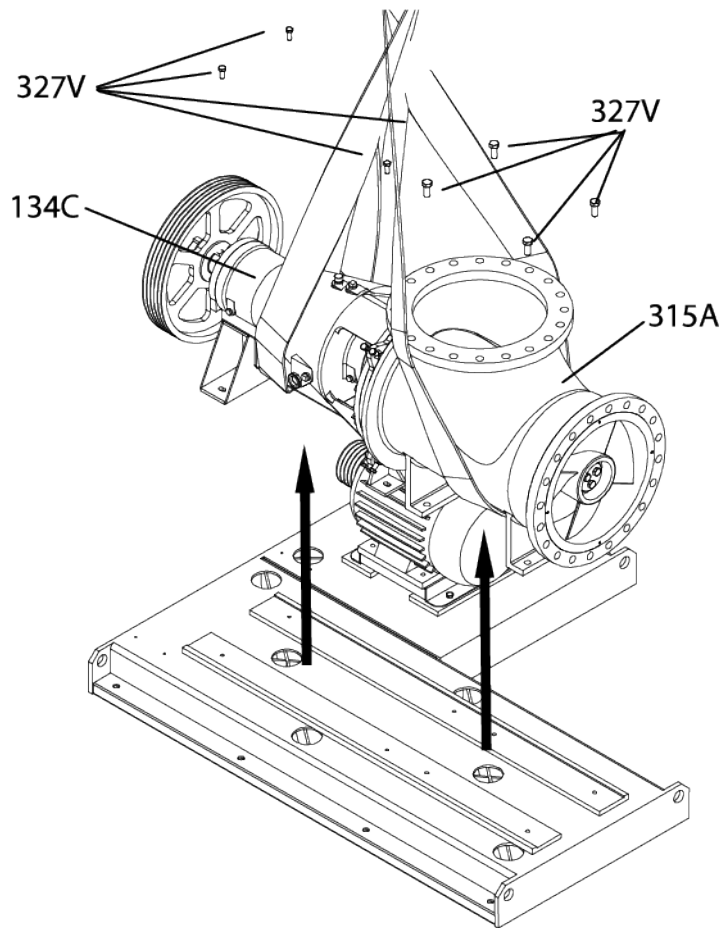

Figure 34: Pump lifting

- 7.
8. Using a crane, lift the pump vertically from the sub-base.

Be careful not to damage the pump by striking any beams or walls that may be near the pump.

9. If any shims are found under the bearing housing feet retain them for re-assembly later.
10. Depending on the drive type, remove the hub fasteners that hold the coupling or pump sheave to the shaft (122).
11. Remove either a coupling half or pump sheave and key (400).
If the coupling half is interference fit, heat may be necessary to remove it from the shaft. Drive instructions are included with the data package. Follow the manufacturer's instructions for coupling or sheave removal.

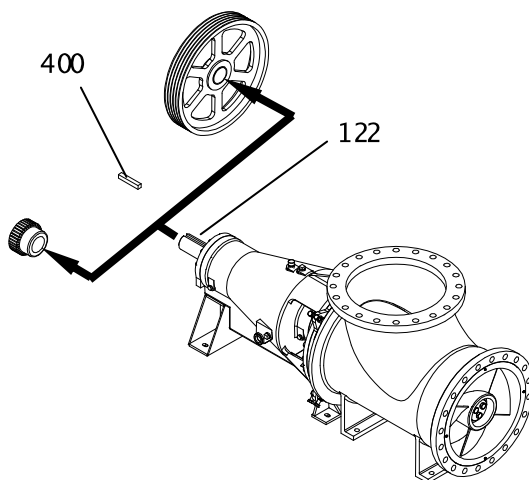
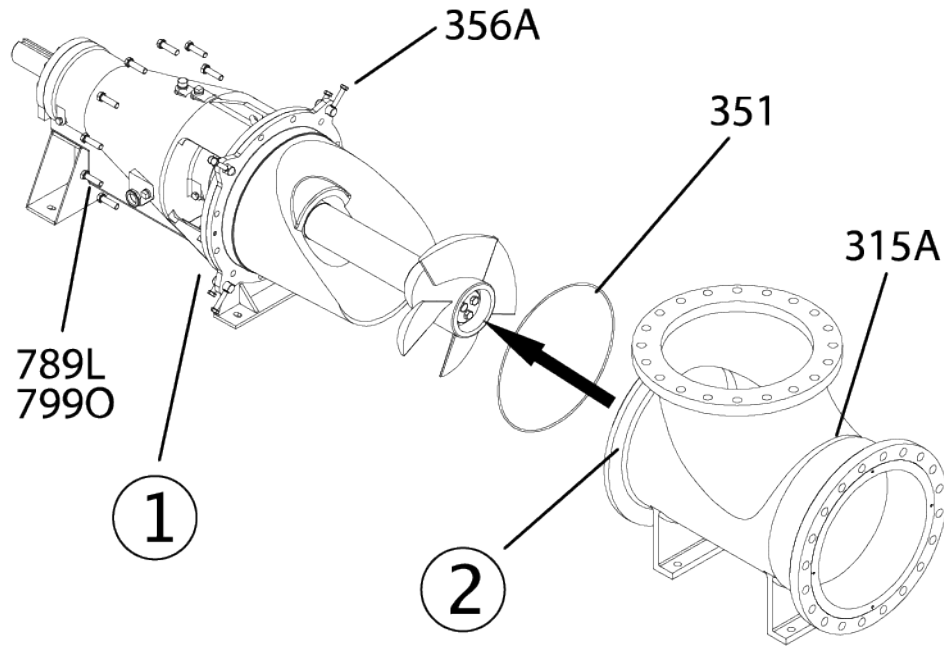

Figure 35: Coupling half or pump sheave removal

Disassemble the back-pullout / elbow (cast back-pullout design only)

1. Set the pump down on a smooth flat surface to stabilize it for disassembly.
2. Loosen the impeller adjusting bolts (356A) so that they are clear of the rear elbow flange.
3. Text of third step.
4. Remove the bolts (789L, 799O) that attach the back-pullout (903A) to the elbow (315A).
5. With the elbow held in place, slide the back-pullout from the elbow.
6. Remove the face o-ring (351) between the elbow and the back-pullout, discard and order a replacement.
Be sure to order the correct o-ring material.



1. Back-pullout 903A
2. Rear elbow flange

Figure 36: Back-pullout / elbow disassembly

Disassemble the back-pullout elbow with casing (cast back-pullout design only)

The 700mm and 36" sizes come with a separate casing.

1. Remove the bolts (799C) and nuts (799D) that secure the casing (100) to the elbow (315A).
2. Remove the casing and discard the mating o-ring or gasket (351A).
3. Loosen the four screws (356A).
4. Remove the bolts (789I & 799O) that secure the back-pullout (903A) to the elbow and discard the o-ring (351).

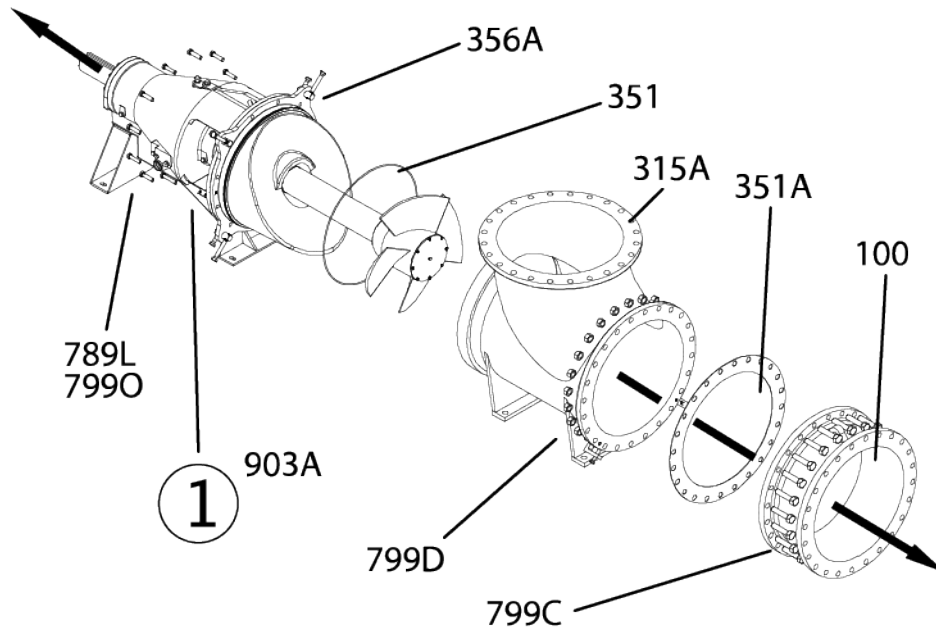

1. Back-pullout
Figure 37: Elbow with casing

Disassemble the power frame from elbow (fabricated elbow design only)

Remove the standard impeller

1. Remove the bolts (198) that hold the shaft washer (199) in place.
2. Remove the shaft washer.
3. To remove the impeller (101), use a wooden mallet and gently tap it to break it loose from the shaft (122).
4. Pull the impeller from the shaft using the Goulds impeller assembly tool or some other device. Refer to instructions on use of the Goulds impeller assembly tool [Installation and Removal of the 30 inch and 36 inch Impeller Using the Goulds Impeller Assembly Tool](#) (page 123) in Appendix II. Retain the impeller key (178).

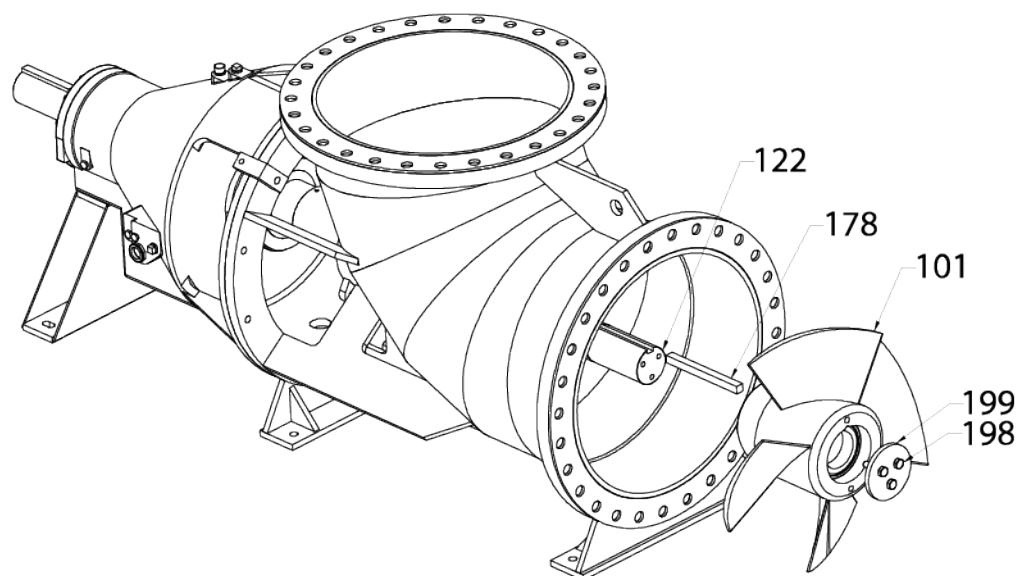

Figure 38: Removal of the standard impeller from the fabricated elbow

Remove the sealed impeller

700mm and 36" sizes use an impeller cover (998E) and O-ring (412T) to keep pumpage out of the impeller cavity. The impeller cover must be removed first to get to the shaft washer (199).

1. Remove the bolts (799B) and cover (998E) from the impeller (101).
2. Remove the cover O-ring (412T).
3. Remove the bolts (198) and shaft washer (199).
4. To remove the impeller (101), use a wooden mallet and gently tap it to break it loose from the shaft (122).
5. Pull the impeller off the shaft using the Goulds impeller assembly tool or some other device. Refer to instructions on use of the Goulds impeller assembly tool in Appendix II. Retain the impeller key (178), and discard the impeller O-ring (412A).

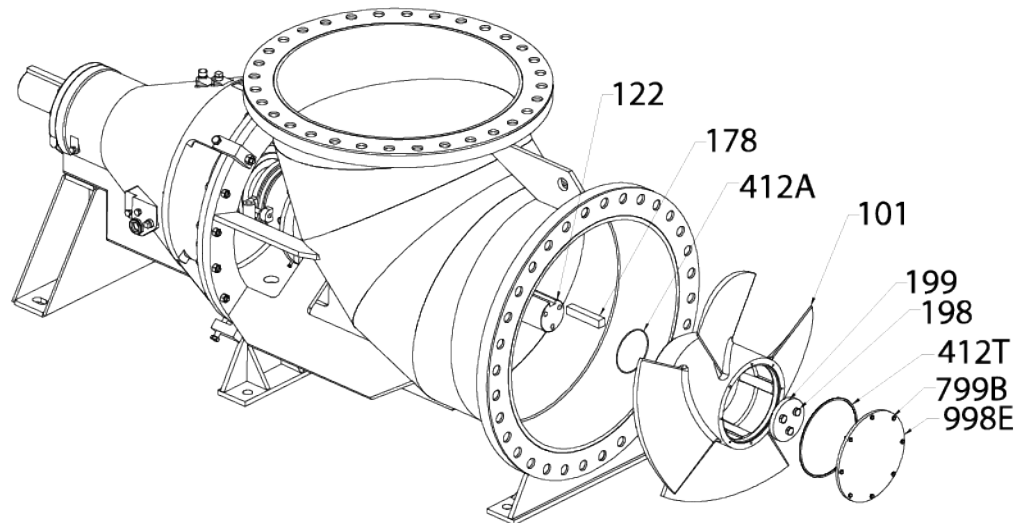

Figure 39: Removal of sealed impeller from fabricated elbow

If pump was supplied with packing, disassemble the Packing Chamber and Packing

1. Remove the gland nuts (355) from the gland studs (353).
2. Remove the packing gland (107) from the packing chamber (220).
3. Remove the packing chamber nuts (425) from the packing chamber studs (799E).
4. Slide the packing chamber away from the elbow – the packing (105) and lantern ring (106) will move with it.

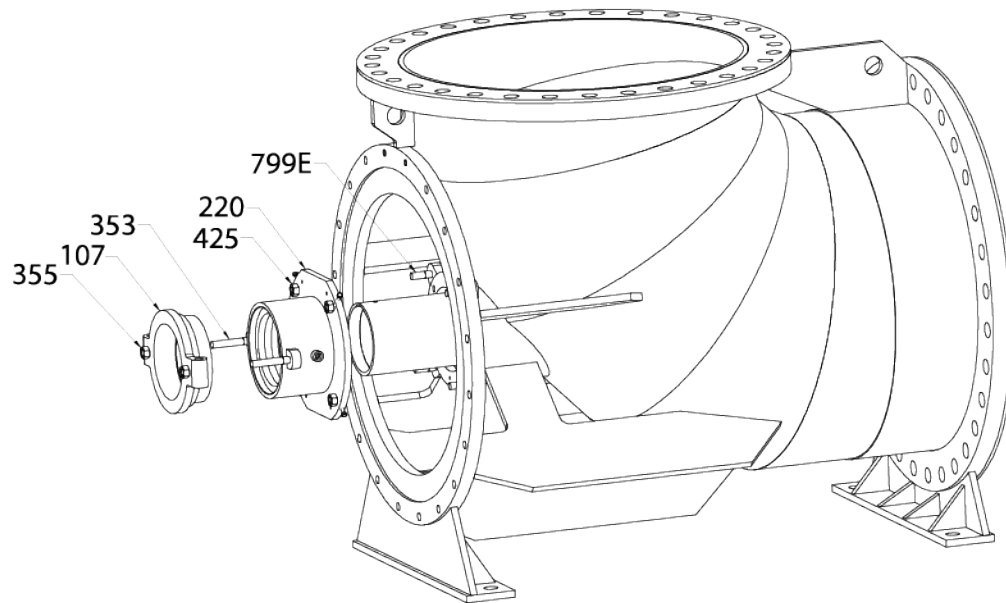

Figure 40: Removal of the packing chamber and gland from the elbow

If the pump was supplied with a mechanical seal, disassemble the mechanical seal

1. Reinstall the clips on the mechanical seal (if applicable)
2. Remove the gland nuts (355) from the gland studs (353).
3. Slide the mechanical seal (383) on the shaft (122) away from the mechanical seal adapter (108D).

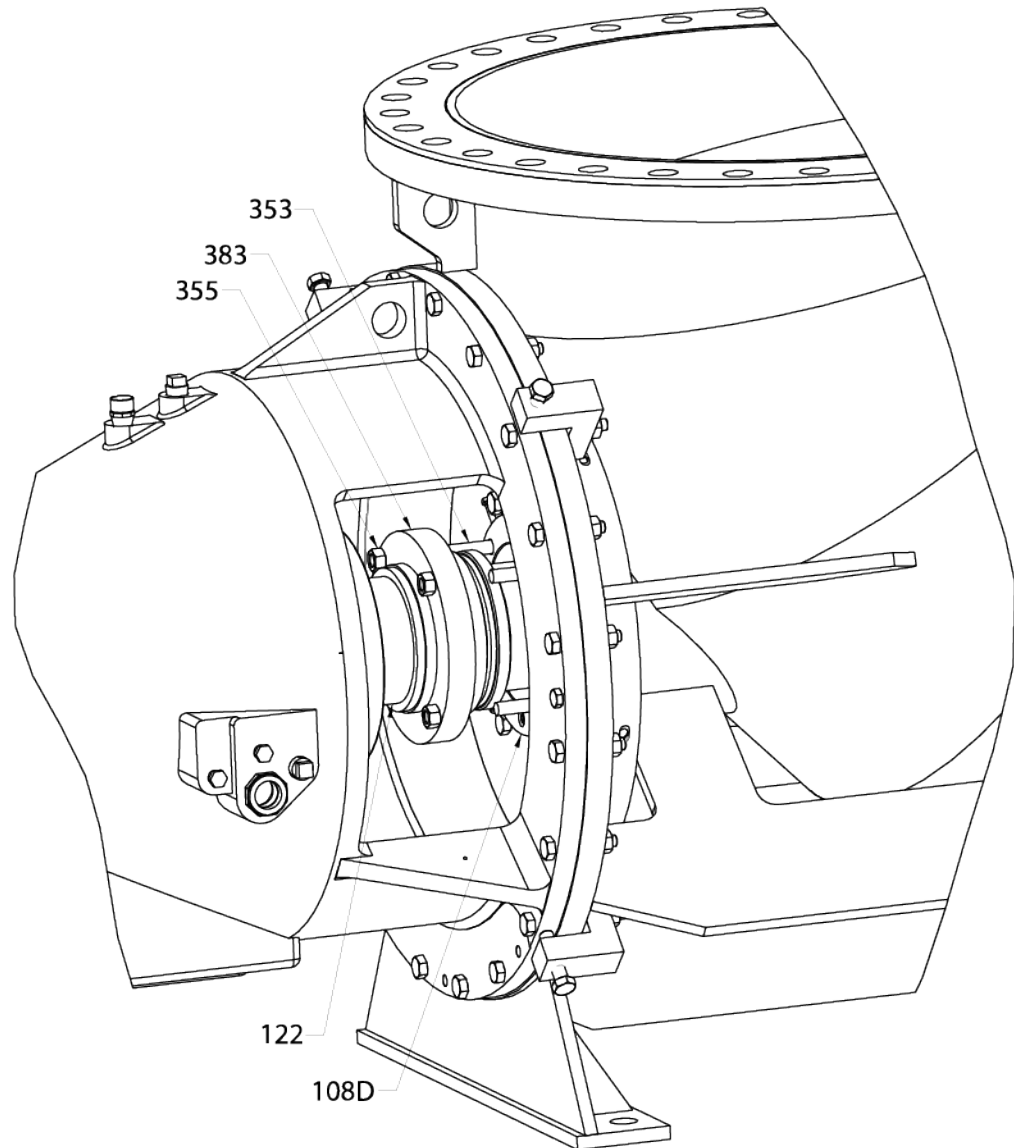

Figure 41: Removal of the mechanical seal from the mechanical seal adapter

Disassemble the Power Frame from the Elbow (Fabricated Elbow Design only)

1. Loosen the power end adjusting bolts (356A).
2. Remove the bolts (356E & 799O) and nuts (357A) that attach the power end to the elbow (315A).
3. With the elbow tied in place, slide the power frame from the elbow.

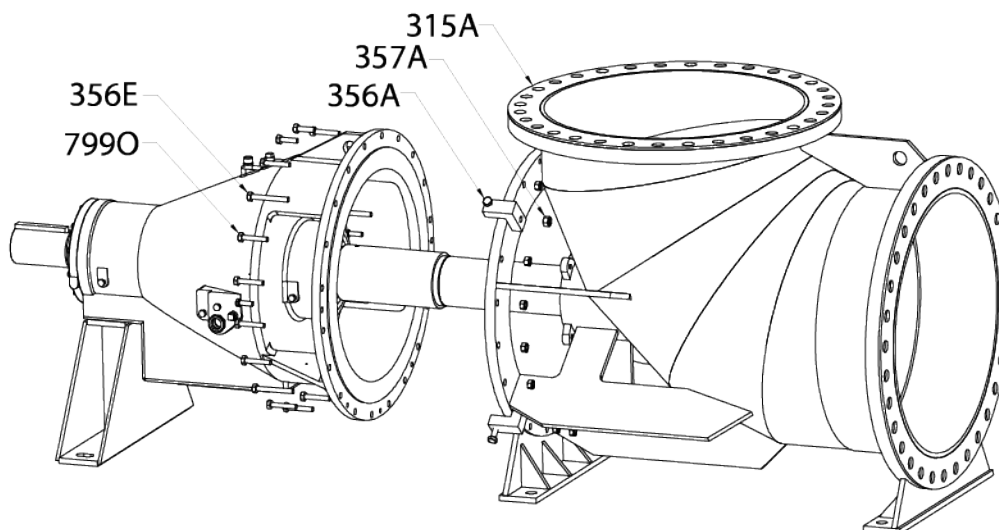
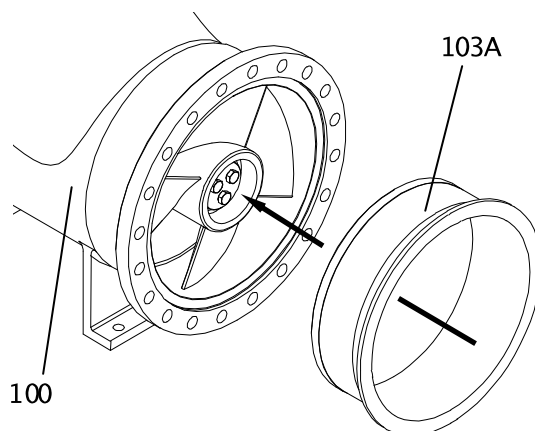

Figure 42: Removal of the power frame from the elbow (exclude the packing and mechanical seal)

Remove the liner (option)

If the elbow (315A) or casing (100) has an optional liner (103A) now is the time to remove it.

1. Jack the liner from its seat using the four tapped holes with screws, in the liner flange. If the liner has been in service this may require considerable effort due to corrosion. If the liner is worn or deeply eroded, order a replacement for re-assembly.



1. Jacking screws

Figure 43: Remove the liner (option)

Remove the standard impeller

1. Remove the bolts (198) that hold the shaft washer (199) in place.
2. Remove the shaft washer.
3. To remove the impeller (101), use a wooden mallet and gently tap it to break it loose from the shaft (122).
4. Pull the impeller from the shaft, retain the shaft key (178).

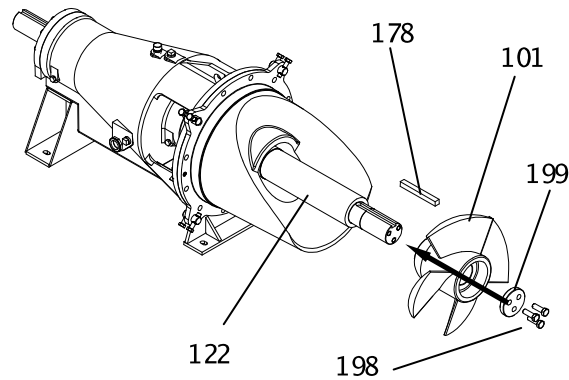

Figure 44: Standard impeller removal

Remove the sealed impeller

700mm and 36" sizes use an impeller cover (998E) and O-rings to keep pumpage out of the impeller cavity. The impeller cover must be removed first to get to the shaft washer (199).

1. Remove the bolts (799B) and cover (998E) from the impeller (101).
2. Remove the cover o-ring (412T).
3. Remove the bolts (198) and shaft washer (199).
4. To remove the impeller (101), use a wooden mallet and gently tap it to break it loose from the shaft (122).
5. Pull the impeller off the shaft, retain the shaft key (178), and discard the impeller o-ring (412A).
6. A pipe plug (358I) located in the center of the cover is used to test the impeller seal after re-assembly, do not remove this plug.

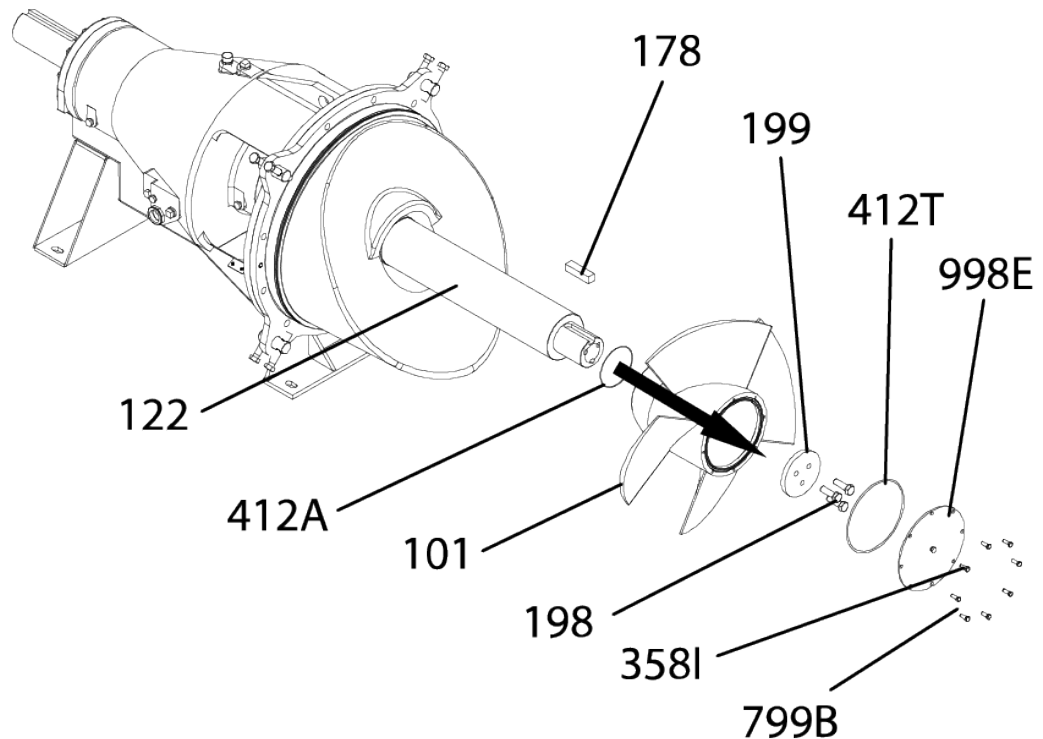

Figure 45: Sealed impeller removal

Remove mechanical seal with optional adapter (cast back-pullout design only)

Be sure all gland flush tubing is disconnected.

1. Remove the seal nuts (353) and pull the seal away from the stuffing box cover (184). It is unnecessary to remove the gland studs (355) unless they are damaged.
2. If the seal includes a restrictor bushing (496B) and optional adapter (108B) remove these now.
3. Remove and discard the adapter gasket (211).
4. Remove the stuffing box cover (184) by removing (2) screws (370C) that secure the stuffing box cover (184) to the bearing housing (134C).
5. Remove the stuffing box cover from the bearing housing.
On larger pumps use a sling or hook and chain to securely support the weight of the stuffing box cover during removal.
6. Remove the adjusting bolts (356A) and all four adjusting lugs (415).
Be careful not to scuff or scar the pump shaft (122) during removal.

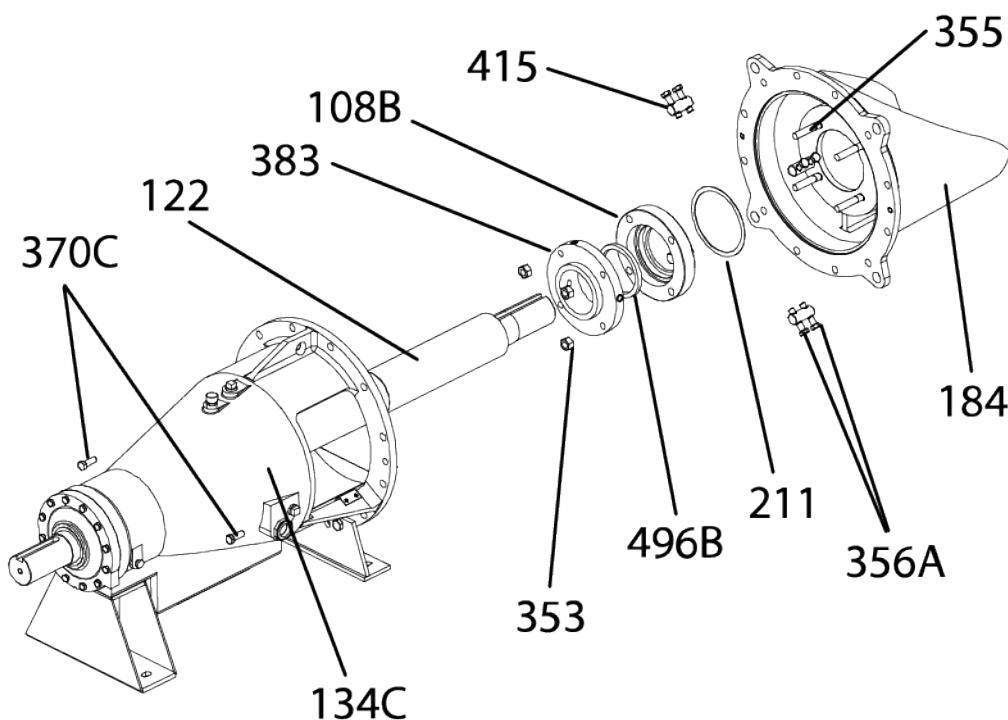

Figure 46: Mechanical seal with optional adapter

Remove the Mechanical Seal (Fabricated Elbow Design only)

If pump was supplied with mechanical seal, disassemble the mechanical seal

1. Remove mechanical seal (383) from the shaft (122).

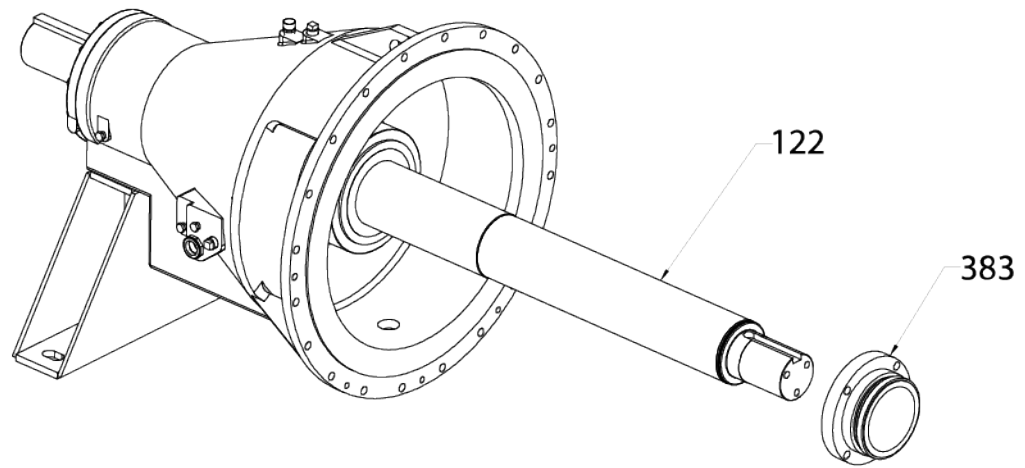

Figure 47: Removal of mechanical seal from shaft

Disassemble the packed box (cast back-pullout design only)

With a packed box, the gland nuts (353), gland (107), packing (106) and lantern ring (105) must be removed before the stuffing box cover (184).

1. Remove all flush tubing..
2. Remove the impeller adjusting bolts (365A) and all (4) adjusting lugs (415).
3. Remove the two bolts (370C) that secure the stuffing box cover (184) to the bearing housing (134C) then remove the stuffing box cover.

On larger pumps use a sling or hook and chain to support the weight of the stuffing box cover during removal. Be careful not to scuff or scar the pump shaft (122) or sleeve (126) during removal.

4. Remove the stuffing box (220), bolts (799E) and gasket (351W).
5. Remove the set screw (469D) and key (178D) that secure the shaft sleeve (126) to the shaft (122).

If the sleeve is immovable use a brass drift to knock it from its seat. Be careful not to mar or scratch the shaft during the process.

6. Remove and discard the o-rings (412D).

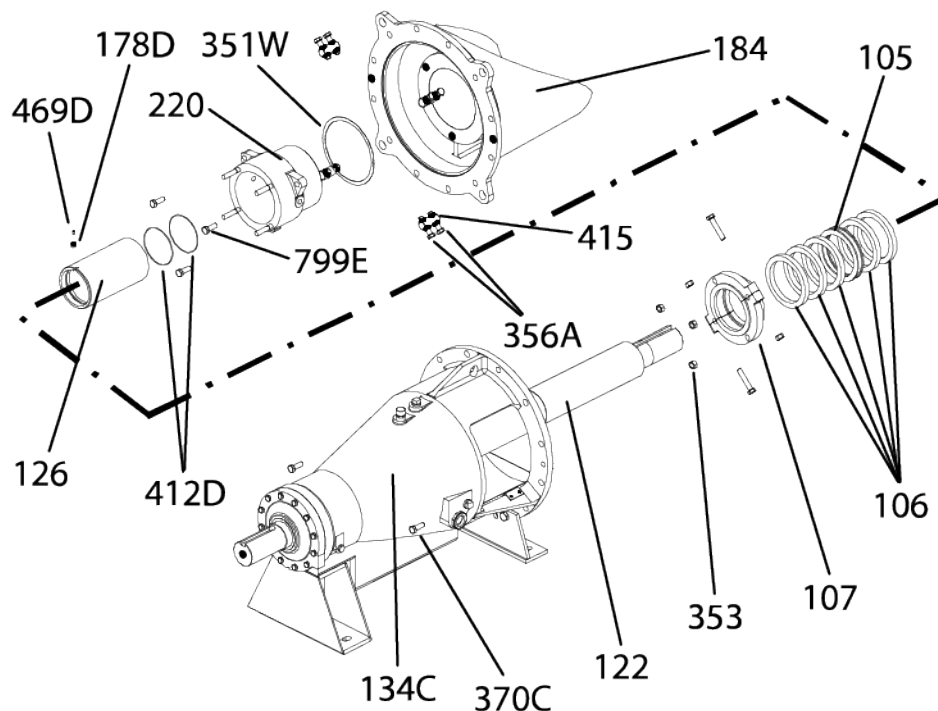

Figure 48: Packed box disassembly

Remove the Packing Chamber(Fabricated Elbow Design Only)

If pump was supplied with packing, disassemble the Packing Chamber and Packing

1. Disassemble the packing chamber O-ring (351W) from the packing chamber (220).
2. Remove packing chamber (220) from the shaft sleeve (126).
3. Remove the lantern ring (105) and packing (106) from the packing chamber or shaft sleeve, depending on where they have stayed.
4. Remove the packing gland (107).

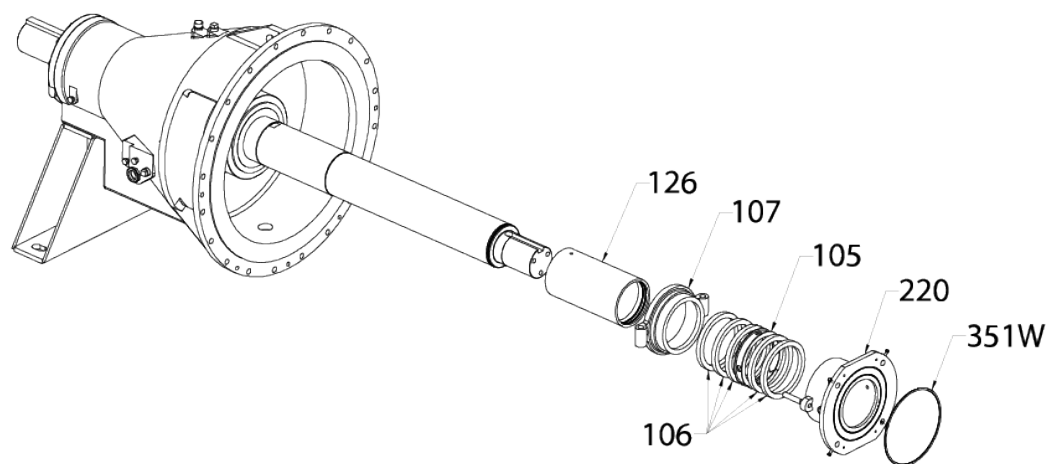

Figure 49: Packing chamber, packing, and lantern ring removal

Remove the drip pan

1. Remove the street elbow (799G) from the drip pan nipple.

2. Remove the screws (799H) and washers (799I) that secure the drip pan (179) to the bearing housing (134C).
3. Pull the drip pan from the bearing housing.

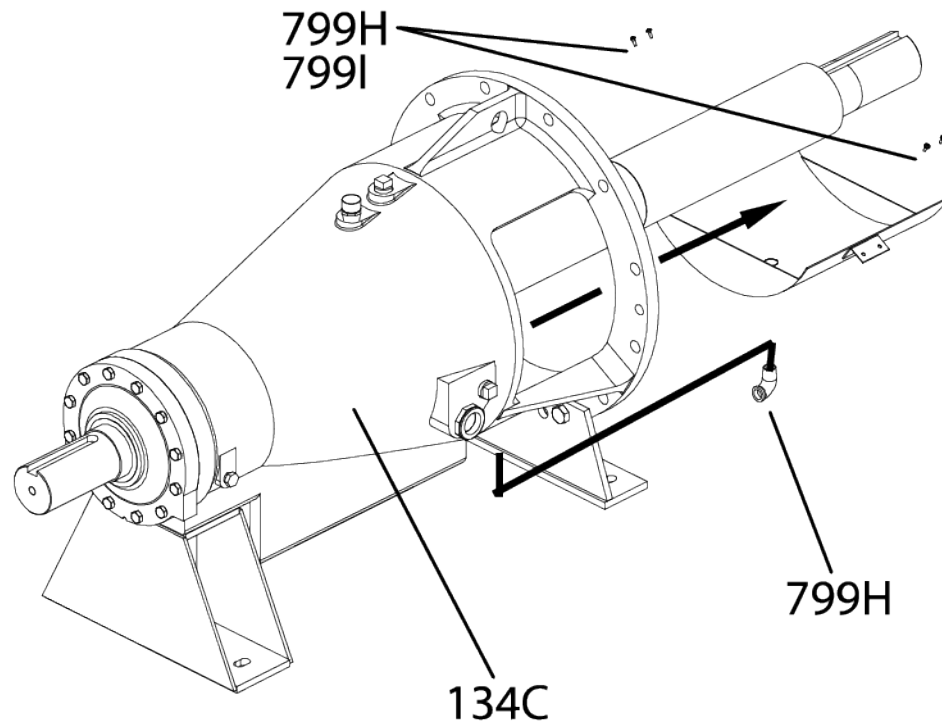

Figure 50: Drip pan removal

Disassemble the bearing housing

1. Before removing the bearings carefully remove the labyrinth seals from the outboard and inboard positions (332, 333).
2. Use a sharp edged tool or screwdriver to remove them from the bearing housing. Be careful not to damage the shaft (122) or seat.

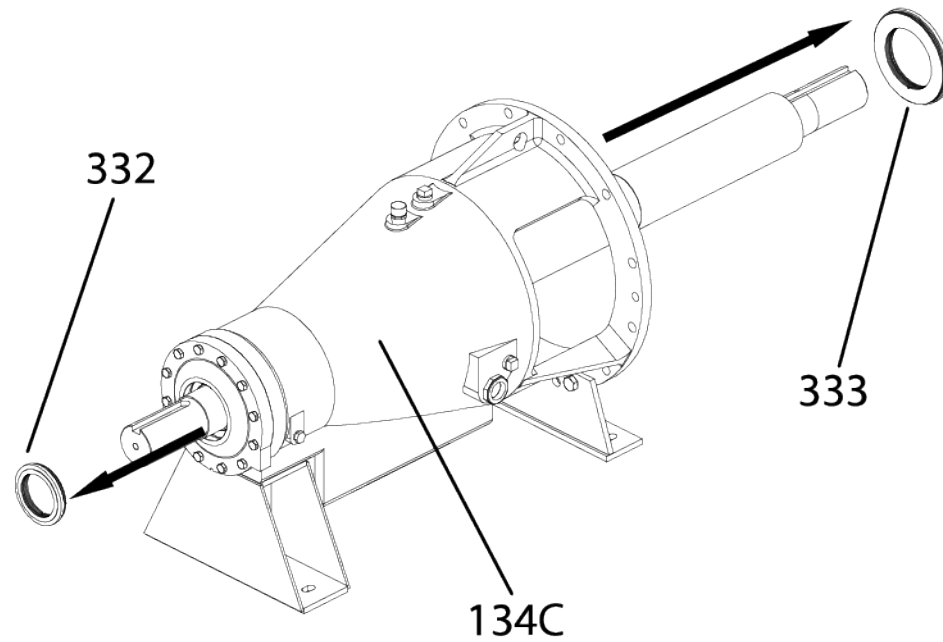

Figure 51: Bearing housing removal

3. Lift the bearing housing up vertically by the drive end using an eyebolt and chain. Be careful not to damage the impeller end of the shaft.
4. Place the bearing housing on a bench or stand so that the shaft protrudes down through it.
5. Remove the screws (799F & 370Y) that secure the front (239B) and rear feet (239A).
6. Remove the screws (788Z) that secure the thrust bearing retainer (119C) to the bearing housing.
7. Remove the retainer and discard the gasket/shims (331) or o-ring (412Y).

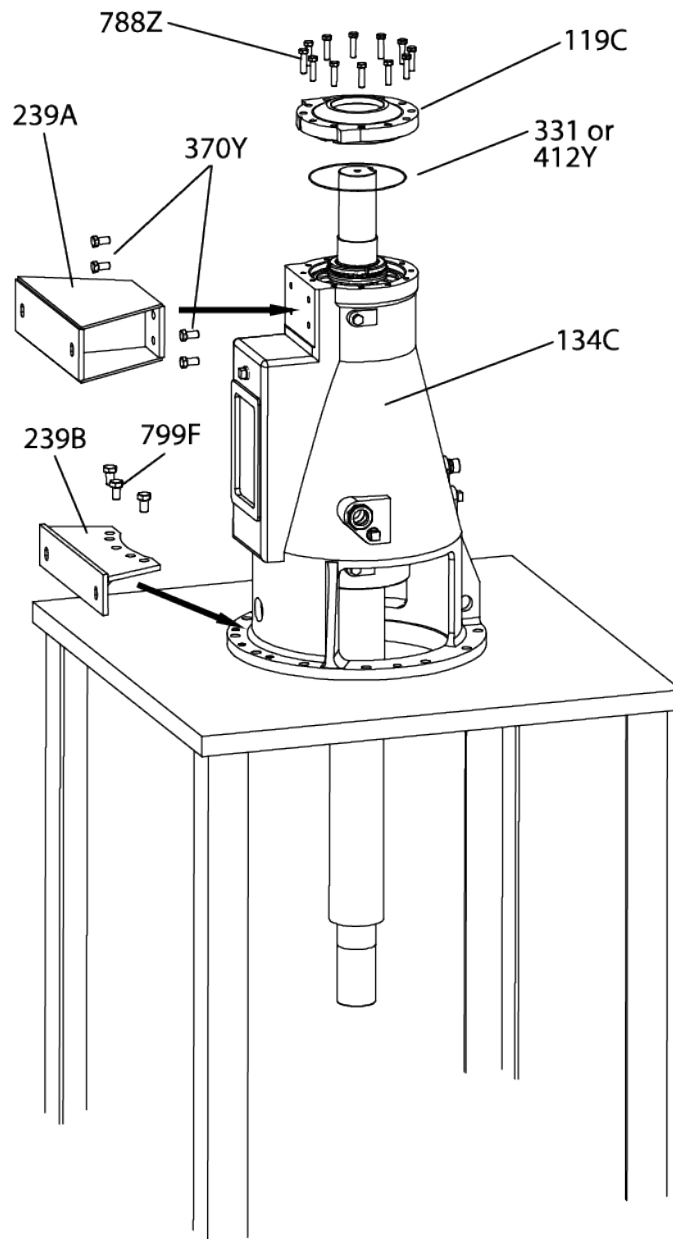

Figure 52: Retainer removal

8. Using the eye bolt already threaded into the shaft, pull the rotating assembly from the bearing housing.

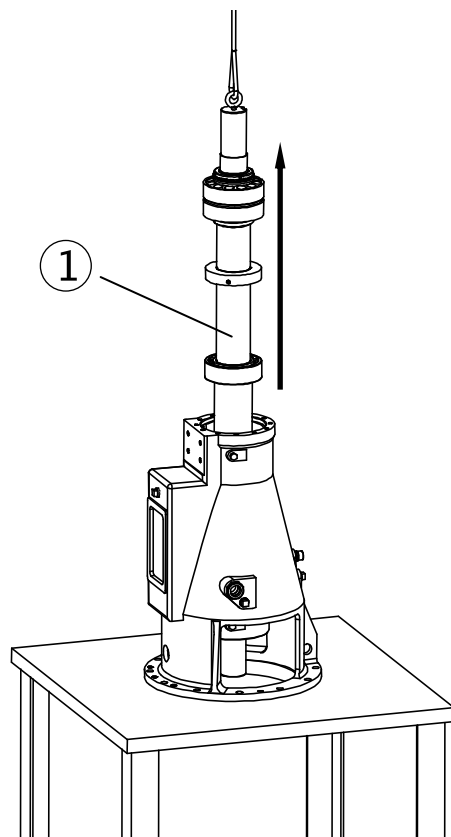

Figure 53: Pull rotating assembly from bearing assembly

9. Once the rotating assembly has been removed place it on a set of wooden V-blocks for bearing removal.

Remove the bearing (1MXR-3MXR configuration)

1. In order to remove the bearings first pry the tangs of the lock-washer (382) from the lock-nut (136).
2. Using a spanner wrench remove the lock-nut (136) and lockwasher (382).
This thrust bearing configuration consists of two back to back angular contact bearings.
3. Use a bearing puller to remove both thrust bearings (112C).
4. Use a puller to remove the inboard radial bearing (168C) from the opposite end of the shaft.
Be careful not to damage the shaft.

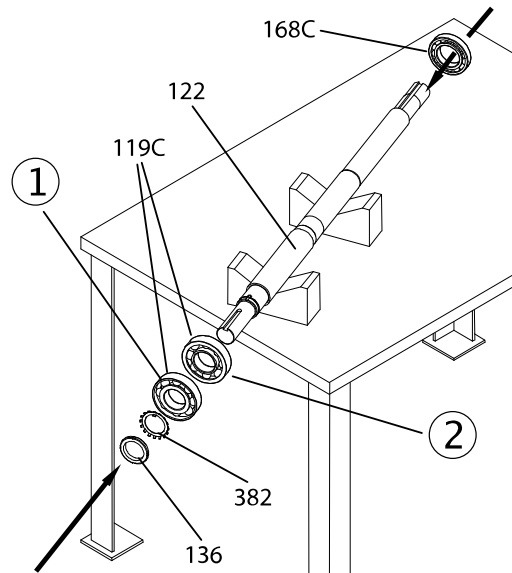

Figure 54: 1MXR-3MXR rotating element

Remove the bearing (4MXR-6MXR configuration)

1. In order to remove the bearings first pry the tangs of the lock-washer (382) from the lock-nut (136).
2. Use a spanner wrench to remove the lock-nut (136) and lockwasher (382).
3. Slide off the keyed washer (142B).
This thrust bearing configuration is an indirectly mounted taper roller bearing.
4. Use a bearing puller to remove the thrust bearing (112C).
5. Remove the thrust bearing collar (443X) and oil wheel (248).
The oil wheel has one to three set screws (222N) that hold it to the shaft (122). The collar and oil wheel must be removed prior to removing the inboard bearing.
6. Use a puller to remove the inboard radial bearing (168C) from the drive end of the shaft.
Be careful not to damage the shaft.

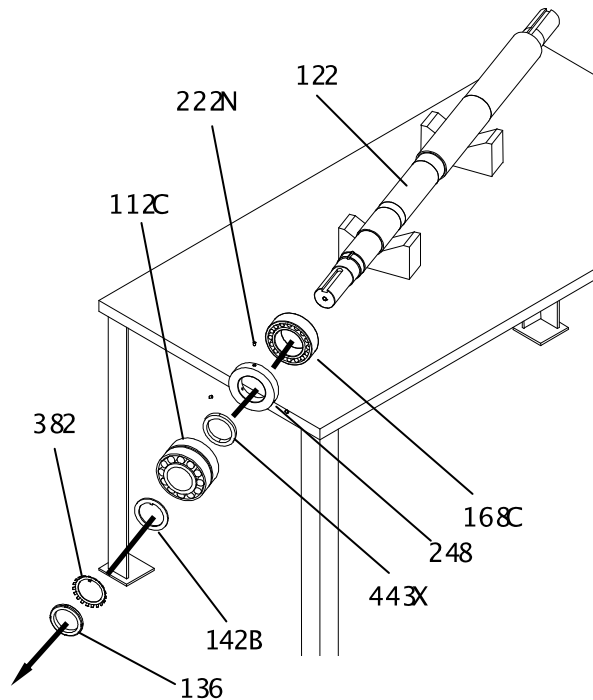

Figure 55: 4MXR-6MXR rotating element

Disassemble the cooling coil (optional) sight glass / breather and plugs

1. Loosen and remove the screws (370F) that secure the cover plate (113B) to the bearing housing (134C) and discard the gasket. (360E).
2. Remove the cover plate and coil. Disconnect the connectors (972G and 972H) from the cover plate and remove the cooling coil (984A).

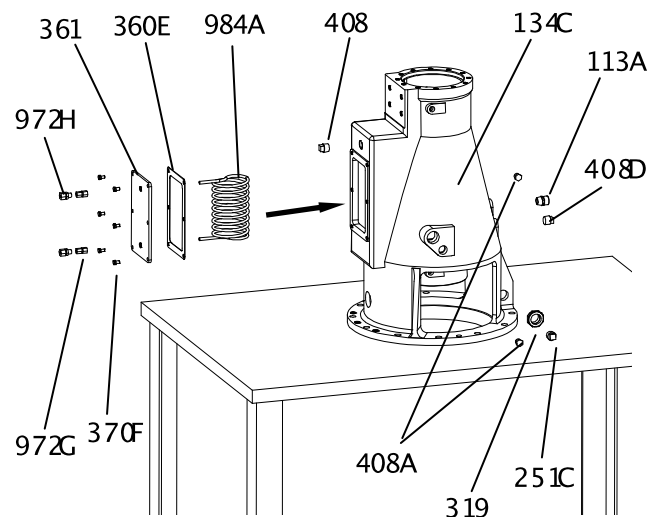

Figure 56: Removal of optional cooling coil

3. If necessary remove the breather (113A), pipe plugs (408D, 408, 408A, 251C) and the sight glass (319).

Pre-assembly inspections

Guidelines

Before you assemble the pump parts, make sure you follow these guidelines:

- Inspect the pump parts according to the information in these pre-assembly topics before you reassemble your pump. Replace any part that does not meet the required criteria.
- Make sure that the parts are clean. Clean the pump parts in solvent in order to remove oil, grease, and dirt.

NOTICE:

Protect machined surfaces while you clean the parts. Failure to do so may result in equipment damage.

Inspect the elbow / casing / liner (options)

The elbow and or casing (315A or 100) and liner (103A) should be inspected for excessive wear or pitting in the impeller and gasket areas. They should be repaired or replaced if wear or corrosion exceeds the following criteria.

1. Inspect for localized wear or grooving greater than 3.2mm | 1/8 in. deep.
2. Inspect for pitting greater than 3.2mm | 1/8 in. deep.
3. Inspect case gasket seat surface for irregularities.

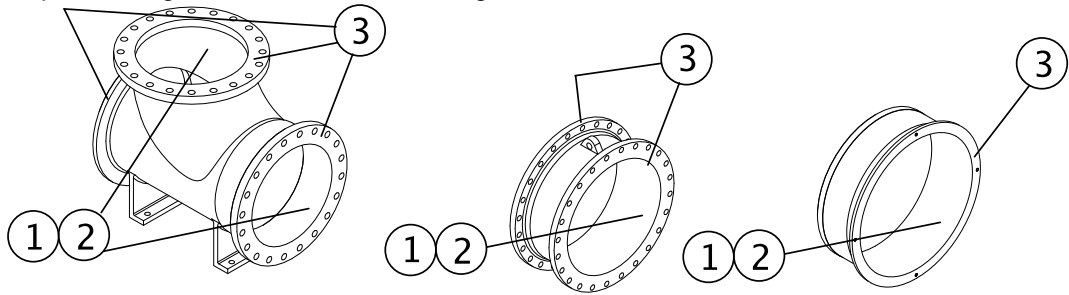

Inspect impeller vane

1. Inspect impeller vanes for damage (101). Check the vane O.D. for erosion. Check the vane surfaces, replace if grooved, worn, or eroded deeper than 5.0mm | 3/16". Excessive impeller wear may cause a reduction in performance.

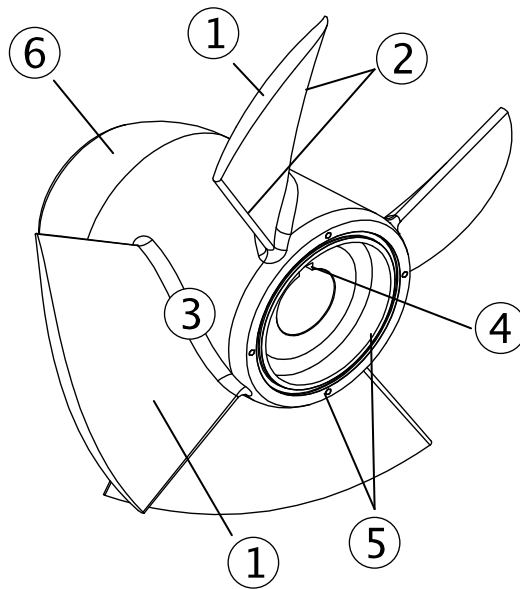

Figure 57: Impeller inspection

2. Inspect the leading and trailing edges of the vanes for pitting, erosion or corrosion damage replace if grooved, or worn deeper than 5.0mm | 3/16".
3. Inspect the root (vane attach point at hub) of each vane for cracks. Impeller vane failure can cause unbalance in the rotating assembly that will lead to catastrophic failure of the pump.
4. Inspect the keyway and stepped bores for signs of pitting, wear or corrosion damage.
5. Check the O-ring groove and bolt holes for signs of pitting or corrosion.

Inspect the shaft

1. Check the shaft (122) for straightness, wear, corrosion, and radial run-out. Maximum run-out for non-contact portions of the shaft is 0.08mm | .003 in. max.

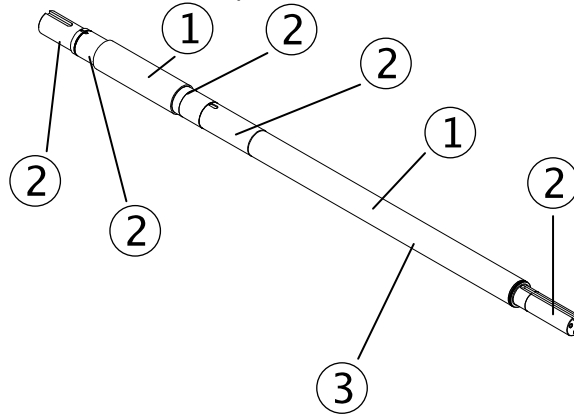
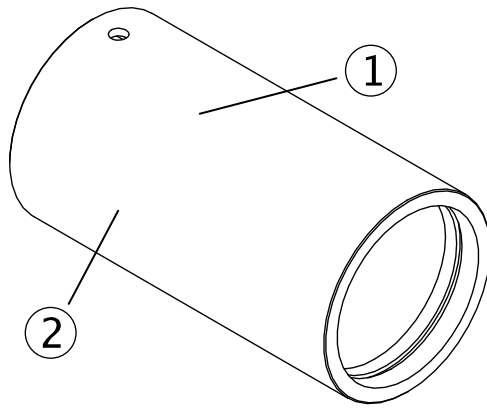

Figure 58: Shaft inspection

2. 2. For all contacting surfaces such as bearing seats, sleeve seats, and impeller mounting surfaces see critical axial flow table.

Inspect the shaft sleeve

1. The shaft sleeve (126) should be replaced if badly grooved or worn. Localized wear or grooving greater than 2.4 mm | 3/32 in. deep is cause for replacement.



Inspect the mechanical seal / restrictor bushing

1. Refer to the mechanical seal (383) vendor's manual for inspection instructions.
2. The restrictor bushing, (496B) if necessary should be replaced during re-assembly.

Inspect the stuffing box (packed pumps only)

1. Check the stuffing box (220) for localized wear or grooving greater than 1.6 mm | 1/16 in. deep.
2. Check for pitting greater than 3.2mm | 1/16 in. deep.
3. Inspect stuffing box gasket seat surface for any irregularities.

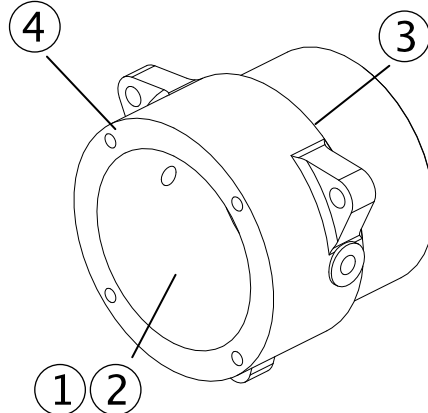
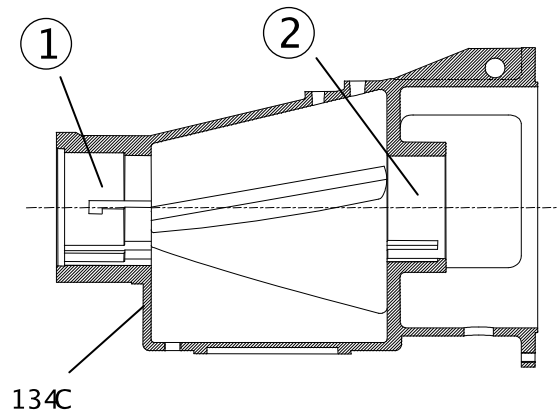

Figure 59: Inspect the stuffing box

Inspect the bearing housing

1. Inspect the bearing housing (134C) bores for signs of scarring or galling from the outer race.
2. Refer to Critical bore dimensions table for the critical bore dimensions for the housings. The bores should not be egg and should be concentric



1 Outer housing bore

2 Inboard housing bore

Figure 60: Bearing housing inspection

Inspect the bearings

1. Inspect the bearings (112C and 168C) for contamination and damage. The condition of the bearing will provide useful information on operating conditions in the bearing housing.
2. Note the lubrication condition and residue.
3. Investigate bearing damage to determine the cause.
4. If cause is not normal wear, correct before the pump is returned to service.
DO NOT RE-USE BEARINGS.

Labyrinth seals and O-rings

Although the labyrinth seals (332, 333), O-rings (351, 351A, 351W, 412A, 412D, 412T, 412Y, 496D) and gaskets (331, 351A, 351W, 211) may seem okay during inspection and examination, **DO NOT RE-USE SEALS** when rebuilding the pump. Replace them while pump is disassembled.

Critical axial flow dimensions and tolerances

Pump Size	Inboard Housing Bore	Outboard housing bore	Inboard bearing seat	Outboard bearing seat	Mech. Seal Seat	Sleeve Seat	Impeller End	
							1st Step	2nd Step
6	3.5442 3.5433	3.9379 3.9370	1.9690 1.9686	1.7722 1.7718	1.750 1.748	1.687 1.685	1.2495 1.2485	
8							1.3745	
10							1.3735	
12	4.7253 4.7244	5.5128 5.5118	2.5597 2.5592	2.5597 2.5592	2.500 2.498	2.437 2.435	1.9995	2.0307
14							1.9985	2.0297
16	5.9076 5.9055	6.6950 6.6929	3.3472 3.3466	3.1502 3.1497	3.250 3.248	3.248 3.247	1.9895	1.9995
18							1.9885	1.9985
20							2.5935	2.6245
24	7.8758 7.8740	8.3780 8.3770	4.7263 4.7254	4.2531 4.2521	5.250 5.248	5.188 5.186	2.5925	2.6235
							2.6245	2.6555
700mm	9.8449	10.7530	5.9071	4.7534	6.250	6.187	3.6240	3.6552
30	9.8431	10.7520	5.9061	4.7524	6.248	6.186	3.6230	3.6542
36	11.0262 11.0244	12.0030 12.0020	6.6945 6.6935	5.7525 5.7515	7.000 6.998	6.9360 6.9335	4.0000	4.0300
							3.9985	4.0290
36	11.0262 11.0244	12.0030 12.0020	6.6945 6.6935	5.7525 5.7515	7.000 6.998	6.9360 6.9335	3.999	
							3.998	
36	11.0262 11.0244	12.0030 12.0020	6.6945 6.6935	5.7525 5.7515	7.000 6.998	6.9360 6.9335	4.7180	4.7490
							4.7165	4.7475

Maximum bolt torque values N-M | Ft-Lb

Table 9: Maximum bolt torque table

Sizes	Cold Drawn Steel ASTM A108 Grade 1213		316 Stainless Steel ASTM A276 Type 316		Cold Drawn Alloy Steel ASTM A193 Grade B7	
	Lubricated	Dry	Lubricated	Dry	Lubricated	Dry
5/16-18	6 4	9 6	9 6	13 9	14 10	23 17
3/8-16	9 6	13 9	15 11	23 17	25 18	37 27
1/2-13	21 15	31 23	37 27	55 41	40 29	59 44
5/8-11	41 30	62 45	74 54	110 81	60 44	90 66
3/4-10	72 53	108 80	90 66	135 99	118 87	129 95
7/8-9	116 85	174 128	144 106	216 159	209 154	177 131
1-8	174 128	261 192	216 159	324 239	504 371	755 557
1 1/2-6	600 443	1200 885	500 369	745 550	1859 1371	2789 2057

Reassembly

Reassemble the cooling coil (optional) sight glass / breather and plugs

Re-assembly of the AF is done opposite the order of disassembly with a few exceptions. Be sure the parts are clean and free of burrs and scratches. Every assembly step should be double-checked to ensure proper order and technique to prevent having to partially disassemble the step you just finished.

1. The optional cooling coil is installed by first fastening two modified male connectors (972G) to the cooling coil cover (113B).
2. Insert the ends of the cooling coil (984A) through the male connectors (972G) and screw the female connector (972H) to the male compressing the tubing in-between.
3. Attach the cover plate (113B) to the bearing housing (134C) using a new gasket (360E) and the six screws (370F) w/ O-rings (496D).

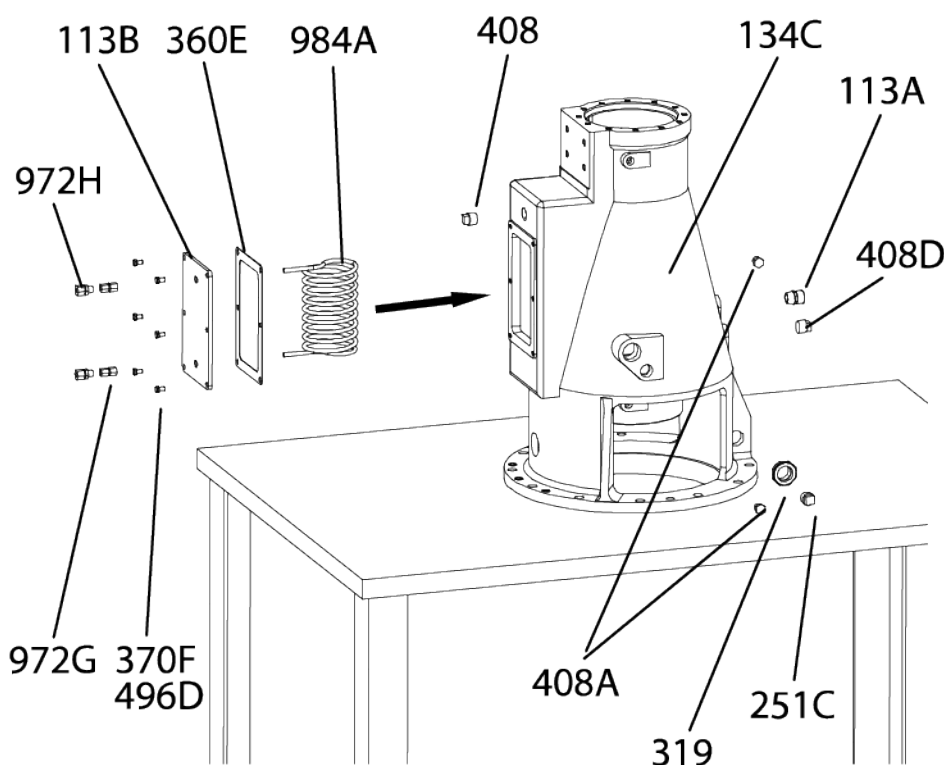

Figure 61: Cooling coil reassembly

4. Install the breather (113A), pipe plugs (408, 408A, 408D, 251C) and sight glass (319) in the locations shown in Cooling coil reassembly figure.

Reassemble the rotating element (1MXR-3MXR configurations)

1. Heat the inboard radial bearing (168C) to 107°C | 225°F using an induction heater.
2. Slide the bearing onto the impeller end of the shaft (122), push it on until it rests flush and square against the shaft shoulder, see figure below and the sectional drawing at the end of this section.

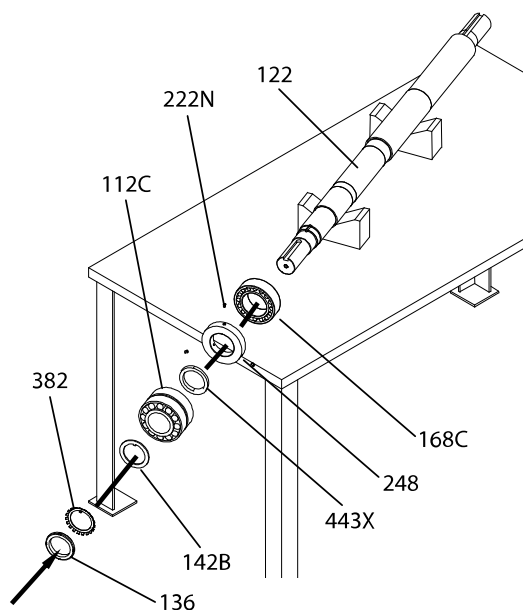

Figure 63: Rotating element reassembly (4MXR-6MXR configurations)



WARNING:

Wear insulated gloves when you use a bearing heater. Bearings get hot and can cause physical injury.

2. Install the oil wheel (248) by sliding it onto the shaft with the open end facing the inboard bearing (168C). With the oil wheel up against its shoulder install the set screws (222N) that hold it to the shaft (122).
3. Heat may be applied to the thrust bearing collar (443X) if necessary to install on the shaft. Install it with the tapered end facing the oil wheel (248).
4. Heat the thrust bearing (112C) to 107°C | 225°F. Install one row of roller bearings and the inner race on the shaft (122). Be sure to slide the bearing on the shaft until it is flush and square up against the thrust bearing collar (443X).
5. While the thrust bearing is still hot install the outer row of rollers and the outer race. Install the keyed washer (142B), lock-washer (382) with its tang in the groove on the shaft (122) and the lock nut (136) with tapered end toward the lock washer (382). Tighten the whole unit until snug. Re-tighten the lock nut (136) several times before the bearing cools completely. Be sure no clearance exists between the inner race, collar (443X) and shaft shoulder (122). With the locknut secure align the slots with the tangs of the lock-washer and bend the lock washer tangs into the nut slots.
6. If the pump is grease lubricated pack the inboard (168C) and outboard bearings (112C) with suitable grease. Make sure the races are fully packed.

Reassemble the bearing housing

1. Thread an eyebolt into the end of the shaft (122), lift and lower the rotating element into the bearing housing (134C), see Figure: *Bearing housing insertion*, below. A collar similar to that shown on pg. 69 should be used to prevent misalignment of the inboard radial bearing.

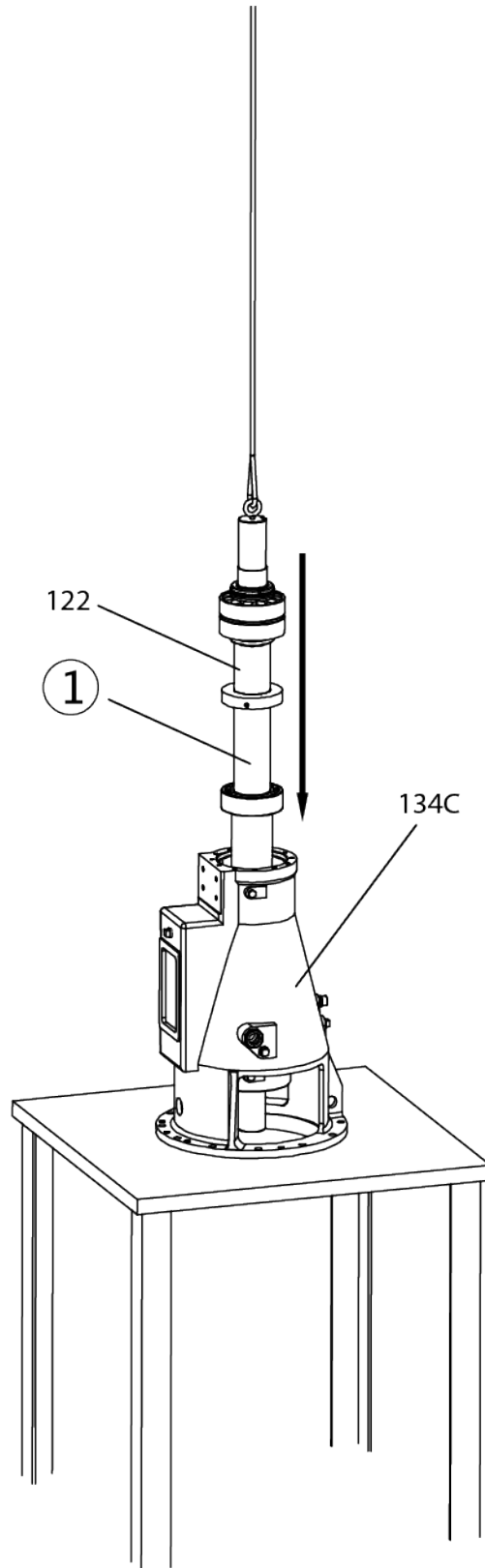

1. Rotating element

Figure 64: Bearing housing insertion

2. Using screws (799F & 370Y), install the front (239B) and rear feet (239A).

3. Install the thrust bearing retainer (119C), O-ring (412Y) (4MXR ~ 6MXR) or gaskets (331) (1MXR~ 3MXR).
See the assembly drawing for proper shimming of gasketed pumps. Install the screws (788Z) that secure the thrust bearing retainer (119C) to the bearing housing (134C).

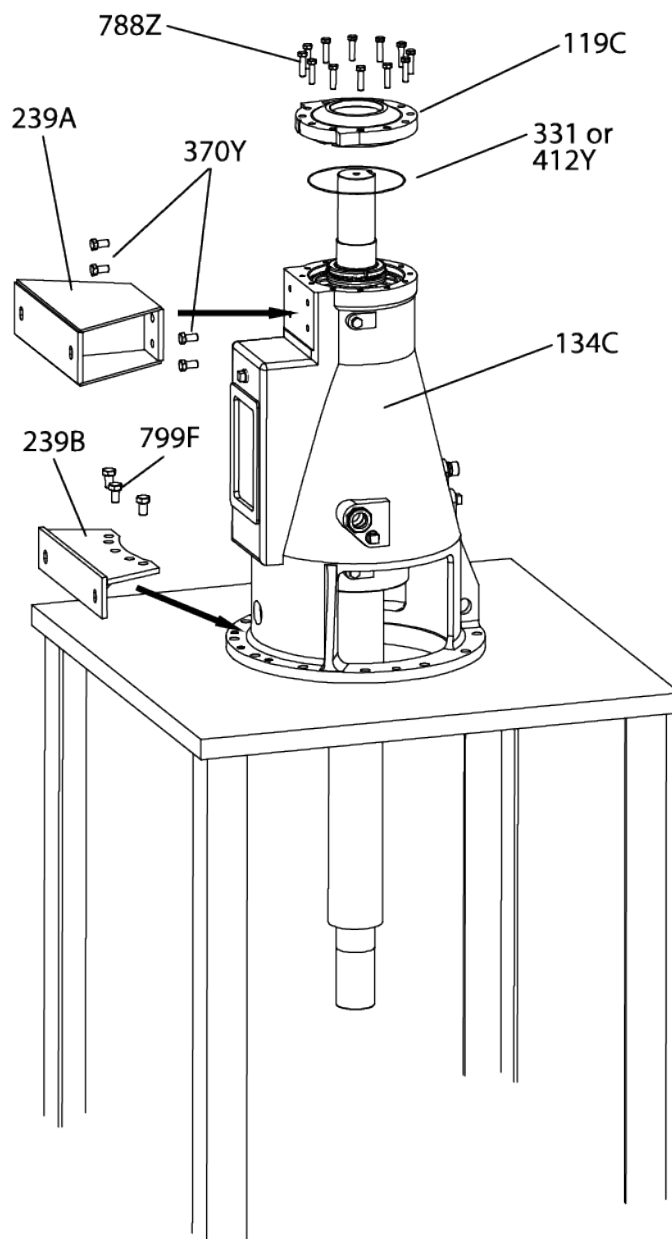

Figure 65: Reassemble the bearing housing

4. Install the outboard and inboard labyrinth seals (132) and (133).
The drains should be located at the bottom and face inward when mounted.

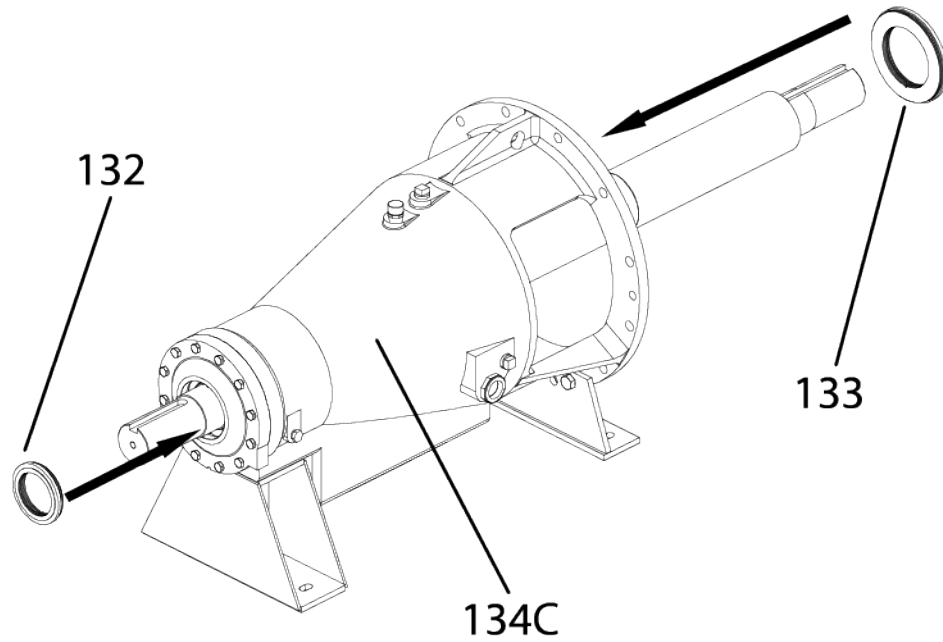

Figure 66: Labyrinth seal reassembly

Reassemble the drip pan

1. Tilt the drip pan (179) so the attachment ears clear the bearing housing (134C) flange and the nipple protrudes through the cast hole in the bottom of the bearing housing.
2. Secure the drip pan to the bearing housing ribs using the two screws (799H) and washers (799I).
3. Thread the street elbow (799G) into nipple on the bottom of the drip pan.

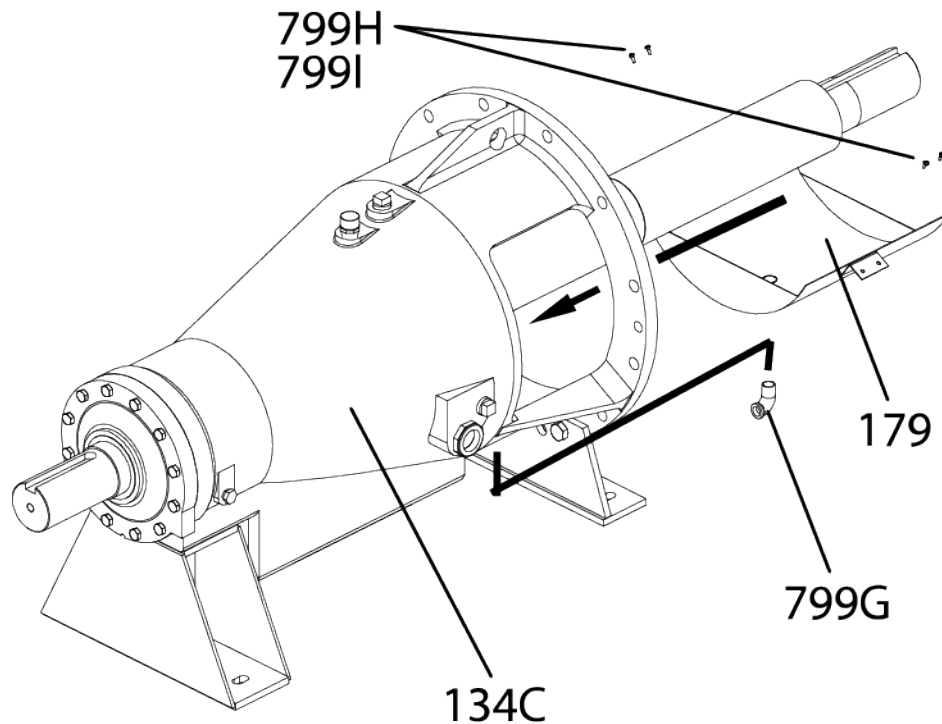

Figure 67: Drip pan reassembly

Reassemble the packed box (cast back-pullout design only)

1. Place the sleeve key (178D) into the shaft (122) key seat. Slip the O-ring (412D) into the shaft sleeve (126) then slide the sleeve onto the shaft until the keyways are lined up.
2. Install the set screw (469D) and tighten it to lock the sleeve in place.
Be careful not to mar or scratch the sleeve or shaft during the process.
3. Attach the stuffing box (220) and gasket (351W) to the stuffing box cover (184) using screws (799E).
If removed re-install the four studs (355). On larger pumps use a sling or hook and chain to support the weight of the stuffing box cover during installation.
4. Mount the stuffing box cover (184) to the register of the bearing housing (134C).
Be careful not to scuff or scar the pump shaft (122) or sleeve (126) during installation.
5. Secure the stuffing box cover (184) to the bearing housing (134C) using bolts (370C).
6. Pack the stuffing box initially with two rings of packing (106) staggering the joints for each row. Insert the lantern ring (105) being sure that the lantern ring lines up with the flush ports.
If the lantern ring has taps for removal make sure they face out of the box.
7. Insert three more rings of packing (106), gland (107), and gland nuts (353), tighten the nuts only hand tight.
8. Install all flush tubing that may have been removed during disassembly.

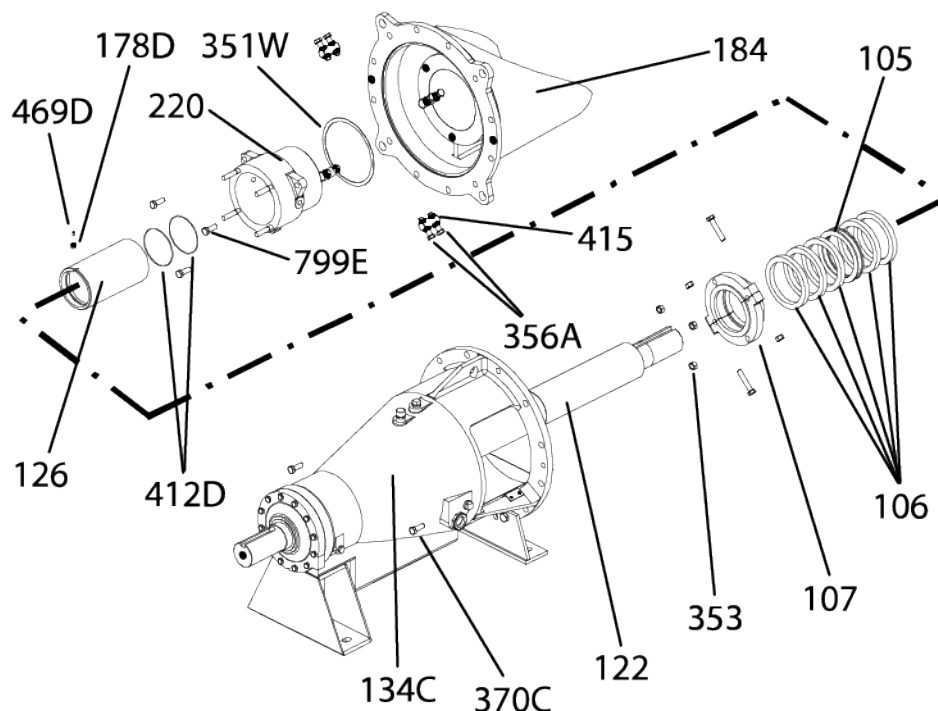

Figure 68: Packed box reassembly

Reassembly of the Packing Chamber (Fabricated Elbow Design only)

If pump was supplied with packing, reassemble the Packing Chamber and Packing.

1. Place the sleeve key (178D) into the shaft (122) key seat. Slip the O-ring (412D) into the shaft sleeve (126) then slide the sleeve onto the shaft until the keyways are lined up.
2. Install the set screw (469D) and tighten it to lock the sleeve in place. Be careful not to mark or scratch the sleeve or shaft during the process.
3. Install the packing chamber (220) and O-ring (351W) onto the shaft sleeve.

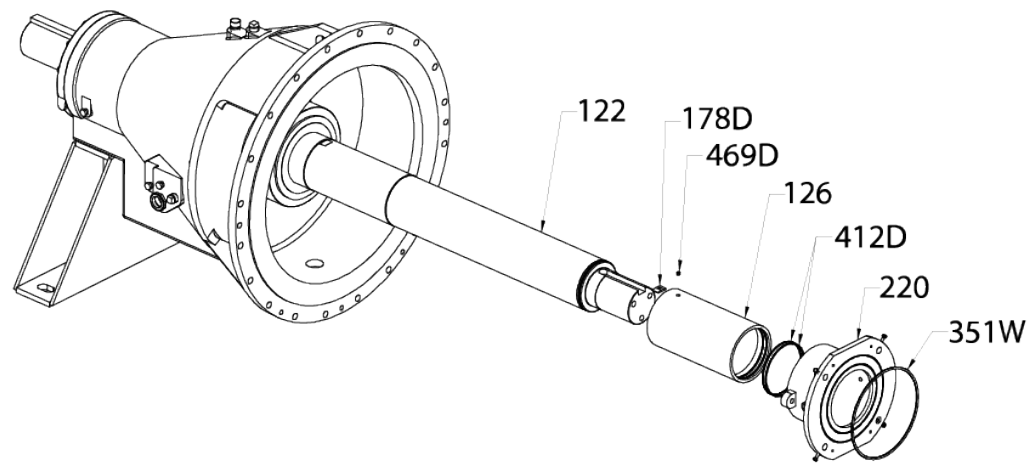

Figure 69: Installation of shaft sleeve and packing chamber onto shaft

Reassemble the mechanical seal with optional adapter (cast back-pullout design only)

The loose mechanical seal (383, 108) components and gaskets (211) are slid onto the shaft (122) first before the stuffing box cover (184) can be installed. If the seal includes a restrictor bushing (496B) an optional adapter (108B) will be included with the pump.

1. On large pumps use a sling or hook and chain to securely support the weight of the stuffing box cover during installation.
2. Mount the stuffing box cover on the bearing housing (134C) register.
3. Secure the stuffing box cover (184) to the bearing housing (134C) using two bolts (370C). Be careful not to scuff or mar the pump shaft (122) during installation.
4. Install the four adjusting lugs (415) and impeller adjusting bolts (356A).
5. Use the upper adjusting screws (356A) closest to the bearing housing to center the stuffing box cover on the shaft.

The seal manufacturers instructions should be followed to correctly install and align the mechanical seal.

6. Lastly, install the seal gland nuts (353) and secure the seal to the stuffing box cover (184). Be sure all gland quench or flush tubing is connected.

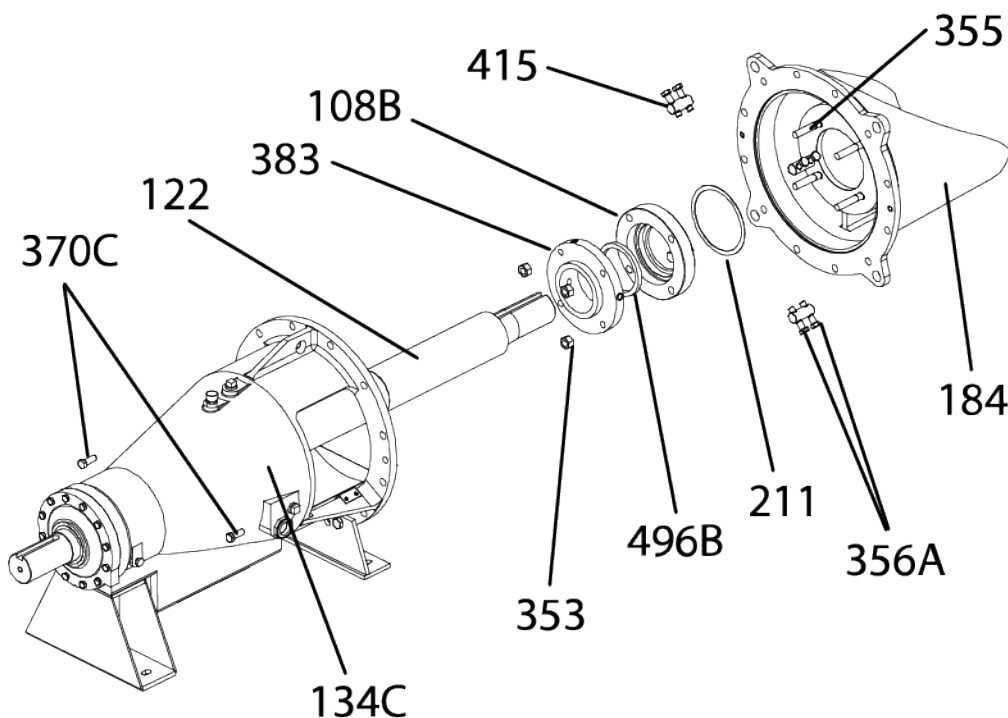

Figure 70: Mechanical seal with optional adapter reassembly

Reassembly of the Mechanical Seal (Fabricated Elbow Design only)

If pump was supplied with a mechanical seal, reassemble the Mechanical Seal and Mechanical Seal Adapter.

1. Slide the mechanical seal (383) components and gaskets onto the shaft (122).
2. If the seal includes a restrictor bushing (496B) or an optional adapter (108B), slide those onto the shaft.
3. Slide the mechanical seal adapter (108D) and O-ring (497S) onto the shaft.

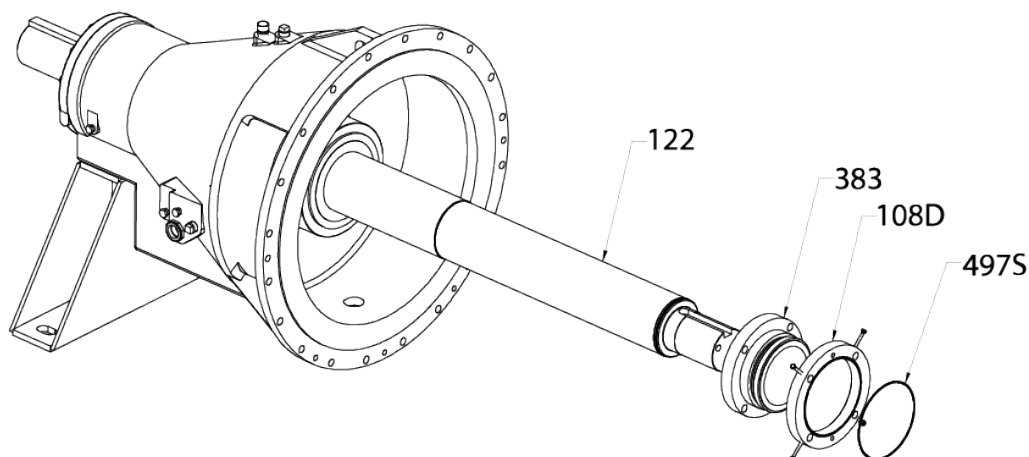

Figure 71: Mechanical seal, optional restrictor bushing, optional adapter, and mechanical seal adapter installation onto shaft

Reassembly of Cast Back-Pullout Pumps Only

Reassemble the standard impeller

If your model has a standard impeller, follow the steps below:

1. Install the shaft key (178).
2. Slide the impeller (101) onto the shaft (122) and if necessary use a wooden mallet to set it in place against the shaft shoulder.
3. Install the shaft washer (199) and fasteners (198), tighten to lock the impeller (101) in place, see Figure: *Standard impeller reassembly* below.

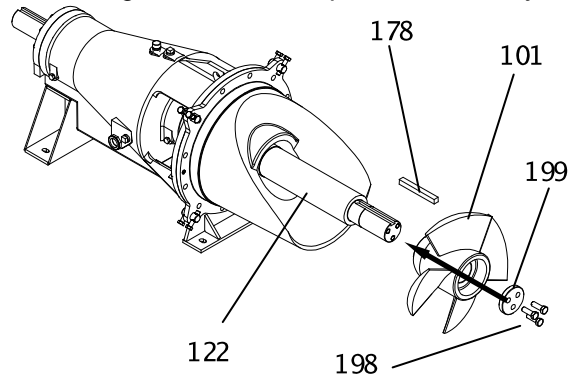

Figure 72: Standard impeller reassembly

Reassemble the sealed impeller (cast back-pullout design only)

If you have a sealed impeller, follow the steps below:

1. 700mm and 36" sizes use an impeller cover and O-rings to keep pumpage out of the impeller cavity. First, install the shaft key (178) on the shaft. Using some silicone stick the impeller O-ring (412A) to the back side of the impeller (101).
2. Slide the impeller (101) onto the shaft (122). If necessary use a wooden mallet to set it in place against the shaft shoulder.
3. Install the shaft washer (199) and bolts (198).
4. Place the O-ring (412T) on the cover and fasten the cover (998E) to the impeller (101) using bolts (370M).
Some impeller covers have a pipe test plug (408H) located on the face of the cover to test the cavity seal after re-assembly.
5. Re-install this plug (358I).

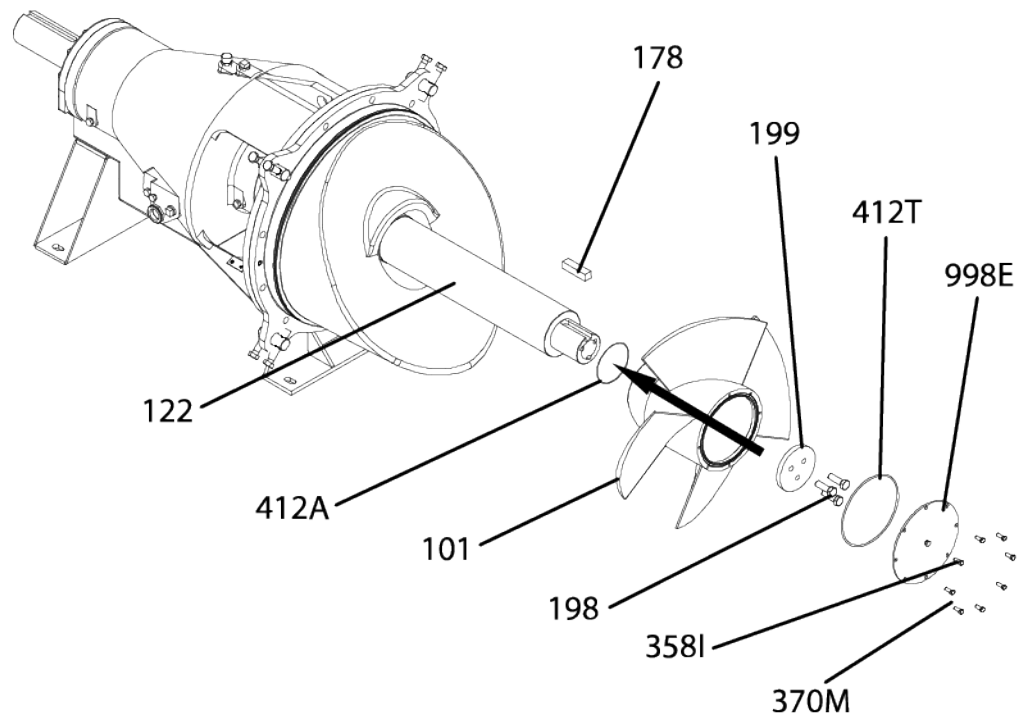
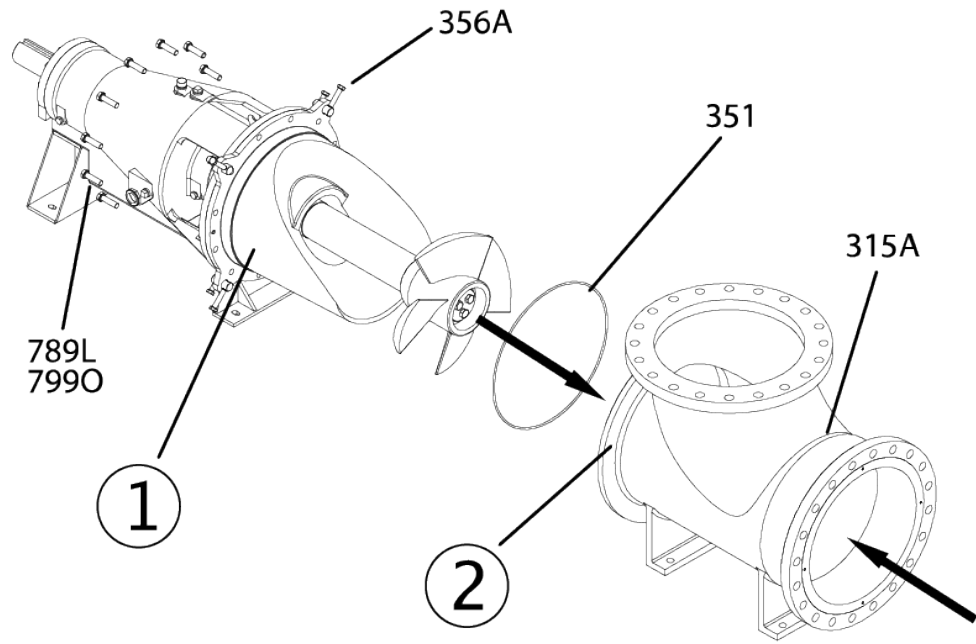

Figure 73: Sealed impeller reassembly

Reassemble the back-pullout elbow (cast back-pullout design only)

1. Set the pump down on a smooth flat surface to stabilize it for assembly.
2. Loosen the impeller adjusting bolts (356A) so that they are clear of the rear elbow flange.
3. With the elbow held in place, slide the back-pullout into the elbow (315A).
4. Install the bolts (789L and 799O) that secure the back-pullout to the elbow (315A).
Be sure to use the correct O-ring material for the pumpage.



1. Back pull-out
2. Rear elbow flange

Figure 74: Elbow reassembly

5. Before tightening the bolts (789L and 799O), adjust elbow to center the impeller using adjusting bolts (356A).
6. After impeller is centered, tighten the bolts (789L and 799O).

Reassemble the back-pullout elbow with casing

1. The 700mm & 36" size pumps come with a separate casing (100). Loosen the adjusting screws (356A) so that they are clear of the elbow flange.
2. Insert O-ring (351) into the elbow groove and hold in place with a small amount of grease. Be sure to use the correct O-ring material for the pumpage.
3. With the elbow fixed, slide the back-pullout into the elbow (315A) and install bolts (789L and 799O).
4. Insert the O-ring or gasket (351A) between the casing (100) and elbow (315A).
5. Attach the casing (100) to the elbow (315A) using the bolts (799C) and nuts (799D).
6. With casing (100) slightly loose adjust casing to center the impeller.

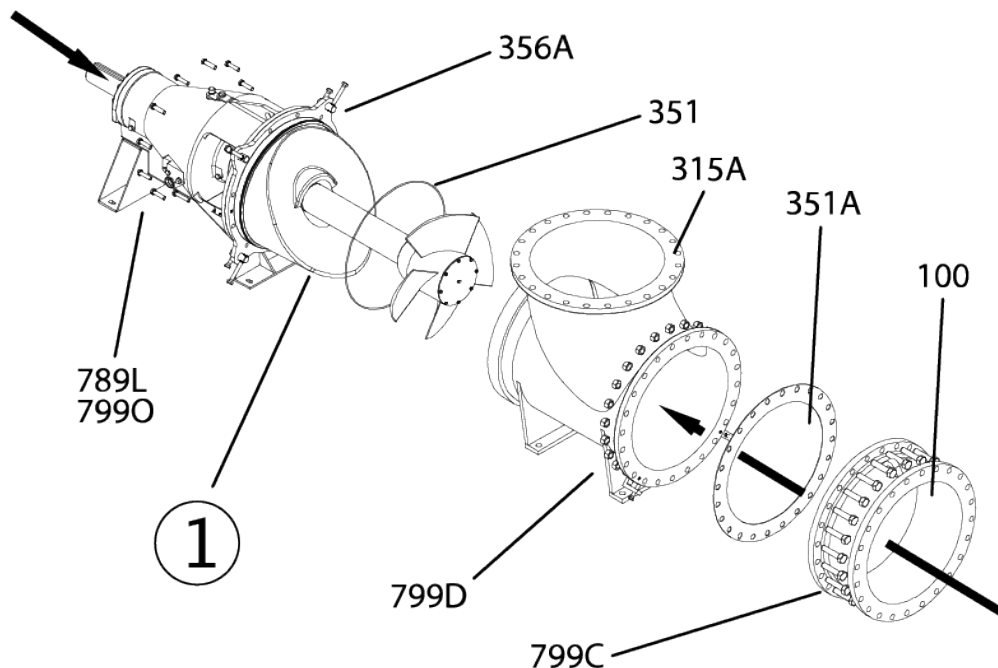

1. Back-pullout

Figure 75: Elbow with casing reassembly

Reassemble the back-pullout liner (option)

1. If the elbow (100) or casing (100) has an optional liner (103A) now is the time to install it. The liner may require some effort to install try using a wooden mallet if resistance is noticed. The liner is sealed when it is compressed against the pipe flange and requires no gasket. If a replacement is necessary be sure to order the correct material for the pumpage.

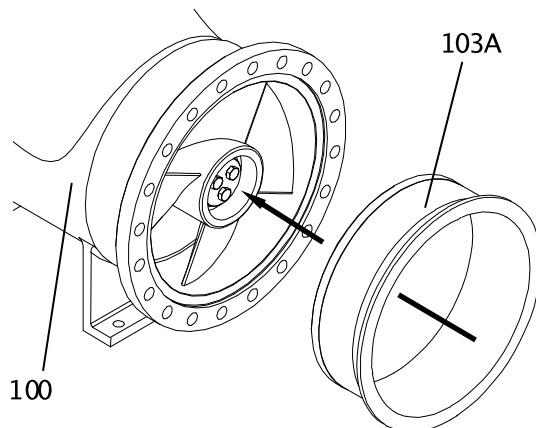

Figure 76: Liner (option) reassembly

Reassembly of Fabricated Non Back-Pullout Pumps

Reassemble the Elbow (Fabricated Elbow Design Only)

1. Set the Fabricated Elbow down onto a flat surface to stabilize it for assembly.
2. Loosen the impeller adjusting bolts (356A).
3. With the Fabricated Elbow held in place, slide the power end into the elbow (315A).
4. Install the bolts (356E & 799O) and nuts (357A) that secure the power end to the elbow but do not fully tighten them.

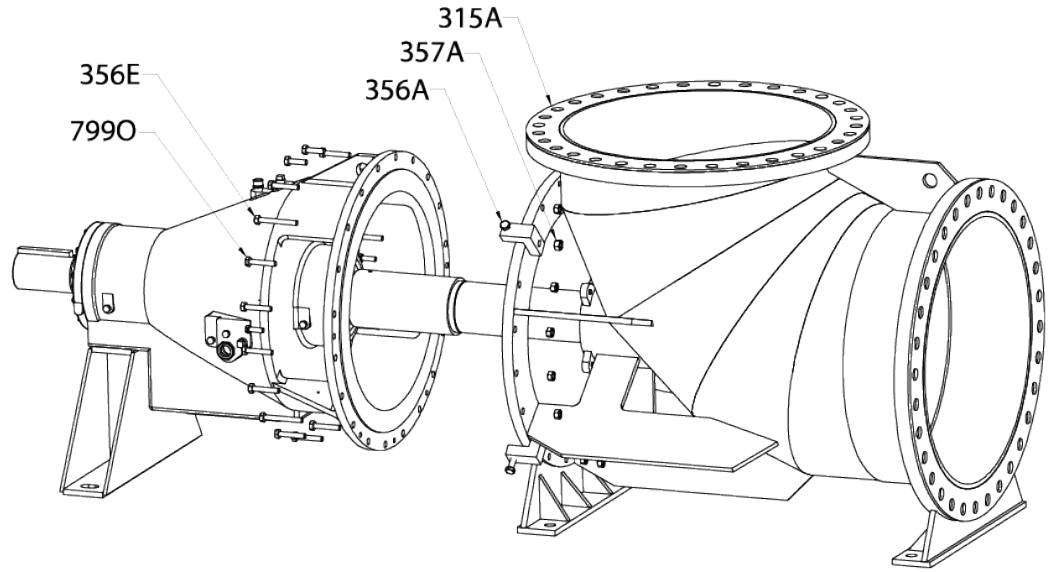

Figure 77: Elbow reassembly

Reassemble the Standard Impeller (Fabricated Elbow Design Only)

1. Install the impeller key (178).
2. Slide the impeller (101) onto the shaft (122) using the Goulds impeller assembly tool or some other device. Refer to instructions on use of the Goulds impeller assembly tool in Appendix II. If necessary use a wooden mallet to set it in place against the shaft shoulder.
3. Install the shaft washer (199) and fasteners (198), tighten to lock the impeller (101) in place.

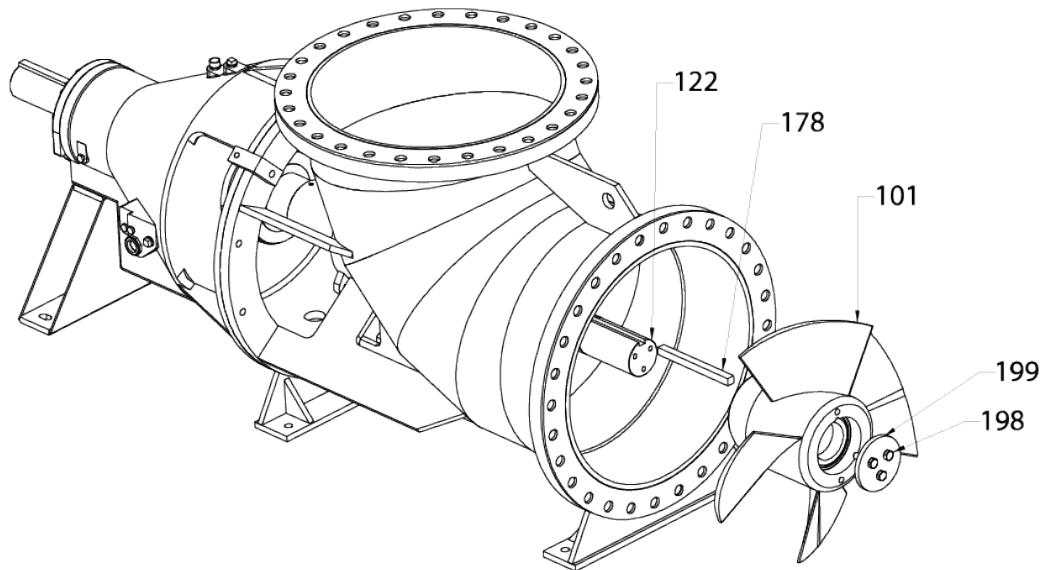

Figure 78: Reassemble standard impeller

Reassemble the Sealed Impeller (Fabricated Elbow Design Only)

700mm and 36" sizes use an impeller cover and O-rings to keep pumpage out of the impeller cavity

1. Install the impeller key (178) on the shaft. Using silicone attach the impeller O-ring (412A) to the back side of the impeller (101).
2. Slide the impeller (101) onto the shaft (122) using the Goulds impeller assembly tool or some other device. Refer to instructions on use of the Goulds impeller assembly tool in Appendix II. If necessary use a wooden mallet to set it in place against the shaft shoulder.

3. Install the shaft washer (199) and bolts (198).
4. Place the O-ring (412T) on the cover and fasten the cover (998E) to the impeller (101) using bolts (799B).

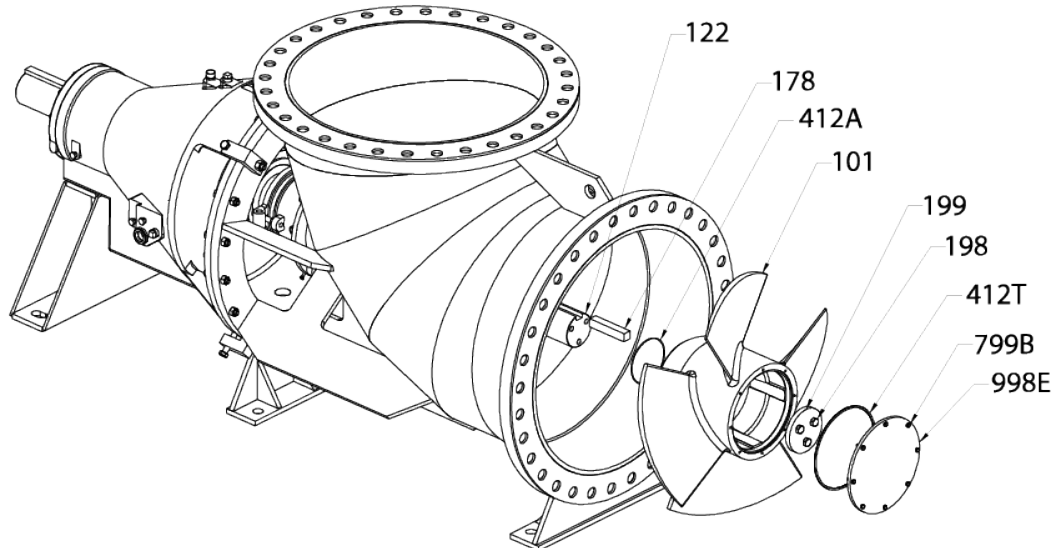

Figure 79: Reassembly of the sealed propeller

Align the Propeller to the Elbow (Fabricated Elbow Design Only)

1. With the elbow to frame bolts (356E and 799O) loosened, align the propeller (101) inside the fabricated elbow (315A) using the elbow adjusting bolts (356A).
2. After the propeller is aligned, tighten the elbow to frame bolts (356E and 799O).

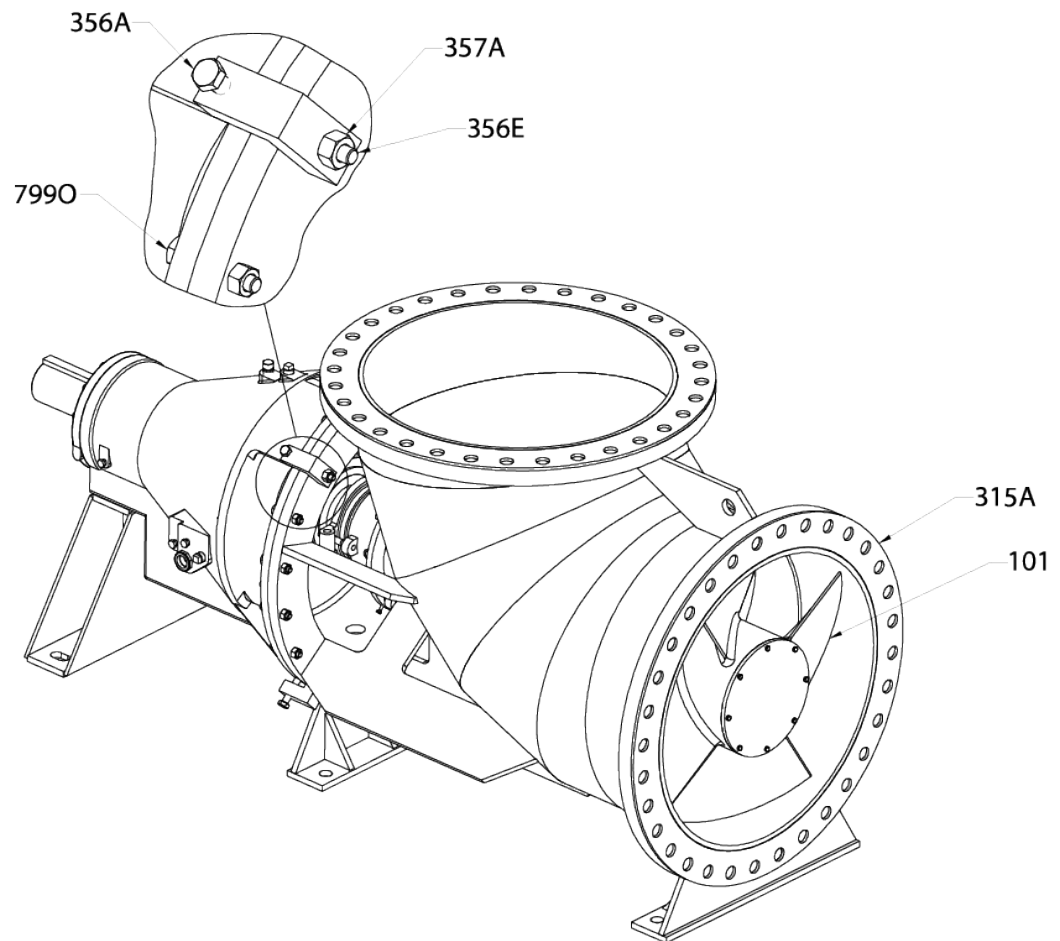

Figure 80: Alignment of propeller to the fabricated elbow

Align the Mechanical Seal Adapter and Install the Mechanical Seal (Fabricated Elbow Design Only)

1. Slide the O-ring (497S) and mechanical seal adapter (108D) to the face of the fabricated elbow (315A).
2. Install the washers (536W) and screws (370) to mount the mechanical seal adapter to the fabricated elbow but do not fully tighten them.
3. Using the mechanical seal adapter adjusting screws (341C) and a dial indicator, align the mechanical seal adapter to the shaft (122).
4. After the mechanical seal adapter is aligned, tighten the mechanical seal adapter screws.
5. Install the gland studs (353) through the mechanical seal adapter and into the fabricated elbow.
6. Slide the mechanical seal (383) to the mechanical seal adapter. The seal manufacturer's instructions should be followed to correctly install and align the mechanical seal.
7. Install the gland nuts (355) and secure the mechanical seal to the elbow. Be sure all gland quench or flush tubing is connected.

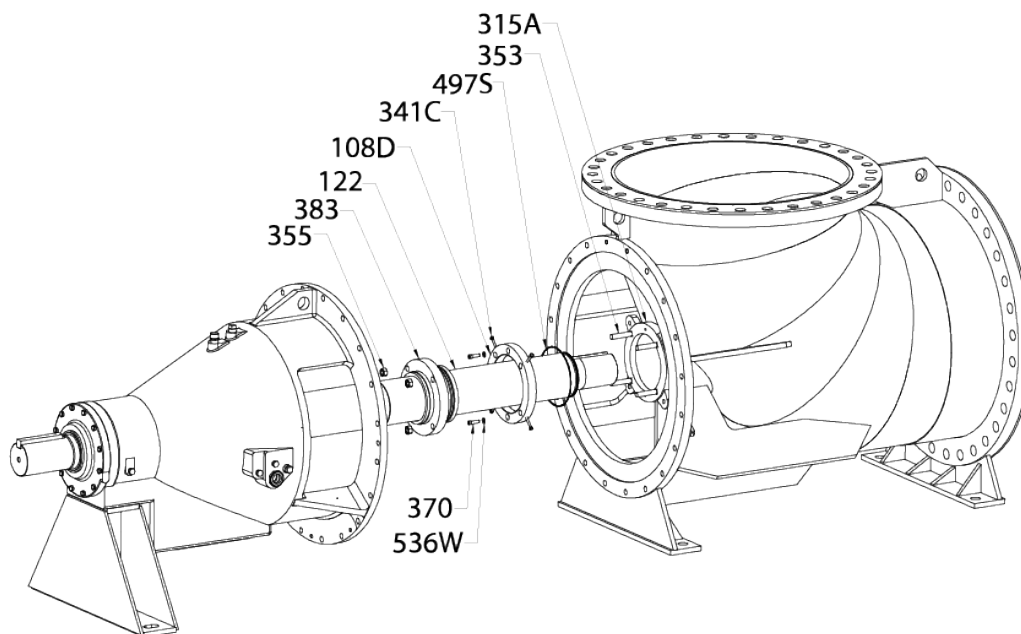

Figure 81: Reassemble and align mechanical seal

Align the Packing Chamber and Install the Packing (Fabricated Elbow Design Only)

1. Slide the packing chamber (220) and O-ring (351W) to the fabricated elbow (315A).
2. Install the packing chamber studs (799E) and nuts (425) into the elbow but do not fully tighten them.
3. Using the packing chamber adjusting screws (341C) and a dial indicator, align the packing chamber to the shaft sleeve (126).
4. After the packing chamber is aligned, tighten the packing chamber.
5. Pack the packing chamber initially with two rings of packing (106), staggering the joints for each row.
6. Insert the lantern ring (105) being sure that the lantern ring lines up with the flush ports. If the lantern ring has taps for removal make sure they face out of the chamber.
7. Insert three more rings of packing (106), staggering the joints for each row.
8. Insert the gland studs (353) into the packing chamber.
9. Insert the packing gland (107) into the packing chamber.
10. Install the gland nuts (355) and tighten.
11. Install all flush tubing that may have been removed during disassembly.

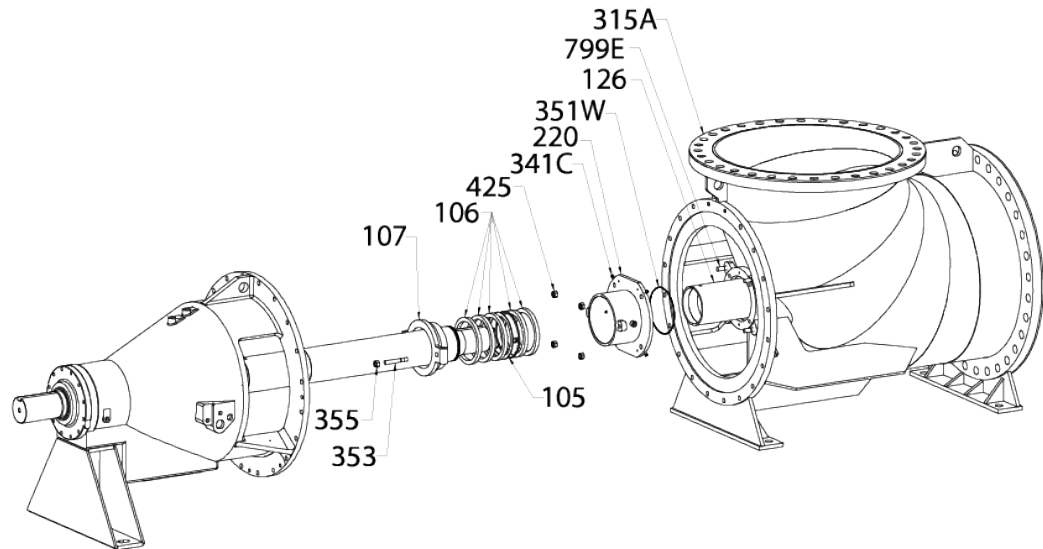

Figure 82: Alignment of packing chamber to the shaft and the gland, packing and lantern ring installation

Reassemble the drive / guard (v-belt configuration)

1. Using a crane, lift the pump into place on the sub-base.
Be careful not to damage the pump by striking any beams or walls that may be near the pump.
2. If any shims were found under the bearing housing feet during disassembly replace them at this time.
3. Install the pump to sub-base bolts (500A) and remove the lifting straps or chains from around the bearing housing (134C) and elbow (100).

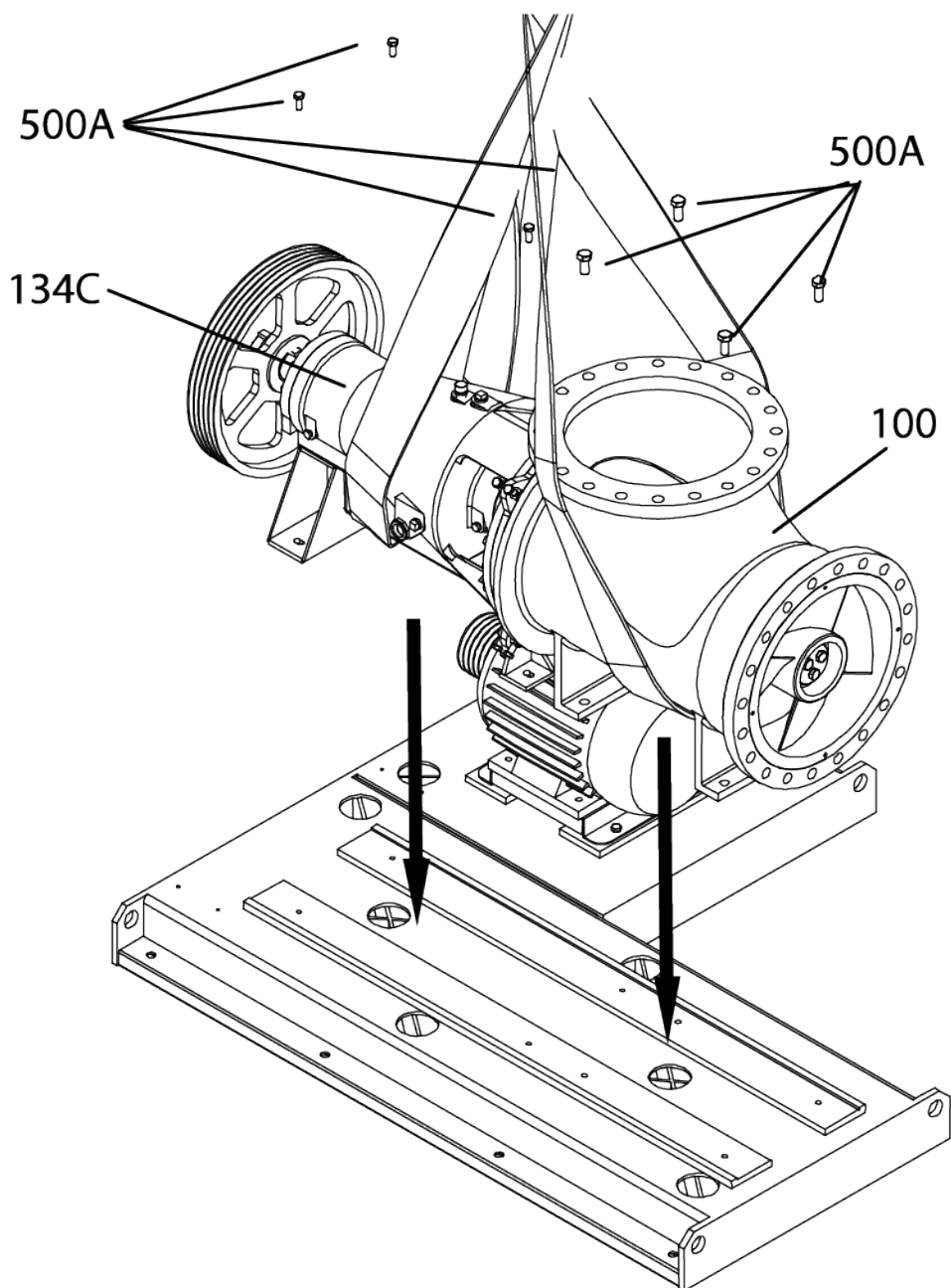
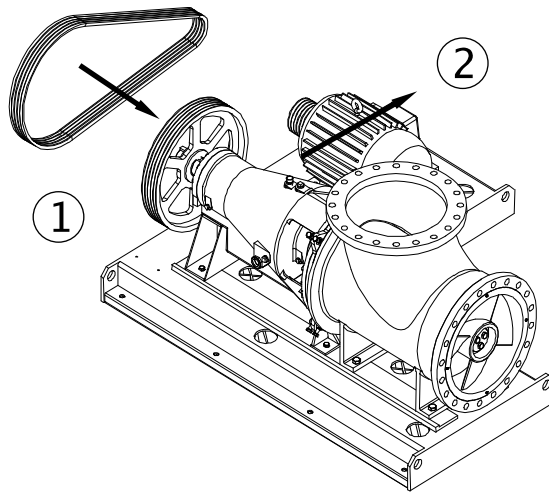

Figure 83: Pump to sub-base reassembly

4. Install V-belts and re-apply tension by adjusting the slide base away from the pump.
5. Adjust and check the tension per the drive manufacturers instructions.



1. Install belts
2. Shift slide base

Figure 84: V-belt installation

6. Fasten the guard base (501) to the sub-base using screws (502). Install the guard cover (500) using screws (502).

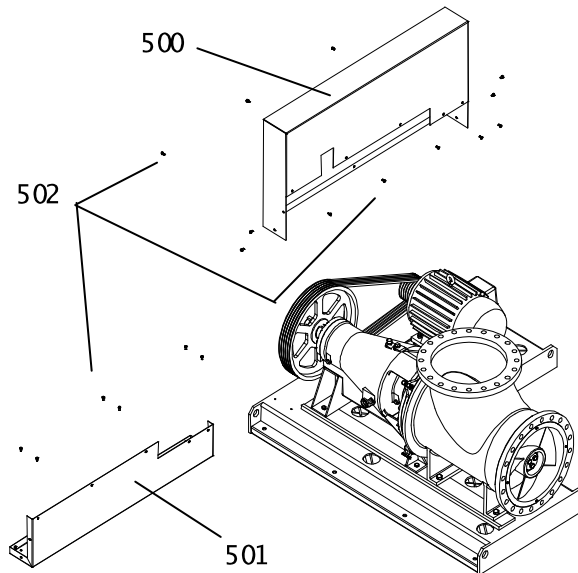

Figure 85: Guard base to sub-base reassembly

7. Check impeller alignment and re-align if necessary according to instructions for (impeller alignment).

Reassemble the drive / guard (direct connect configuration)

1. Using a crane, lift the pump into place on the sub-base.
Be careful not to damage the pump by striking any beams or walls that may be near the pump.
2. If any shims were found under the bearing housing feet during disassembly replace them at this time.
3. Install the pump to sub-base bolts (500A) and remove the lifting straps or chains from around the bearing housing (134C) and elbow (100).

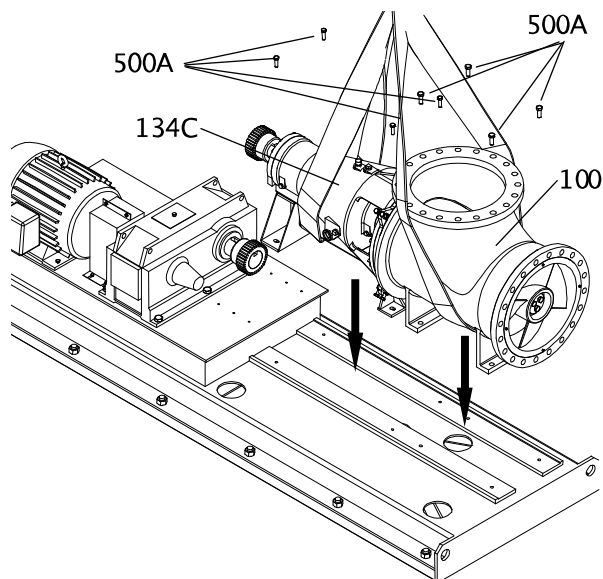

Figure 86: Direct drive - pump to sub-base reassembly

4. Align the gear box and pump coupling halves as described in sub-base installation section. If the motor and gear box were moved during disassembly re-align they must be re-aligned also.
5. Wrap the coupling cover around the coupling halves and install the fasteners that hold the coupling cover together.

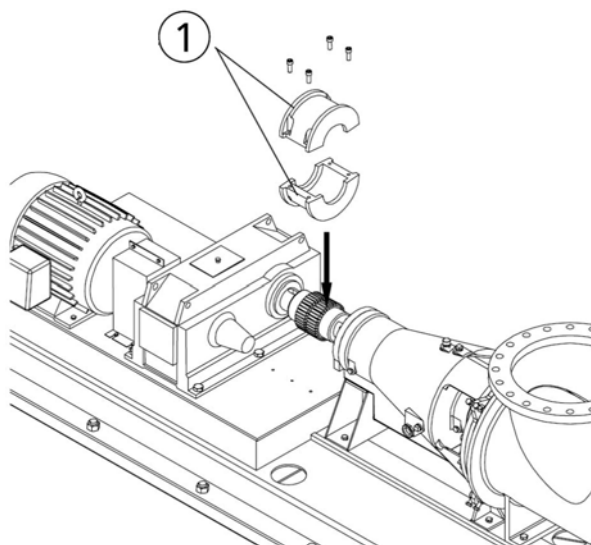

Figure 87: Coupling cover reassembly

6. Bolt the two halves of the coupling guard (500) together and install over the coupling.
7. Fasten the guard to the sub-base using screws (502).

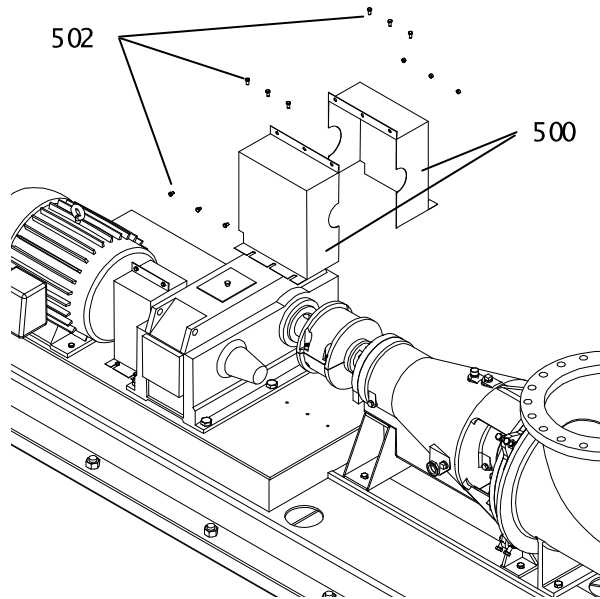

Figure 88: Coupling guard reassembly

8. Check impeller alignment and re-align if necessary according to instructions impeller alignment.
9. Fill pump with proper lubricant. Refer to preventative maintenance for requirements.
10. Connect all auxiliary piping and tubing
11. Fill system piping so pump impeller is submerged, flush the pump if necessary.
12. Open all valves controlling flow “to and from” the pump.
13. Un-lock driver power and jog the pump motor to be sure the pump rotates with no binding or rubs. If all is proper, continue with pump start-up.



WARNING:

With power unlocked be careful so as to prevent accidental start-up and physical injury.



WARNING:

Operator should be aware of pumpage and safety precautions to prevent physical injury.

Troubleshooting

Pump Troubleshooting

Table 10: Pump Troubleshooting

Symptom	Cause	Remedy
No liquid delivered or intermittent flow	Pump not primed or prime lost, liquid level does not completely fill elbow	Fill system piping completely so the impeller is submerged
	Suction inlet clogged	Remove obstructions from pump inlet
	Impeller clogged with foreign material	Back flush pump or manually clean impeller
	Suction and /or discharge valve closed or clogged	Open valves to remove shut-off condition
	Wrong direction of rotation	Change rotation to concur with direction indicated by the arrow on the bearing housing
	Suction piping incorrect	Replace or modify suction piping
	Insufficient NPSH available	Increase liquid level or lower pump
	Air leak in suction line	Test suction piping for leaks
	Speed (rpm) too low	New drive or gear box to obtain higher pump speed
	Excess air entrapped in liquid	Install vent in piping or eliminate air source
Pump not producing rated flow or head	Impeller partly clogged	Back flush pump or manually clean impeller
	Insufficient suction head	Fill system piping so the liquid level is above the pump impeller centerline
	Pump not primed or prime lost, pump does not completely fill elbow	Fill system piping completely so the impeller is submerged
	Suction and/or discharge valve closed or clogged	Open valves to remove partially blocked condition
	Suction piping incorrect	Replace or modify suction piping
	Excessive air entrapped in liquid	Install vent in piping or eliminate air source
	Speed (rpm) too low	New drive or gear box to obtain higher pump speed
	Incorrect rotation	Check motor wiring
	Incorrect impeller or impeller diameter	Check vane angles and/ or impeller clearances
	System head too high	Check system curve calculations, reduce system resistance
	Instruments give erroneous readings	Check and calibrate instruments, replace if necessary
	Worn or broken impeller, bent vanes	Inspect and replace if necessary
Pump assembled incorrectly	Compare pump assembly to instruction manual	

Symptom	Cause	Remedy
Wear of internal wetted parts is accelerated	Insufficient NPSH available	Increase liquid level or lower pump
	Chemicals in liquid other than specified	Analyze pumpage and correct or change pump wet end materials to suit pumpage composition
	Pump assembled incorrectly	Compare pump assembly to instruction manual
	Higher solids concentration than specified	Analyze pumpage and correct or change pump wet end materials to harder composition
Excessive leakage from stuffing box	Packing gland improperly adjusted	Tighten gland nuts
	Stuffing box improperly packed	Check packing and re-pack box
	Worn mechanical seal parts	Replace worn parts
	Overheating mechanical seal	Check lubrication and cooling lines
	Shaft sleeve scored	Re-machine or replace as required
Packing has short life	Pump run off design point	Check head and flow, AF's should normally be run between 75% and 125% of BEP
	Shaft/shaft sleeve worn	Replace shaft or shaft sleeve if necessary
	Packing gland not properly adjusted	Replace packing and readjust gland as specified in the operating manual
	Packing not properly installed	Check packing manufacturer's instructions
	Pump not assembled correctly	Compare pump assembly to instruction manual

Symptom	Cause	Remedy
Bearings run hot and or fail on a regular basis	Lubricant level	Be sure the oil level is at center line of sight glass
	Improper lubricant	Check lubricant for suitability
	Not lubricated enough	Increase frequency of grease lubrication
	Broken or bent impeller vanes	Check impeller dimensions and vane layout
	Excessive shaft misalignment	Check shaft run-out and consult factory
	Inadequate lubricant cooling	Check pumpage temperature and add oil cooling system if necessary
	Axial thrust or radial load higher than bearing rating	Calculate bearing life for make and model bearing
	Improper coupling lubrication	Check coupling lubrication schedule in manufacturers installation, operation, maintenance manual
	Coupling out of balance	Check pump and drive component vibration levels, rebalance coupling if necessary
	Suction pressure too high	Check liquid levels and static suction pressure
	Bearing incorrectly installed	Check bearing orientation to sectional drawing
	Impeller out of balance	Check pump vibrations, if necessary rebalance impeller
	Excessive shaft deflection	Check shaft diameter, sag and deflection, consult factory
	Pump run off design point	Check head and flow, AF's should normally be run between 75% and 125% of BEP
	Lubricant contamination	Inspect oil or grease for contaminants
	Piping not properly anchored	Check to see if excessive pipe strain is being transferred to pump flanges
	Pump and/or driver not secured to sub-base	Check fasteners, if loose check alignment and re-tighten
	Specific gravity higher than specified	Analyze pumpage and compare to specified gravity
Viscosity higher than specified	Analyze pumpage and compare to specified viscosity	
Pump assembled incorrectly	Compare pump assembly to instruction manual	
Partly clogged impeller causing Imbalance	Back flush pump or manually clean impeller	

Symptom	Cause	Remedy
Pump is noisy or vibrates at higher than normal levels	Broken or bent impeller or shaft	Replace as required
	Pump foundation not rigid or sub-base not completely secured	Tighten hold down bolts on sub-base Check foundation rigidity
	Impeller out of balance	Check impeller balance
	Motor not secure	Check motor fasteners
	Improper coupling lubrication	Check coupling lubrication schedule in manufacturers installation, operation, maintenance manual
	Bearing incorrectly installed	Check bearing orientation to sectional drawing
	Coupling out of balance	Check pump and drive component vibration levels, rebalance coupling if necessary
	Pump operating speed too close to system's natural frequency	Change speed to be +/- 20% of the pumps natural frequency
	Impeller partly clogged	Back flush pump or manually clean impeller
	Impeller clearances too tight	Check impeller clearances adjust if necessary
	Pump assembled incorrectly	Compare pump assembly to instruction manual
	Pump run off design point	Check head and flow, AF's should normally be run between 75% and 125% of BEP
	Excessive shaft deflection	Check shaft diameter, sag and deflection, consult factory
	Worn bearings	Replace
	Suction or discharge piping not anchored or properly supported	Anchor per Hydraulic Institute Standards Manual recommendation
	Suction and/or discharge valve closed or clogged	Open valves to remove partially blocked condition
	Excessive shaft misalignment	Check shaft run-out and consult factory
Pump assembled incorrectly	Compare pump assembly to instruction manual	
Pump is cavitating, insufficient NPSH available	System problem, increase liquid level or lower pump	

Symptom	Cause	Remedy
High rate of mechanical seal failure	Insufficient NPSH available	Increase liquid level or lower pump
	Excessive shaft misalignment	Check shaft run-out and consult factory
	Suction pressure too high	Check liquid levels and static suction pressure
	Bearing installed incorrectly	Check bearing orientation to sectional drawing
	Impeller out of balance	Check pump vibrations, if necessary rebalance impeller
	Overheating of seal faces	Check flush flow with mfg's recommendation, increase if necessary
	Excessive shaft deflection	Check shaft diameter, sag and deflection, consult factory
	Lack of seal flush to seal faces	Check shaft diameter, sag and deflection, consult factory
	Incorrect seal installation	Check seal materials vs. pumpage to determine compatibility
	Pump is run dry	Fill system piping completely so the impeller is submerged
	Pump run off design point	Check head and flow, AF's should normally be run between 75% and 125% of BEP
	Shaft/shaft sleeve worn	Replace shaft or shaft sleeve if necessary
	Coupling out of balance	Check pump and drive component vibration levels, rebalance coupling if necessary
	Sub-base not installed correctly	Compare pump sub-base installation to instruction manual
	Bearing failing	Replace if necessary
	Piping not properly anchored	Check to see if excessive pipe strain is being transferred to pump flanges
	Pump and/or driver not secured to sub-base	Check fasteners, if loose check alignment and re-tighten
	Specific gravity higher than specified	Analyze pumpage and compare to specified gravity
	Viscosity higher than specified	Analyze pumpage and compare to specified viscosity
Pump assembled incorrectly	Compare pump assembly to instruction manual	
Motor requires excessive power	Head higher than rating. Reduced flow	Check for fouling in the piping or obstruction in discharge
	Liquid heavier than expected	Check specific gravity and viscosity
	Incorrect rotation	Jog motor and check rotation
	Pump run off design point	Check measured head and flow to specified head and flow
	Stuffing box packing too tight	Readjust packing. Replace if worn
	Rotating parts binding, internal clearances too tight	Check internal wearing parts for proper clearances

Parts Listings and Cross-Sectionals

Cross sectional drawing (shown with optional restrictor bushing adapter)

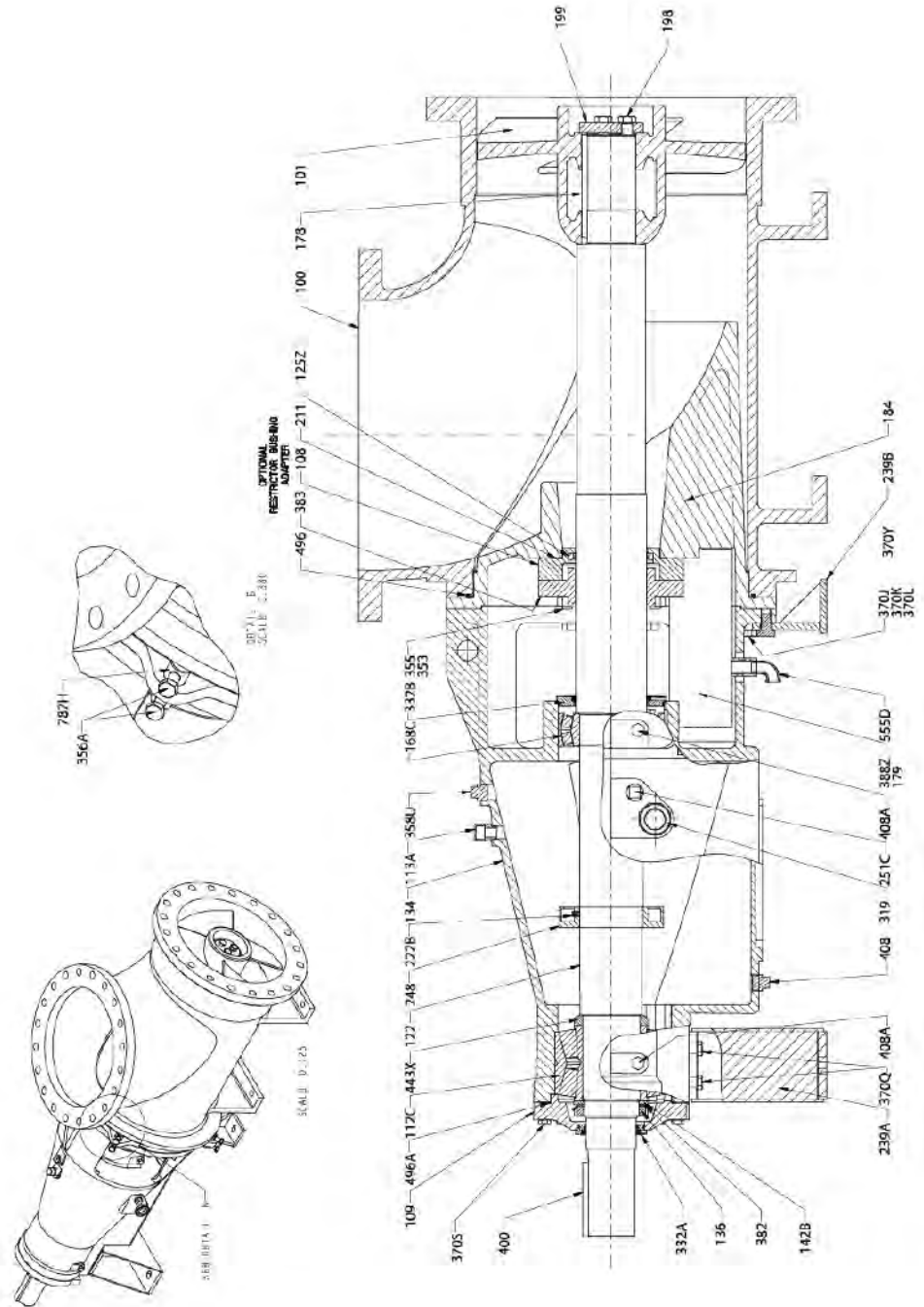

Figure 89: Cross sectional (shown with optional restrictor bushing)

Parts list and materials of construction

Table 11: Parts list and materials of construction

Item	Part Name	Standard Materials of Construction (Alloy)									
		Cast iron	304	316	Alloy 20	Duplex SS	904L	Monel	Inconel	Nickel	Titanium
100	Casing	Alloy									
101	Impeller										
105	Lantern ring	Teflon									
106	Packing	Process dependent									
107	Gland	Alloy									
112C	Outboard bearing	Steel									
113A	Oil breather										
119C	Thrust bearing retainer	Cast iron									
122	Shaft	Alloy									
126	Shaft sleeve										
134C	Bearing housing	Cast iron									
136	Bearing locknut	Steel									
142B	Keyed washer										
168C	Inboard bearing										
178	Impeller key	Alloy									
178D	Sleeve key										
179	Drip pan	316 standard, (packed pump only)									
184	Stuffing box cover	Alloy									
198	Impeller screw										
199	Impeller lockplate										
220	Stuffing box	Steel									
222N	Set screw, oil wheel										
239A	Frame foot, outboard										
239B	Frame foot, inboard	Iron									
248	Oil wheel										
251C	Plug, oiler	Steel									
315A	Elbow w/casing	Alloy									
315B	Liner, elbow										
332	Laby seal, outboard	Bronze									
333	Laby seal, inboard										
351A	Gasket, elbow casing	Process dependent									
351W	Gasket, stuffing box										
353	Gland stud	Nickel plated steel									
355	Gland nuts										
356A	Ajusting bolts	Steel									
360W	Cover, oil cooling										
361	Gasket, oil cooling	BUNA-N									
370C	HHCS bearing housing / elbow	Steel									
370F	HHCS, oil cooling										
370L	HHCS SB cover-bearing housing	Alloy									
370M	HHCS impeller										
370Q	Frame foot, rear	Steel									
370Y	Frame foot screws										
382	Lock washer	Application dependent									
383	Mechanical seal										
400	Coupling key	Steel									
408	Plug, drain										
408A	Sensor plugs										
408D	Oil fill plug										
408H	Plug, impeller	Alloy									
412D	O-ring, sleeve	Process dependent									
412T	O-ring, impeller cap	Process dependent									
412Y	O-ring, end cover	BUNA-N									

Parts Listings and Cross-Sectionals

Item	Part Name	Standard Materials of Construction (Alloy)									
		Cast iron	304	316	Alloy 20	Duplex SS	904L	Monel	Inconel	Nickel	Titanium
443X	Spacer	Steel									
469D	Set screw, sleeve	Alloy									
496	O-ring, stuffing box cover	Process dependent									
496C	O-ring, impeller nose										
540C	Gasket, bearing housing	BUNA-N									
600Z	HHCS, SBX/SBXCVR	Steel									
787H	Adjusting bar	Steel									
788Z	End cover screws										
799C	HHCS casing										
799D	Nuts, casing	Steel									
799E	HHCS SB cover-frame	Steel									
799F	HHCS foot, front	Stainless steel standard, other options available									
799G	Drip pan elbow										
799H	Drip pan screws	Stainless steel									
799J	Adjusting lug, casing	Steel									
799K	HHCS adj. screw										
799L	HHCS adj. lug										
998E	Impeller cover	Alloy									
9727	Male connector	Steel									
9728	Female connector										
9841	Cooling coil	Stainless steel									

Cross sectional, AF with packing, non back-pullout

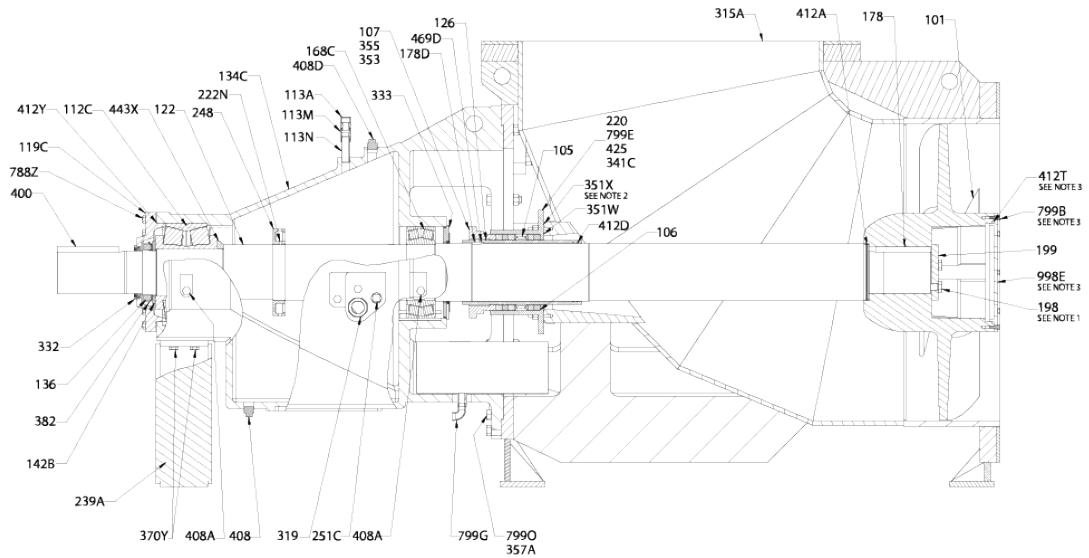

Figure 90: 20", 24", 700MM, 30" AF w/packing, non back-pullout

Cross sectional, AF with mechanical seal, non back-pullout

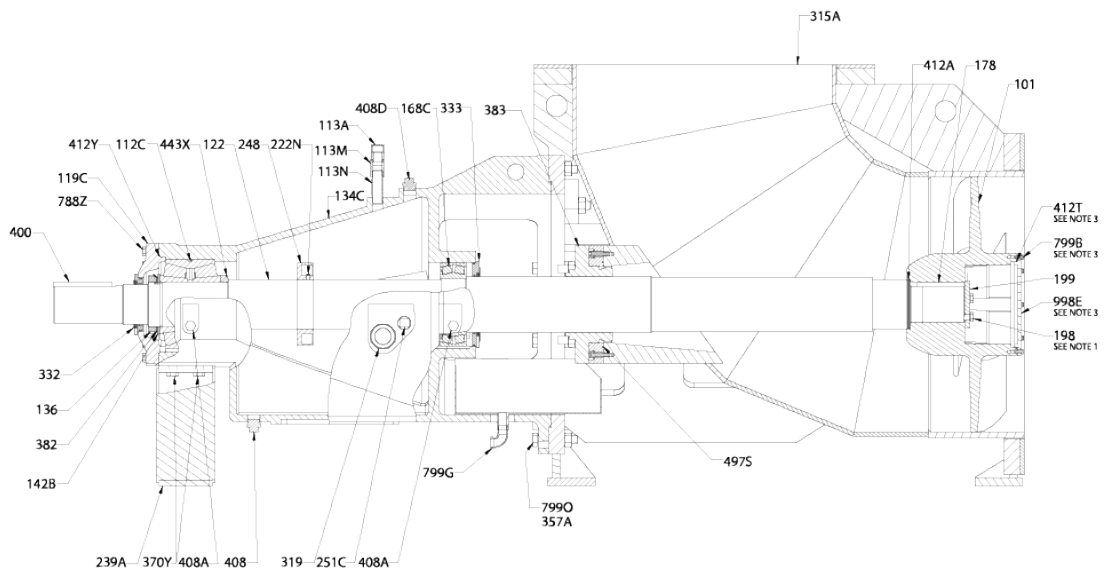

Figure 91: 20", 24", 700MM, 30", 36# AF w/mechanical seal, non back-pullout

Parts list and materials of construction for fabricated elbows

Table 12: Parts list and materials of construction

Item	Part Name	Standard Materials of Construction (Alloy)					
		Nickel	Carbon Steel	316LSS	Duple x 2205 (CD4)	904L	Monel
101	Impeller	Alloy					
105	Lantern ring	Teflon					
106	Packing	Process dependent					
107	Gland	Alloy					
108D	Mechanical seal adapter						
112C	Out-board bearing	Steel					
113A	Oil breather						
113M	Coupling						
113N	Pipe Nipple						
119C	Thrust bearing retainer						
122	Shaft	Alloy					
126	Shaft sleeve	Cast iron					
134C	Bearing housing						
136	Bearing locknut	Steel					
142B	Keyed washer						
168C	Inboard bearing						
178	Impeller key	Alloy					
178D	Sleeve key	316 standard, other options available					
179	Drip pan						
198	Impeller screw	Alloy					
199	Impeller lockplate						
220	Packing chamber						
222N	Set screw, oil wheel	Steel					
239A	Frame foot						
248	Oil wheel	Iron					
251C	Plug, oiler	Steel					
315A	Fabricated elbow	Alloy/Steel					
319	Sight window	Steel					
332	Laby seal, outboard	Bronze					
333	Laby seal, inboard						
341C	Bolt, hex tap (radial adjustment)	Stainless steel					
351W	O-ring, packing chamber	Process dependent					
351X	O-ring, packing chamber						
353	Gland studs	Nickel plated steel					
355	Gland nuts						
356A	Adjusting bolts	Steel					
356E	HHCS, frame to elbow (lug)						
357A	Hex nut, frame to elbow						
370	Screw, socket head - mechanical seal adapter	Stainless steel					
370Y	HHCS, frame foot	Steel					
382	Lockwasher	Application dependent					
383	Mechanical seal						
400	Coupling key	Steel					
408	Plug, drain						
408A	Sensor plugs						
408D	Oil fill plug						
412A	O-ring, shaft / impeller						
412D	O-ring, sleeve	Process dependent					
412T	O-ring, impeller cap						
412Y	O-ring, end cover	Buna-N					
415	Adjusting lug	Steel					

Item	Part Name	Standard Materials of Construction (Alloy)					
		Nickel	Carbon Steel	316LSS	Duple x 2205 (CD4)	904L	Monel
425	Hex nut, packing chamber	Stainless steel					
443X	Spacer	Steel					
469D	Set screw, sleeve	Alloy					
497S	O-ring, mechanical seal adapter	Process dependent					
536W	Washer, mechanical seal adapter	Stainless steel					
788Z	End cover screws	Steel					
799B	Screw, impeller cap	Alloy					
799E	Stud - packing chamber	Stainless steel					
799G	Drip pan elbow	Stainless Steel Standard, other options available					
799H	Drip pan screws						
799I	Drip pan washer						
799O	HHCS, Frame to elbow (lower)	Steel					
998E	Impeller cover	Alloy					

MXR bearing configurations

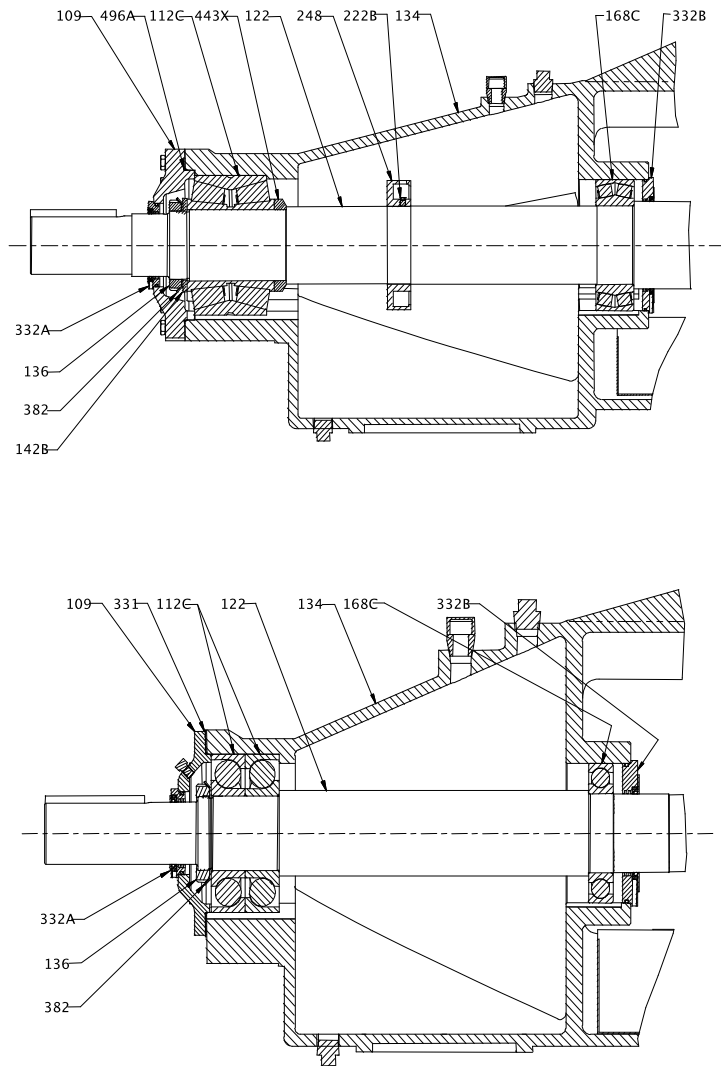

Figure 92: MXR bearing configurations

AF with separate casing

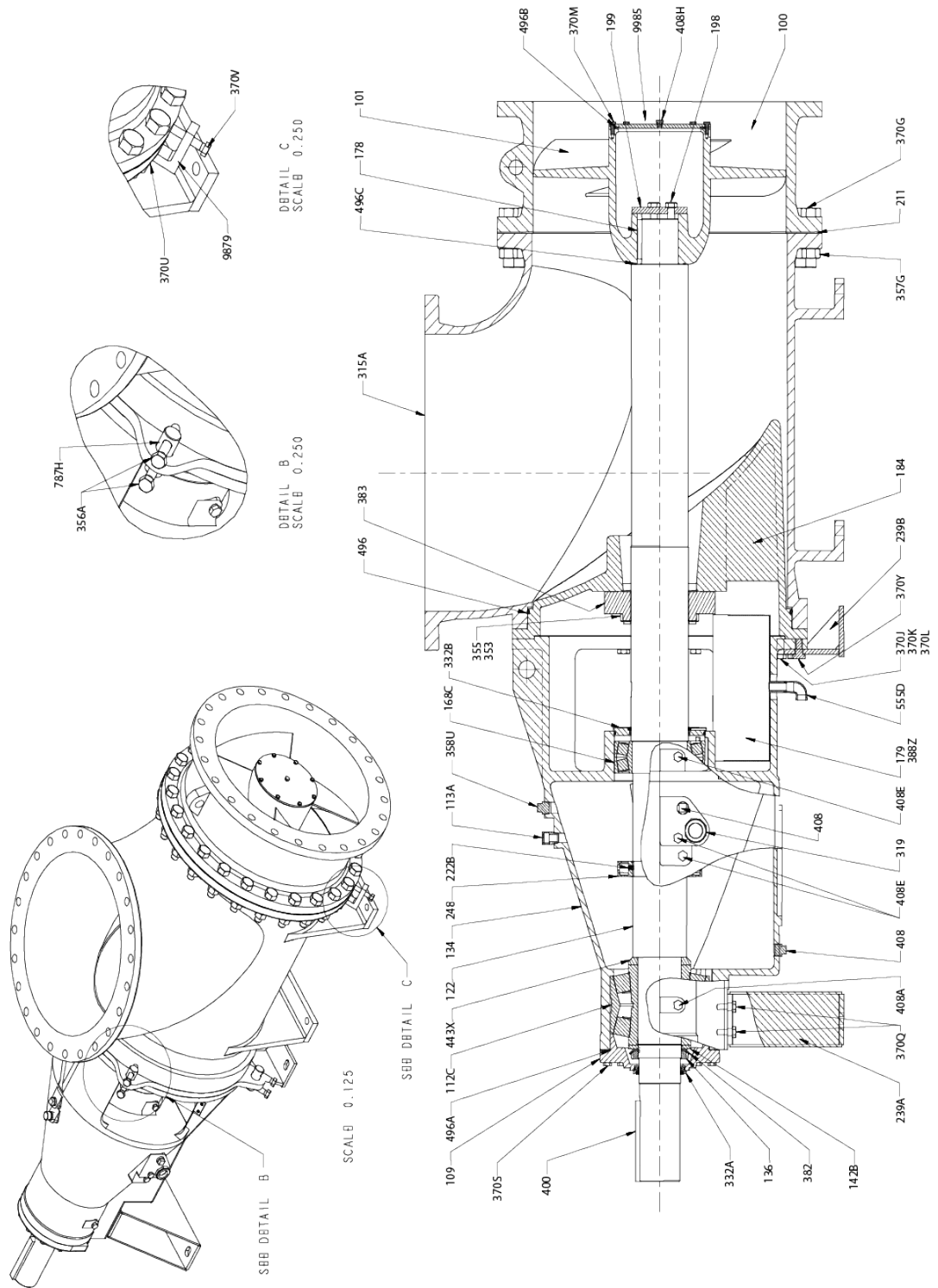

Figure 93: AF with separate casing

AF options

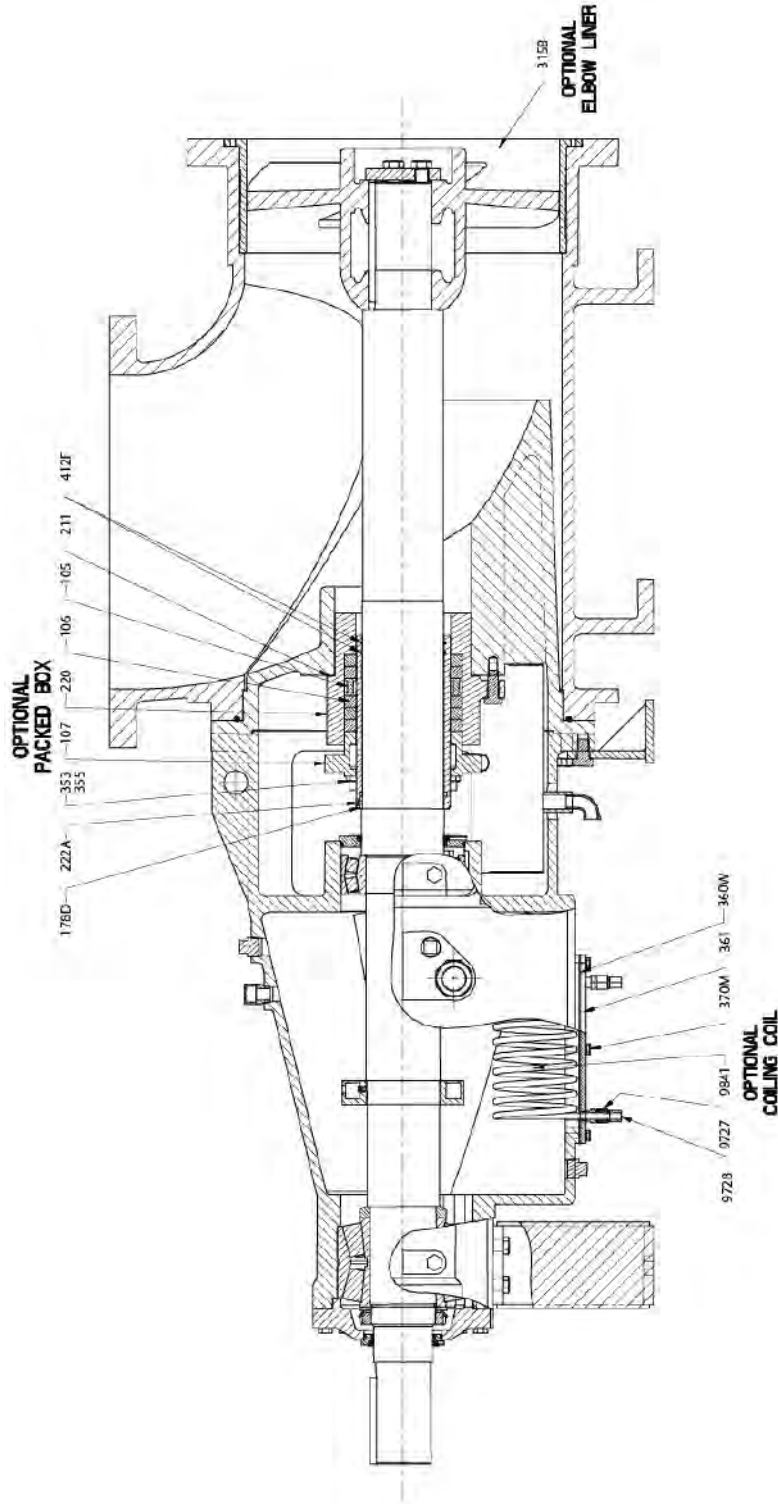

Figure 94: AF options

Appendix

Bearing alignment

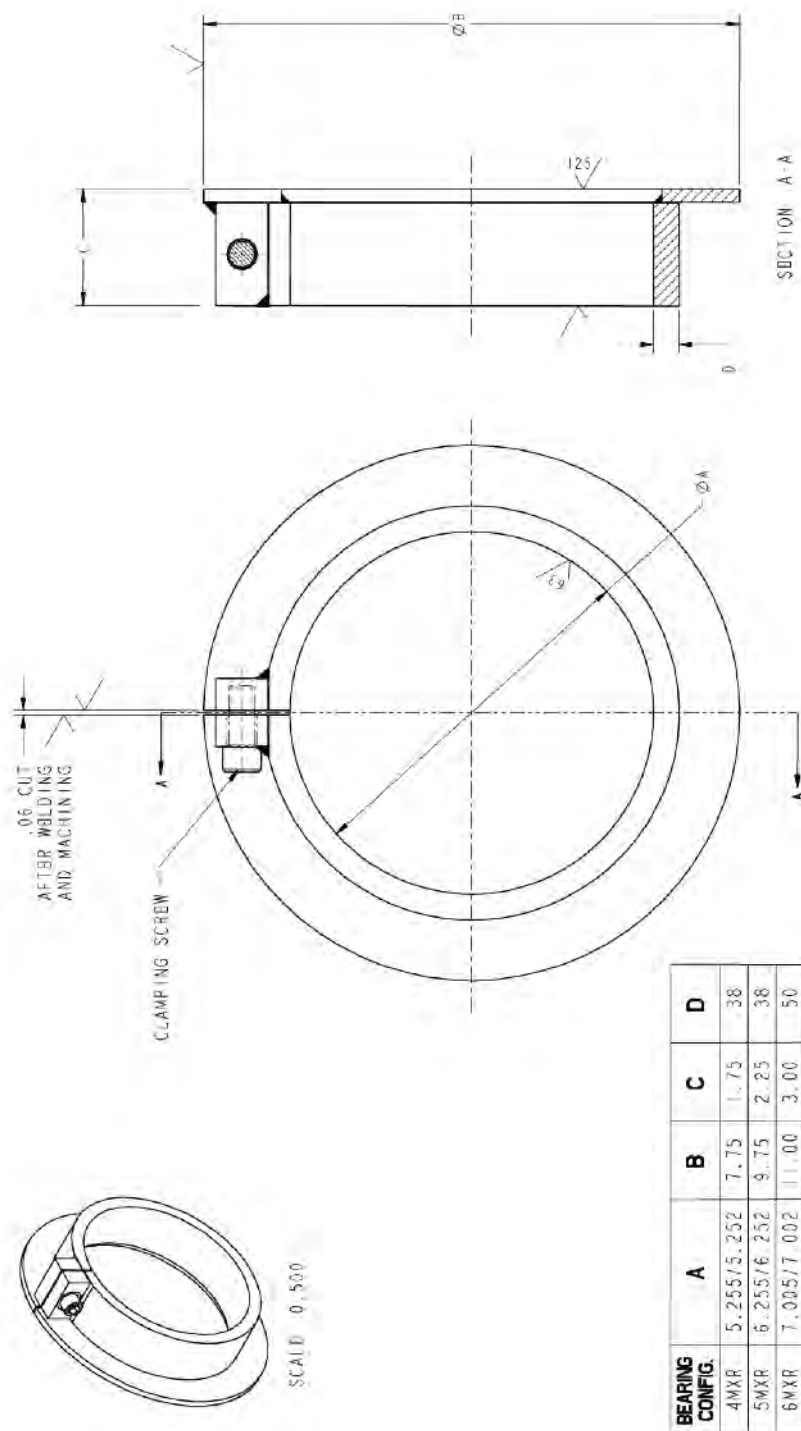

Figure 95: Bearing alignment collar detail

Maximum bolt torque values N-M | Ft-Lb

Table 13: Maximum bolt torque table

Sizes	Cold Drawn Steel ASTM A108 Grade 1213		316 Stainless Steel ASTM A276 Type 316		Cold Drawn Alloy Steel ASTM A193 Grade B7	
	Lubricated	Dry	Lubricated	Dry	Lubricated	Dry
5/16-18	6 4	9 6	9 6	13 9	14 10	23 17
3/8-16	9 6	13 9	15 11	23 17	25 18	37 27
1/2-13	21 15	31 23	37 27	55 41	40 29	59 44
5/8-11	41 30	62 45	74 54	110 81	60 44	90 66
3/4-10	72 53	108 80	90 66	135 99	118 87	129 95
7/8-9	116 85	174 128	144 106	216 159	209 154	177 131
1-8	174 128	261 192	216 159	324 239	504 371	755 557
1 1/2-6	600 443	1200 885	500 369	745 550	1859 1371	2789 2057

Appendix II

Installation and Removal of the 30 inch and 36 inch Impeller Using the Goulds Impeller Assembly Tool

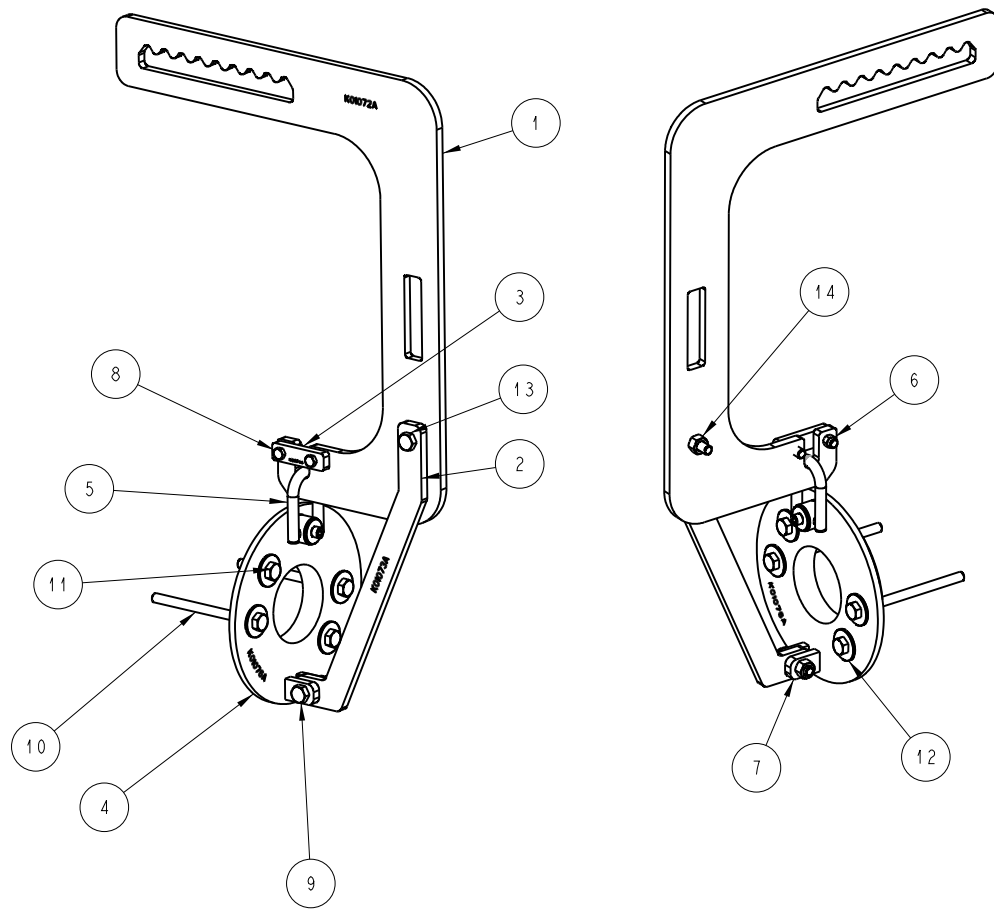

Figure 96: Impeller assembly tool

Use of the Goulds Impeller Assembly Tool on the 30 and 36 inch Impeller

1. Ensure the impeller cover and shaft washer is removed.
2. Fasten the assembly tool impeller plate (4) to the impeller with the impeller plate locking screws (10 or 11).
3. Rotate the shaft so the swivel hoist ring (5) is at the 12 o'clock position.
4. Using a crane, move the assembly tool bracket (1) so the swivel hoist ring (5) is located in the bracket groove.
5. Attach the plate (3) to the bracket (1) with the supplied screws (8) and nuts (6).
6. Attach the assembly tool frame (2) to the impeller plate (4) with the supplied screws (9) and nuts (7).
7. Attach the assembly tool frame (2) to the assembly tool bracket (1) with the supplied screws (13) and nuts (14).

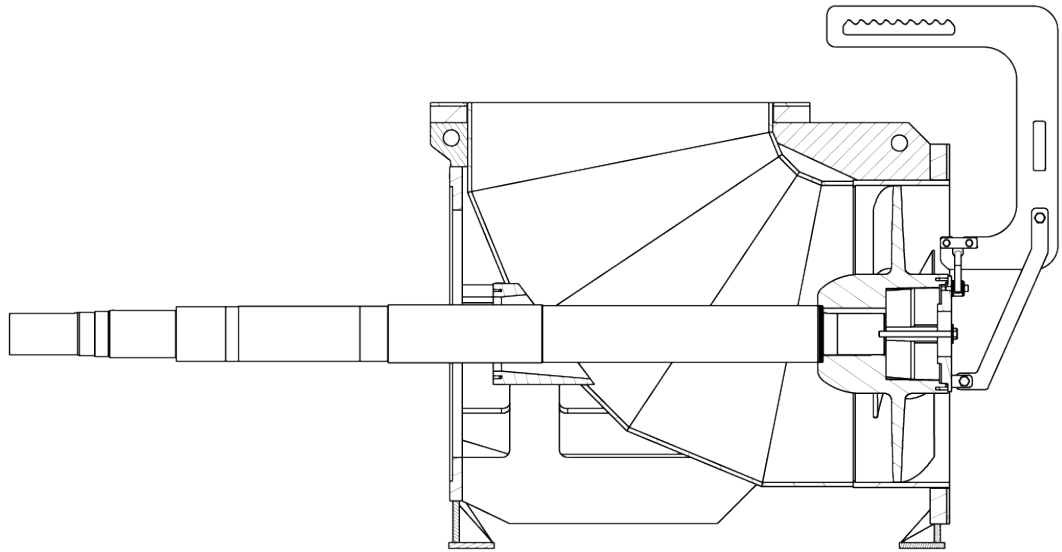

Figure 97: Assembly tool attached to the propeller in the elbow

Visit our website for the latest version of this document and more information:

<http://www.gouldspumps.com>



ENGINEERED FOR LIFE

Goulds Pumps Inc.
240 Fall Street
Seneca Falls, NY 13148
USA
Tel. 1-800-446-8537
Fax 1-315-568-2418