

Installation manual IM/UP-EN Rev. B

# Universal pneumatic rotary actuator Types UP1/2/3/4/5/6/7

Measurement made easy



# Contents

<b>1 Introduction .....</b>	<b>3</b>	<b>3 Installation.....</b>	<b>13</b>
1.1 Overview.....	3	3.1 Introduction.....	13
1.2 Partial machine .....	3	3.2 Unpacking and Inspection.....	13
<b>2 Safety .....</b>	<b>4</b>	3.3 Location considerations .....	13
2.1 General information and notes for the reader .....	4	3.4 Enclosure removal.....	13
2.2 Intended use.....	4	3.4.1 Type UP1 actuator.....	13
2.3 Target groups and qualifications .....	4	3.4.2 Type UP2 actuator.....	13
2.4 Warranty provisions .....	4	3.4.3 Types UP3 and UP4 Actuator.....	16
2.5 Plates and symbols.....	5	3.4.4 Types UP5, UP6 and UP7 Actuator .....	16
2.5.1 Safety / Warning symbols, note symbols .....	5	3.5 Wiring connections, tubing connections and cabling ...	19
2.5.2 Name plate.....	5	3.5.1 Connecting tubing .....	19
2.6 Transport safety information.....	6	3.5.2 Connecting wiring.....	19
2.7 Storage conditions.....	6	3.5.3 Grounding .....	19
2.8 Installation safety information .....	6	3.5.4 Air quality.....	19
2.9 Safety information		3.5.5 Characterizable pneumatic positioner tubing....	20
for pneumatic / electrical installation.....	6	3.5.6 Characterizable I/P positioner	
2.10 Operating safety information .....	7	tubing and wiring .....	20
2.11 Maintenance safety Information.....	7	3.5.7 Solenoid tubing and wiring.....	21
2.12 Safety information related to		3.5.8 Master / Slave tubing connections	
the raw materials and supplies.....	7	for Type UP6 actuators .....	22
2.13 Returning devices .....	7	3.6 Installation of optional equipment .....	25
2.14 Integrated management system.....	7	3.6.1 Reserve air tank tubing and wiring .....	25
2.15 Disposal.....	8	3.6.2 Air failure lock tubing.....	32
2.15.1 Information on WEEE Directive 2002/96/EC		3.6.3 Pneumatic shaft position transmitter tubing	
(Waste Electrical and Electronic Equipment) .....	8	for Types UP2 to UP7 actuators .....	40
2.15.2 RoHS Directive 2002/95/EC .....	8	3.6.4 Volume booster tubing	
2.16 Listing of possible hazards.....	8	for Type UP6 and UP7 actuators .....	40
		3.6.5 Alarm /Travel switch contact wiring	
		for Types UP1 to UP7 Actuators .....	41
		3.6.6 Shaft position transmitter wiring for	
		Types UP1 and UP2 Actuators .....	41
		3.6.7 Strip heater wiring	
		for Types UP2 to UP7 actuators .....	42
		3.7 Pre-operating adjustments .....	43
		3.7.1 Control loading arrangements.....	43
		3.7.2 Operating lever adjustment .....	43
		3.7.3 Position indicator .....	44
		3.7.4 Mechanical stop adjustment	
		for Types UP1 and UP2 actuators.....	44
		<b>Appendix A – Documents .....</b>	<b>45</b>
		A.1 Other applicable documents – see Note 1.....	45
		A.2 Approval and certificates.....	45
		<b>Appendix B – EC declarations.....</b>	<b>46</b>
		<b>Appendix C – Dimension drawings .....</b>	<b>47</b>
		<b>Appendix D – Air cylinder replacement.....</b>	<b>55</b>
		D.1 Rotary vane and air cylinder repair and replacement ...	55
		<b>Appendix E – Additional pneumatic</b>	
		<b>arrangement drawings.....</b>	<b>56</b>
		<b>Notes .....</b>	<b>63</b>

# 1 Introduction

## 1.1 Overview

This installation manual provides users with the safety aspects for Type UP universal pneumatic rotary actuators. It is important for safety and operating reasons to read and understand this manual. Do not install or complete any tasks or procedures related to operation, calibration, maintenance or repair until doing so.

## 1.2 Partial machine

UP actuators are partly completed machines with respect to the EU machine safety directive, 2006/42/EC. System designers and machine installers are responsible for incorporating UP actuators into a complete drive system and it's compliance with the EU machine directive as well other EU directives.

UP actuators are complex components in a complete functional and safe machine. Among the tasks performed by system designers and installers are mechanical linkage design, safeguarding for the moving linkages, drive linkage motion lockout and lock in-place and proper pneumatic / electrical connections throughout the completed machine. There are two opposing forces encountered in every integrated machine that incorporates a UP actuator. The UP rotational force, produced from pressurized air inside the UP, is opposed by the process load via the UP drive arm and the interconnecting mechanical linkages. Even when the actuator is stationary, these large forces are present and acting in opposition. UP actuators are operated using automatic control according to process conditions and circumstances; as a precautionary measure it is reasonable and safe to expect that the drive arm can move at any time.

## 2 Safety

### 2.1 General information and notes for the reader

Read these instructions carefully prior to installing and commissioning the device.

These instructions are an important part of the product and must be kept for future reference.

These instructions are intended as an overview and do not contain detailed information on all designs for this product or every possible aspect of installation, operation and maintenance.

For additional information or if specific problems occur that are not discussed in these instructions, refer to the UP actuator operating instructions.

The content of these instructions is neither part of any previous or existing agreement, promise or legal relationship nor is it intended to change the same.

This product is built based on state-of-the-art technology and is operationally safe. It has been tested and left the factory in perfect working order from a safety perspective. The information in the manual must be observed and followed in order to maintain this state throughout the period of operation.

Modifications and repairs to the product may be performed only if expressly permitted by these instructions. Only by observing all of the safety instructions and all safety / warning symbols in these instructions can optimum protection of both personnel and the environment, as well as safe and fault-free operation of the device, be ensured. Information and symbols directly on the product must be observed. They may not be removed and must be fully legible at all times.

### 2.2 Intended use

The actuators are used exclusively for operating final control elements (for example valves and vanes). Using these actuators for any other purpose introduces the risk of personal injury and can also damage or impair the device's operational reliability.

### 2.3 Target groups and qualifications

Installation, commissioning and maintenance of the product may be performed only by trained specialist personnel who have been authorized by the plant operator accordingly. The specialist personnel must read and understand these safety instructions. The operating company must strictly observe the applicable national regulations relating to the installation, function testing, repair and maintenance of pneumatic / electrical products.

### 2.4 Warranty provisions

Using the device in a manner that does not fall within the scope of its intended use, disregarding these instructions in this manual, using non-qualified personnel or making unauthorized alterations releases the manufacturer from liability for any resulting damage. This renders the manufacturer's warranty null and void.

## 2.5 Plates and symbols

### 2.5.1 Safety / Warning symbols, note symbols



#### **DANGER – Serious damage to health / risk to life**

This symbol in conjunction with the signal word "DANGER" indicates an imminent danger. Failure to observe this safety information will result in death or severe injury.



#### **DANGER – Serious damage to health / risk to life**

This symbol in conjunction with the signal word "DANGER" indicates an imminent electrical hazard. Failure to observe this safety information will result in death or severe injury.



#### **WARNING – Bodily injury**

This symbol in conjunction with the signal word 'WARNING' indicates a potentially dangerous situation. Failure to observe this safety information may result in death or severe injury.



#### **WARNING – Bodily injury**

This symbol in conjunction with the signal word "WARNING" indicates a potential electrical hazard. Failure to observe this safety information may result in death or severe injury.



#### **CAUTION – Minor injuries**

This symbol in conjunction with the signal word "CAUTION" indicates a potentially dangerous situation. Failure to observe this safety information may result in minor or moderate injury. The symbol may also be used for property damage warnings.



#### **NOTICE – Property damage**

This symbol indicates a potentially damaging situation. Failure to observe this safety information may result in damage to or destruction of the product and / or other system components.



#### **IMPORTANT (NOTE)**

This symbol indicates operator tips, particularly useful information or important information about the product or its further uses. The signal word "IMPORTANT (NOTE)" does not indicate a dangerous or harmful situation.

### 2.5.2 Name plate



#### **IMPORTANT (NOTE)**

The name plates shown here are only examples. The name plates attached to the device may be different to what you see here.

The name plate provides basic information in regards to the actuator and provides a means for identification.

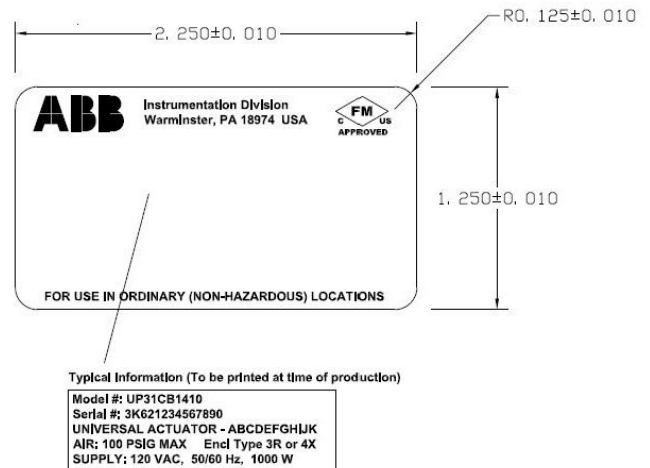

Fig. 2.1: UP Actuator name plate

## 2.6 Transport safety information

---



### **DANGER – Serious damage to health / risk to life**

Risk of death or serious injury due to the device falling down or toppling over.

---

Observe the following instructions:

- Do not stand under suspended loads.
- Do not detach the hoisting equipment until installation is complete.
- Use only the dedicated load pick-up points for moving the actuator.

Check the devices for possible damage that may have occurred during transport. Damages in transit must be recorded on the transport documents. All claims for damages must be claimed without delay against the carrier and before the installation. Ensure that the specified environmental conditions in the UP actuator product data sheet are complied with.

## 2.7 Storage conditions

---



### **IMPORTANT (NOTE)**

The storage data provided below assumes that the devices are fully closed and thus comply with the degree of protection stated in the technical specifications. When devices are supplied, their degree of protection is guaranteed. If they have been subsequently tested or commissioned, the degree of protection must be ensured again before they are put into storage.

---

- Avoid direct exposure to the elements (for example, rain or snow).
- Observe the permissible storage and transport temperatures.
- Protect uncovered metallic surfaces with an appropriate long-term corrosion inhibitor.
- Observe the relevant long-term storage temperatures.

## 2.8 Installation safety information

---



### **DANGER – Serious damage to health / risk to life**

Risk of death or serious injury due to the device falling down or toppling over!

---

Observe the following instructions:

- Do not stand under suspended loads.
- Do not detach the hoisting equipment until installation is complete.
- Use only the dedicated load pick-up points for moving the actuator.
- Only qualified specialists who have been trained for these tasks are authorized to mount / adjust the actuator and make the pneumatic / electrical connection.
- When working on the actuator, always observe the locally-valid accident prevention regulations and the regulations concerning the installation of partial machine equipment.
- Make sure that no process forces are exerted on the control element.
- The load pick-up points on the actuator must be loaded only in a vertical direction. Use only the load pick-up points for lifting / lowering the actuator (without final control element mounted).

## 2.9 Safety information for pneumatic / electrical installation

---



### **DANGER – Serious damage to health / risk to life**

Possible electrical hazards.

---

- The pneumatic / electrical connection may be made only by authorized personnel and in accordance with the pneumatic / electrical circuit diagrams.
- Safe isolation of electrical circuits that are dangerous if touched is guaranteed only if the connected devices satisfy the requirements of DIN EN 61140 (VDE 0140 Part 1) – basic requirements for safe isolation.
- To ensure safe isolation, install pneumatic lines with separate shut-off valves and install electrical lines so that they are separate from electrical circuits that are dangerous if touched or implement additional isolation measures.

## 2.10 Operating safety information

---



### **DANGER – Serious damage to health / risk to life**

Risk of crushing or entanglement of body parts.

---

- Risk of injuries due to crushing between the lever and the actuator body or between the lever and the coupling rod.
- Do not reach into the danger zone or anywhere near where parts may move.
- Exclusively start the actuator with the lever cover installed (Types UP1 and UP2 only).

Before commissioning, ensure the environmental conditions specified in the UP Actuator product Data sheet are complied with.

If there is a chance that safe operation is no longer possible, take the device out of operation and secure it against unintended start-up.

When the actuator is installed in areas that may be accessed by unauthorized persons, the operator must put appropriate protective measures in place.

## 2.11 Maintenance safety Information

---



### **WARNING – Bodily injury**

Note that the actuator position may be changed accidentally by the repelling power of the final control element. Make sure that process forces are not exerted on the lever.

---

- Switch off the air supply and electrical power when working on the actuator or related subassemblies and take precautions to prevent unintentional switch-on.

## 2.12 Safety information related to the raw materials and supplies

---



### **CAUTION – Minor injuries**

Lubricants can contain additives that, under special conditions, may lead to adverse effects.

---

- Skin contact with lubricants may cause skin damage (skin irritations, inflammations, allergies). Avoid long-term, excessive or repeated skin contact. If lubricants contact skin, wash immediately with water and soap. Do not allow lubricants to get in contact with open wounds.
- If lubricant splashes into the eye, rinse with plenty of water for at least 15 minutes and then consult a doctor.
- When handling lubricants use appropriate skin protection and care products or wear oil-resistant gloves.

## 2.13 Returning devices

Use the original packaging or suitably-secure shipping containers if you need to return the device for repair purposes.

According to EC guidelines for hazardous materials, the owner of hazardous waste is responsible for its disposal or must observe the applicable regulations for shipping purposes.

All devices delivered to ABB must be free from any hazardous materials (for example acids, alkalis and solvents).

Contact your local ABB sales office for nearest service location.

## 2.14 Integrated management system

ABB Automation Products GmbH operates an integrated management system, consisting of:

- Quality management system to ISO 9001:2008
- Occupational health and safety management system to BS OHSAS 18001:2007 and
- Data and information protection management system

Environmental awareness is an important part of our company policy.

Our products and solutions are intended to have minimum impact on the environment and on people during manufacturing, storage, transport, use and disposal.

This includes the environmentally-friendly use of natural resources. We conduct an open dialog with the public through our publications.

## 2.15 Disposal

This product is manufactured from materials that can be recycled by specialist recycling companies.

### 2.15.1 Information on WEEE Directive 2002/96/EC (Waste Electrical and Electronic Equipment)

This product is not subject to WEEE Directive 2002/96/EC or relevant national laws (for example, ElektroG in Germany).

The product must be disposed of at a specialist recycling facility. Do not use municipal garbage collection points. According to the WEEE Directive 2002/96/EC, only products used in private applications may be disposed of at municipal garbage collection points. Proper disposal prevents negative effects on people and the environment and supports the reuse of valuable raw materials.

If it is not possible to dispose of old equipment properly, ABB Service can accept and dispose of returns for a fee.

### 2.15.2 RoHS Directive 2002/95/EC

With the Electrical and Electronic Equipment Act (ElektroG) in Germany, the European Directives 2002/96/EC (WEEE) and 2002/95/EC (RoHS) are translated into national law. ElektroG defines the products that are subject to regulated collection and disposal or reuse in the event of disposal or at the end of their service life. ElektroG also prohibits the marketing of electrical and electronic equipment that contains certain amounts of lead, cadmium, mercury, hexavalent chromium, polybrominated biphenyls (PBB) and polybrominated diphenyl ethers (PBDE) (also known as hazardous substances with restricted uses).

The products provided by ABB Automation Products GmbH do not fall within the current scope of regulations on hazardous substances with restricted uses or the directive on waste electrical and electronic equipment according to ElektroG. If the necessary components are available on the market at the right time, in the future these substances will no longer be used in new product development.

## 2.16 Listing of possible hazards



### **DANGER – Serious damage to health / risk to life**

Failure to operate the actuator in a safe manner can result in injury or death.

---

#### MOVING UP ACTUATOR INTO PLACE (Transport)

- The UP actuator is heavy and can tip over or cause crushing injuries whenever it is moved.

#### INSUFFICIENT FLOOR ANCHORING (Installation)

- There are two opposing forces encountered in every integrated machine that incorporates a UP actuator. The UP rotational force is opposed by the process load via the UP drive arm and the interconnecting linkages. Even when the actuator is stationary these large forces are present and acting in opposition. Drive linkage motion lockout and lock in-place is required before starting any UP maintenance activity. External to the UP actuator (that is a partial machine) a set of mechanical linkages are engineered, installed and commissioned by the machine designer and installers. The UP actuator must be adequately fastened down and anchored rigidly to the floor. The floor and the fasteners must be of sufficient strength to handle the expected forces. The UP actuator enclosure and floor mounting must be rigid and motionless.

#### I-PORT / S-PORT CONNECTIONS (Installation)

- UP actuators that use Type AV1 positioners use a 3 to 15 psi pneumatic setpoint control signal (I-Port). During UP installation it is important to not confuse the S-Port and I-Port connections. Machine designers and installers are reminded that UP actuators contain pressurized air and they must ensure that unskilled and untrained people are restricted and prevented from being nearby any machine that incorporates a UP actuator. Pressurized air is contained within the UP. Pressurized air is supplied to the UP at the pneumatic supply connection point. The I-Port connection point is for the 3 to 15 psi setpoint control signal.

#### DAMAGED AIR LINES (Installation, Commissioning)

- Drive linkage machine guarding is required to prevent potential entanglement injury. Drive linkage motion lockout and lock in-place is required before starting any UP maintenance activity.
- External UP and internal UP leaking, damaged or restricted pneumatic supply lines and fittings can cause sudden unexpected motion of the UP actuator drive arm and linkage mechanisms.



#### ELECTRICAL SHOCK (Installation, Operation)

- UP pneumatic actuators are partial machines in the sense that they are incorporated into a complete machine by system designers and installers. UP actuators require electrical connections, some of the electrical connections are at hazardous voltages.  
UP installers and maintenance people must be aware that hazardous voltages may be used at the UP and they must use the same methods when working with UP actuators. Turn off power voltage sources when performing maintenance activities.

#### EXCESSIVE LOW TEMPERATURES (Installation, Operation)

- UP actuators do not function properly at excessive low temperatures. UP actuator maintenance and service at excessively low temperatures presents additional safety precautions. Ice plugging and unplugging of the pneumatic components can occur at any time causing unexpected motion in the drive mechanism.  
Do not operate or perform UP actuator maintenance at excessively low temperatures.

#### AIR RESERVE TANK CONNECTION (Installation, Operation)

- UP actuators contain pressurized air and use the energy in compressed air to produce the large UP rotational forces. Pressurized air is connected and supplied to the UP during installation. One pressurized air input connection is always supplied with the UP for this purpose. Additional pressurized air connections are required for the UP reserve air tank option.
- Machine designers and installers are reminded that UP actuators contain pressurized air and they must ensure that unskilled and untrained people are restricted and prevented from being nearby any machine that incorporates a UP actuator. Pressurized air is contained within the UP. Pressurized air is supplied to the UP at the pneumatic supply connection point and the optional air reserve tank connection point.

#### LUBRICANT EXPOSURE (Maintenance)

- UP pneumatic actuators include lubricated parts and assemblies. Maintenance activities can expose people to lubricated parts.
- UP actuators include lubricated parts and surfaces.
- Avoid lubricant eye contact, avoid lubricant ingestion, wash exposed areas of skin after lubricant exposure.

#### DRIVE TRAIN COMMISSIONING (Commissioning)

- There are two opposing forces encountered in every integrated machine that incorporates a UP actuator. The UP rotational force is opposed by the process load via the UP drive arm and the interconnecting linkages. Even when the actuator is stationary these large forces are present and acting in opposition. Drive linkage motion lockout and lock in-place is required before starting any UP maintenance activity. External to the UP actuator, that is a partial machine, a set of mechanical linkages are engineered, installed and commissioned by the machine designer and installers.
- Machine designers and installers are cautioned and reminded that they must incorporate safety mechanisms into each machine that includes a UP actuator. If the machine is not locked in place then it could move at any time.

#### UP LEVER ARM PINCH POINTS (Commissioning, Operation)

- Automatic control can cause sudden unexpected motion of the UP actuator drive arm and linkage mechanisms at any time.

#### MACHINE LINKAGE PINCH POINTS (Commissioning, Operation)

- There are two opposing forces encountered in every integrated machine that incorporates a UP actuator. The UP rotational force is opposed by the process load via the UP drive arm and the interconnecting linkages. Even when the actuator is stationary these large forces are present and acting in opposition. Drive linkage motion lockout and lock in-place is required before starting any UP maintenance activity. External to the UP actuator that is a partial machine, a set of mechanical linkages are engineered, installed, and commissioned by the machine designer and installers.
- Machine designers and installers are cautioned and reminded that they must incorporate safety mechanisms into each machine that includes a UP actuator.

#### UNEXPECTED DRIVE MOTION (Commissioning, Operation)

- There are two opposing forces encountered in every integrated machine that incorporates a UP actuator. The UP rotational force is opposed by the process load via the UP drive arm and the interconnecting linkages. Even when the actuator is stationary these large forces are present and acting in opposition. Drive linkage motion lockout and lock in-place is required before starting any UP maintenance activity. External to the UP actuator that is a partial machine, a set of mechanical linkages are engineered, installed and commissioned by the machine designer and installers.
- Machine designers and installers are cautioned and reminded that they must incorporate safety mechanisms into each machine that includes a UP actuator. If the machine is not locked in place then it could move at any time.

#### ENCLOSURE COVERS IN PLACE (Commissioning, Operation)

- There are two opposing forces encountered in every integrated machine that incorporates a UP actuator. The UP rotational force is opposed by the process load via the UP drive arm and the interconnecting linkages. Even when the actuator is stationary these large forces are present and acting in opposition. Drive linkage motion lockout and lock in-place is required before starting any UP maintenance activity. External to the UP actuator which is a partial machine, a set of mechanical linkages are engineered, installed, and commissioned by the machine designer and installers. The UP actuator covers prevent access to the internal UP actuator; there are multiple entanglement and crushing locations within the UP actuator.
- Do not operate the UP actuator without all covers properly installed in place.

#### UP6 MASTER / SLAVE CONNECTION (Commissioning, Operation)

- UP actuators contain pressurized air and use the energy in compressed air to produce the large UP rotational forces. Pressurized air is connected and supplied to the UP during installation. UP6 master slave configurations share additional pressurized air interconnections and mechanical drive linkages that must be coordinated together during machine design and installation.
- Machine designers and installers are reminded that UP actuators contain pressurized air and they must ensure that unskilled and untrained people are restricted and prevented from being nearby any machine that incorporates a UP actuator. Pressurized air is contained within the UP.
- Pressurized air is supplied to the UP at the pneumatic supply connection point. Pressurized air is supplied to the UP6 slave from the UP6 master.

#### AIR SUPPLY NON-COMPLIANCE (Commissioning, Operation)

- UP actuators contain pressurized air and use the energy in compressed air to produce the large UP rotational forces. Pressurized air is connected and supplied to the UP during installation. Air quality requirements and restrictions exist for the UP pressurized air supply.
- Machine designers and installers are reminded that UP actuators use pressurized air and they must ensure that the quality of the pressurized air meets the UP specified installation requirements. Also, the machine designer and installers must provide air quality maintenance processes and procedures for the integrated machine.

#### STORED PNEUMATIC ENERGY (Operation)

- There are two opposing forces encountered in every integrated machine that incorporates a UP actuator. The UP rotational force is opposed by the process load via the UP drive arm and the interconnecting linkages. When stationary, these large forces are present and acting in opposition. Drive linkage motion lockout and lock in-place is required before starting any UP maintenance activity. External to the UP actuator that is a partial machine, a set of mechanical linkages are engineered, installed and commissioned by the machine designer and installers.
- Machine designers and installers are reminded that the UP actuator contains pressurized air energy and they must ensure that unskilled and untrained people are restricted and prevented from being nearby any machine that incorporates a UP actuator.

#### TZIDC POSITIONER LCI CABLE (Operation)

- There are two opposing forces encountered in every integrated machine that incorporates a UP actuator. The UP rotational force is opposed by the process load via the UP drive arm and the interconnecting linkages. Even when the actuator is stationary these large forces are present and acting in opposition. Drive linkage motion lockout and lock in-place is required before starting any UP that is a partial machine, a set of mechanical linkages are engineered, installed and commissioned by the machine designer and installers. UP actuators can be provided with TZIDC positioners that allow maintenance operations with a PC connected with an LCI cable. Typically UP covers are removed for these maintenance operations.
- Maintenance operations with the UP covers removed presents increased crushing hazards. The drive must be locked in place before there is any likelihood of accessing internal UP areas.

#### S-PORT TOO HIGH (Operation)

- UP actuators contain pressurized air and use the energy in compressed air to produce the large UP rotational forces. Pressurized air is connected and supplied to the UP during installation. Input supply pressure must be limited with pressure regulation control. The UP input air pressure limitations must not be exceeded.
- Machine designers and installers are reminded that UP actuators contain pressurized air and they must ensure that the input pressurized air supply is controlled and not exceeded.

#### HEATER HIGH TEMPERATURE (Operation)

- The optional UP heaters are AC line powered. An internal UP temperature sensor controls AC power to the UP heaters.
- Anyone performing maintenance on a UP equipped with internal heaters is reminded that the heaters can be hot and may cause burns. UP maintenance must be performed only when power to heaters is shut off and sufficient time is allowed for the heaters to cool.

#### TRIP HAZARDS (Operation)

- UP pneumatic actuators are partial machines in the sense that they are incorporated into a complete machine by system designers and installers. UP actuators require mechanical linkage mechanical design and safeguarding as well as the connection of pneumatic supply lines and electrical cables.
- UP system machine designers and installers must take precautions to limit trip hazards and obstructions caused by mechanical linkages and their safeguards, as well as pneumatic and electrical line connections.

#### UP / DOWN CAPACITY FAILURE (Operation)

- There are two opposing forces encountered in every integrated machine that incorporates a UP actuator. The UP rotational force is opposed by the process load via the UP drive arm and the interconnecting linkages. The UP rotational force is developed from pressurized air stored in the UP actuator. Even when stationary large forces are present and acting in opposition and pressurized air is contained within the UP actuator. From a safety consideration viewpoint the drive can move at any time when it is not locked in place. But, under normal automatic control operation, the UP actuator is expected to only make small, infrequent position adjustments. Control action where the drive position is noticeably continuously modulating with larger than expected rotational movements is not normal and is likely to be the result of equipment failure. Air leakage within the UP pneumatic piping and pneumatic components effects the ability of the UP actuator to regulate smooth modulation-free control action.
- Air leakage failures and pneumatic piping restrictions can severely affect the UP actuator's functionality and cause unexpected motion and oscillations in the drive.

#### MANUAL HAND OPERATION (Operation, Repair Maintenance)

- Automatic control can cause sudden unexpected motion of the UP actuator drive arm and linkage mechanisms at any time. Drive linkage machine guarding is required to prevent potential entanglement injury. Drive linkage motion lockout and lock in-place is required before starting any UP maintenance activity.
- Consult the UP Actuator Service Manual for further information on performing drive motion lockout and lock in-place for the UP actuators.

#### AIR VENTING NOISE (Preventative Maintenance)

- There are two opposing forces encountered in every integrated machine that incorporates a UP actuator. The UP rotational force is opposed by the process load via the UP drive arm and the interconnecting linkages. The UP rotational force is developed from pressurized air stored in the UP actuator. Even when stationary large forces are present and acting in opposition and pressurized air is contained within the UP actuator.
- Machine designers and installers are reminded that the UP actuator contains pressurized air energy and they must ensure that unskilled and untrained people are restricted and prevented from being nearby any machine that incorporates a UP actuator. In addition, skilled and knowledgeable maintenance people must be aware of the loud noise that can accompany the release to atmosphere of pressurized air that can occur at any time or in response to maintenance actions.

#### MACHINE SAFETY CATCH (Repair Maintenance)

- Automatic control can cause sudden unexpected motion of the UP actuator drive arm and linkage mechanisms at any time. Drive linkage machine guarding is required to prevent potential entanglement injury. Drive linkage motion lockout and lock in-place is required before starting any UP maintenance activity.
- Consult the UP actuator operating instruction manual for further information on performing drive motion lockout and lock in-place for the UP actuators.

#### WEIGHT OF REPLACEMENT COMPONENTS (Repair Maintenance)

- Internal UP actuator space is a confined space for maintenance and component replacement activities. The components in the larger UP actuators are heavy and confined in a relatively small space. Maintenance in the confined space and weight of the components must be approached with caution and avoidance of hand and foot crushing injuries.
- Consult UP actuator service manual for detailed component replacement information.

#### OPERATING TOOL USEAGE (Repair Maintenance)

- Mechanical ratchets are provided with the UP3 through UP7 that are used to move the drive position manually. The UP3 through UP7 enclosure includes a storage location for the manual ratchet. No ratchets are provided for the UP1 and UP2. When fully integrated into a process control damper drive environment the ability and time required to reposition the UP manually is an application consideration that could effect plant operations.
- UP drives can be repositioned manually using mechanical means at the UP. When performing UP repositioning by these manual mechanical methods ensure the procedures in the UP service manual are followed.

#### SHARP EDGES (Repair Maintenance, Disassembly)

- Integrated UP machines must be safeguarded adequately by the machine designer and machine installer.
- Internal UP maintenance exposes numerous pinch points and some sharp edges for maintenance personnel. Drive linkage motion lockout and lock in place is required before starting any UP maintenance activity.

## 3 Installation

### 3.1 Introduction

This section contains procedures for unpacking, inspecting, locating and safety considerations. There are also instructions for setup and physical installation, including wiring, cabling and tubing connections. Finally, it covers connections for optional equipment and any adjustments that make the unit operational.

### 3.2 Unpacking and Inspection

Before unpacking, check the outside of the shipping carton for signs of in-transit damage. Pay particular attention to punctures, tears or other damage to the outer carton. Look for signs of water damage. If damaged, notify the carrier and ABB immediately. Check the data on the nameplate, located on the actuator mounting frame. Ensure the unit is suited for the required application.

### 3.3 Location considerations

---

#### **i** NOTICE – Property damage

Protect the air lines and equipment from freezing in temperatures below 0°C (32°F). Failure to do so can damage the equipment.

---

Locate the actuator according to the linkage arrangement required (refer to Connecting Linkage for Universal Rotary Actuators – refer to Appendix 4.1). For dimensions and required clearances, refer to the dimension drawings.

Actuators are designed for use in ambient temperatures of - 40 to 82°C (-40 to 180°F) (see Note 1). Unless using air dryers or heaters, impose a low temperature operating limit of 0°C (32°F).

**Note 1.** Some actuator / positioner combinations may have a different maximum and different minimum operating temperature. Refer to Type AV, TZIDC or EDP300 specification for temperature limitations. Consult the factory for UP3 to UP6 minimum positioner ambient temperature limit when using internal strip heater option. The positioner is inside the heated enclosure for UP3 to UP6 therefore, as long as the heaters function with the covers in place, the positioner is not exposed to the ambient temperature. Therefore, the positioner minimum ambient temperature can often be exceeded. Consult the factory for details.

### 3.4 Enclosure removal



#### **WARNING – Bodily injury**

Do not operate this equipment unless the covers are in place. The covers prevent access to moving components that pose a risk of entanglement of body parts.

---

Use the enclosure removal procedures in this section to access components for wiring / tubing installation, calibration, maintenance, repair and replacement.

#### 3.4.1 Type UP1 actuator

Type UP1 actuators do not have an enclosure; the positioner and / or travel switch mount to the UP1 frame. To access the positioner, position transmitter or travel switch terminals for field wiring, remove the positioner cover and/or the travel switch cover.

Refer to Fig. 3.1 for UP1 with AV positioner.

Refer to Fig. 3.2 for UP1 with TZIDC positioner.

Refer to Fig. 3.3 for UP1 with EDP300 positioner.

Refer to TZIDC, EDP300 or AV manual for wiring details (refer to Appendix A.1).

#### 3.4.2 Type UP2 actuator

The Type UP2 actuator with AV, TZIDC or EDP300 positioner and travel switches require the covers of the positioner and the travel switch assembly to be removed to access the field wiring terminals.

The Type UP2 actuator has a removable side panel and top cover.

Refer to Fig. 3.4, for UP2 with AV positioner.

Refer to Fig. 3.2 for UP2 with TZIDC positioner.

Refer to Fig. 3.3 for UP2 with EDP300 positioner.

1. There are six side panel screws that hold the side panel to the actuator frame. Remove these six screws.
2. Remove the side panel.
3. There are four link lock fasteners that secure the top cover to the actuator – two on each side near the top of the actuator. Unsnap the link lock fasteners.
4. Remove the top cover.

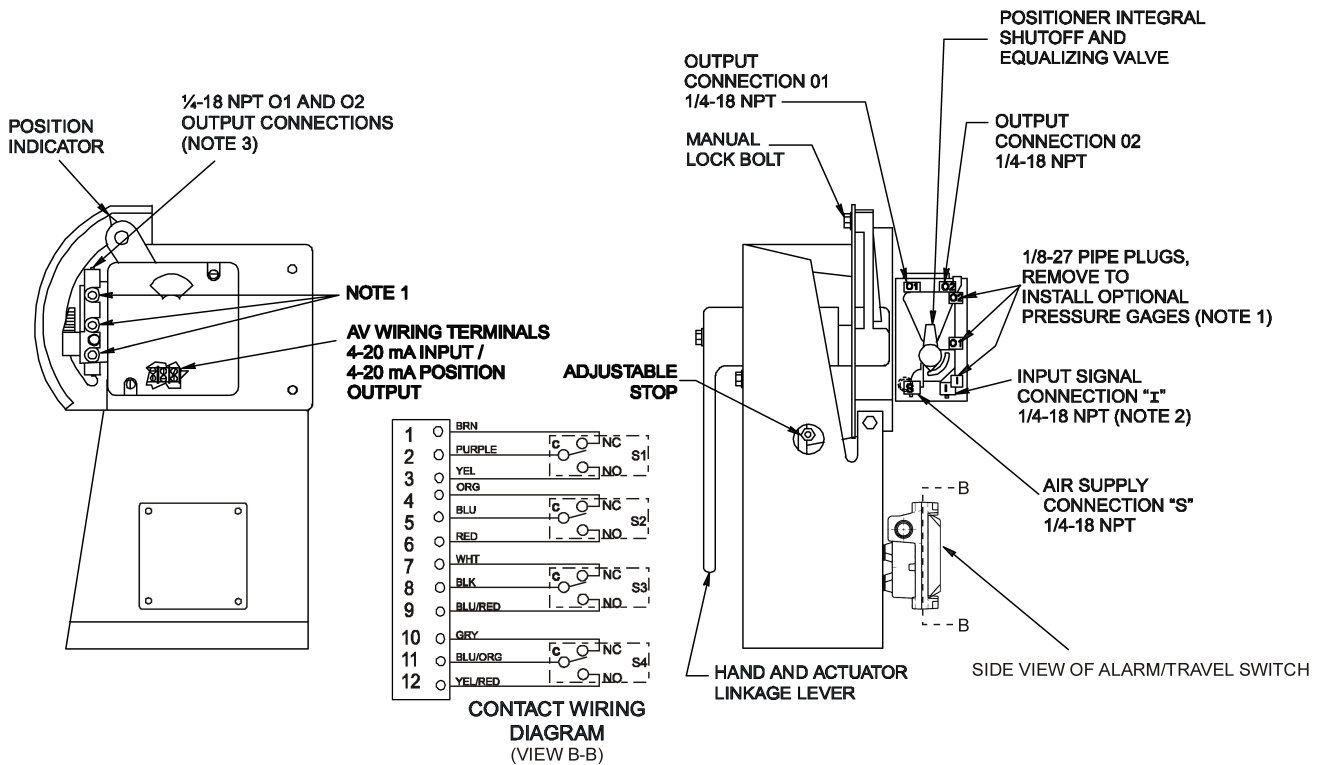

- NOTES:**
- PRESSURE GAGES ARE AVAILABLE ONLY AS ACCESSORIES AND MUST BE INSTALLED BY THE CUSTOMER.
  - FOR UP1#A, 21-103 KPA (3-15 PSIG); FOR UP1#B, 21-186 KPA (3-27 PSIG); PLUGGED FOR UP1#C, UP1#D.
  - THE UNIVERSAL ACTUATOR IS NORMALLY SUPPLIED WITH THE TUBING CONNECTIONS FOR DIRECT LOADING. FOR REVERSE LOADING APPLICATIONS. WITH AV POSITIONERS, REVERSE THE AIR LINES AT THE POSITIONER PORTS O1 AND O2 AND INSTALL REVERSE ACTING POSITIONER CAM. WITH TZID-C POSITIONERS (NOT SHOWN), CHANGE THE CONFIGURATION AS DESCRIBED IN THE TZID-C INSTRUCTION MANUAL.

TP20103C\_1

Fig. 3.1: Type UP1 actuator with type AV positioner and optional alarm / travel switch (drawing no. TP20103C\_1)

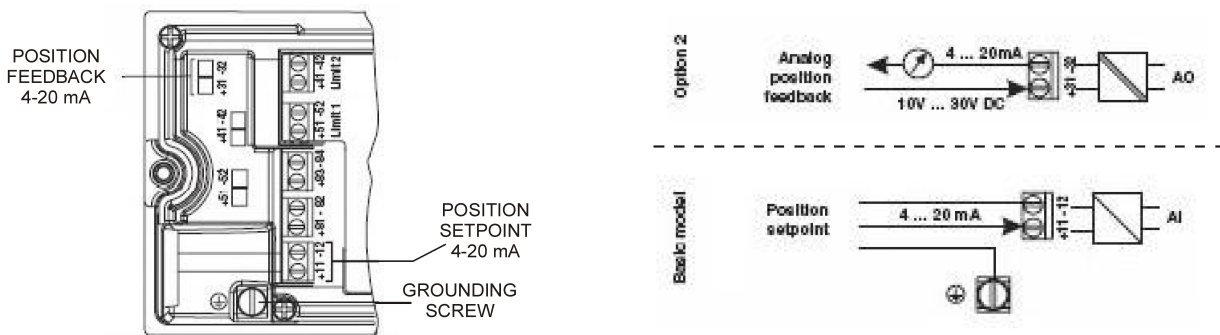

Ref: TZIDC\_DS\_1

Fig. 3.2: TZIDC wiring diagram (drawing no. Ref: TZIDC\_DS\_1)

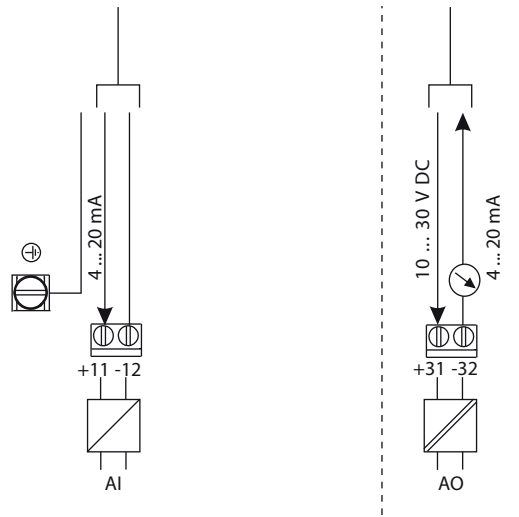

Fig. 3.3: EDP300 wiring diagram (drawing no. Ref: TZIDC\_DS\_1)

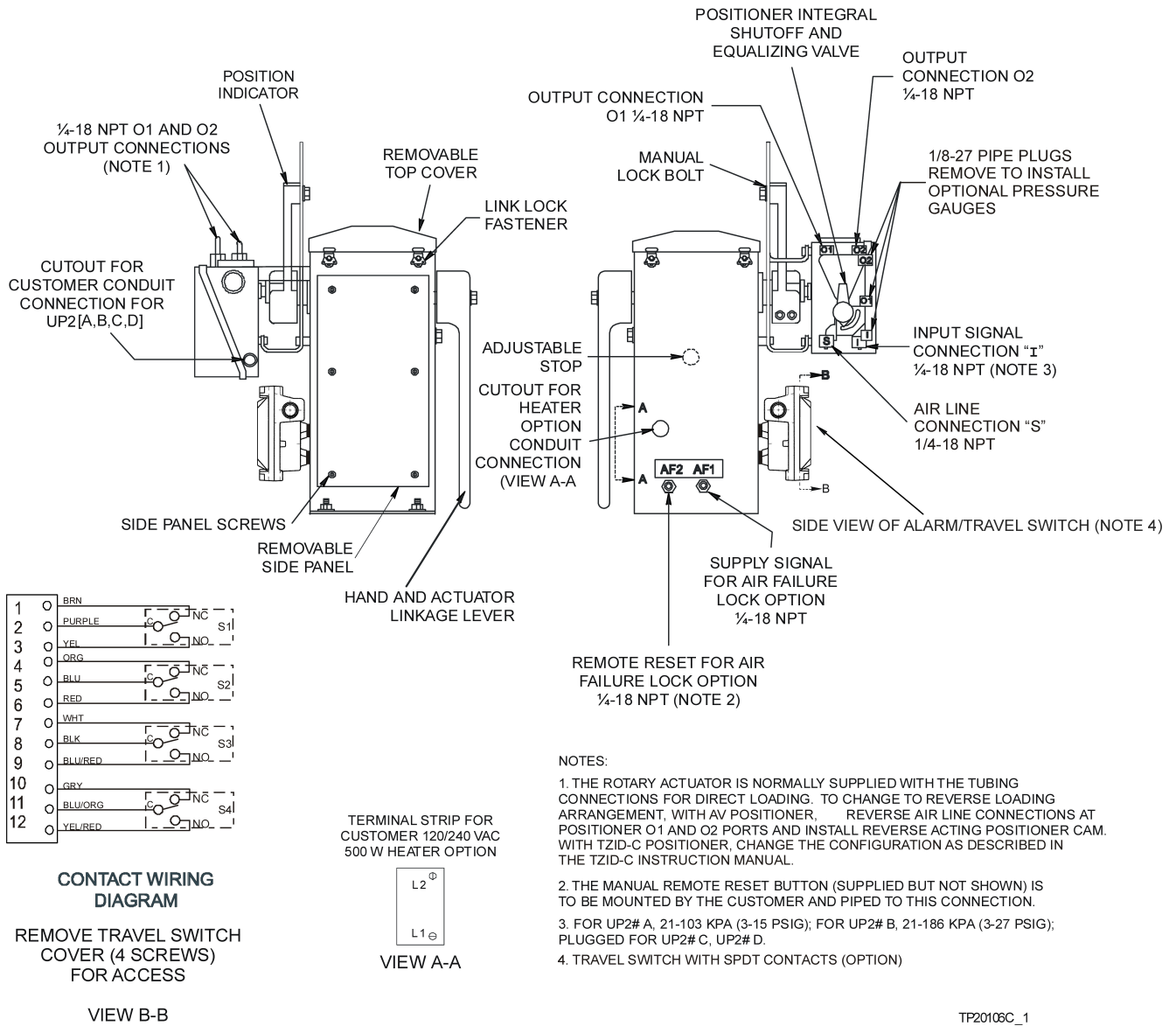

Fig. 3.4: Type UP2 actuator with type AV positioner and optional alarm / travel switch (drawing no. TP20106C\_1)

### 3.4.3 Types UP3 and UP4 Actuator

The Types UP3 and UP4 actuators have two removable side covers and a removable top cover.

Referring to Fig. 3.5:

1. There are 6 side panel screws that hold the side panel to the actuator frame. Remove these 6 screws.
2. Release the link lock fasteners that secure the top cover to the side covers.
3. Release the link lock fasteners that secure the side covers to the actuator frame. Remove the side covers by pulling down and outward from the bottom.
4. There are 4 link lock fasteners that secure the top cover to the actuator – two on each side near the top of the actuator. Unsnap the link lock fasteners.
5. Unsnap the link lock fasteners holding the top cover to the side covers.
6. Remove the top cover.

### 3.4.4 Types UP5, UP6 and UP7 Actuator

Types UP5, UP6 and UP7 actuators have removable bottom side covers, top side covers and a removable top cover.

Referring to Fig. 3.6:

1. Loosen the bottom side cover bolts.
2. Unfasten the link lock fasteners that secure the bottom side covers to the top side covers.
3. Remove the bottom side covers by pulling down and outward on the panel.
4. Unsnap the link lock fasteners that secure the top cover to the top side covers.
5. Remove the top cover.
6. Remove the bottom side covers and top cover.
7. On the cylinder side of the actuator, loosen the top side cover bolts and lift the panel outward.
8. On the other side of the actuator, remove the manual operator ratchet handle and hand / auto transfer handle.
9. Loosen the top side cover bolts and lift the panel outwards.



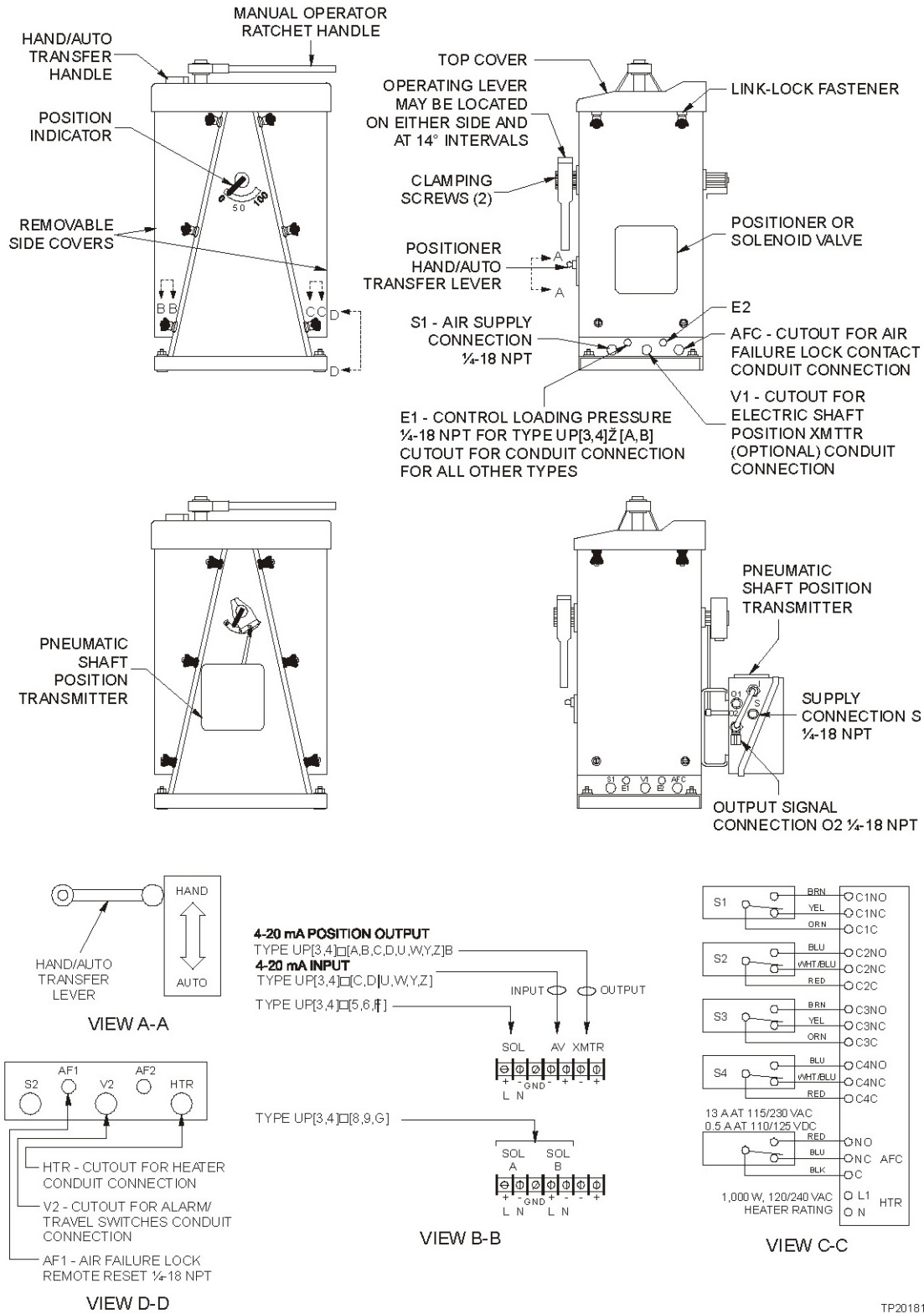

TP20181C\_1

Fig. 3.5: Types UP3 and UP4 actuators (drawing no. TP20181C\_1)

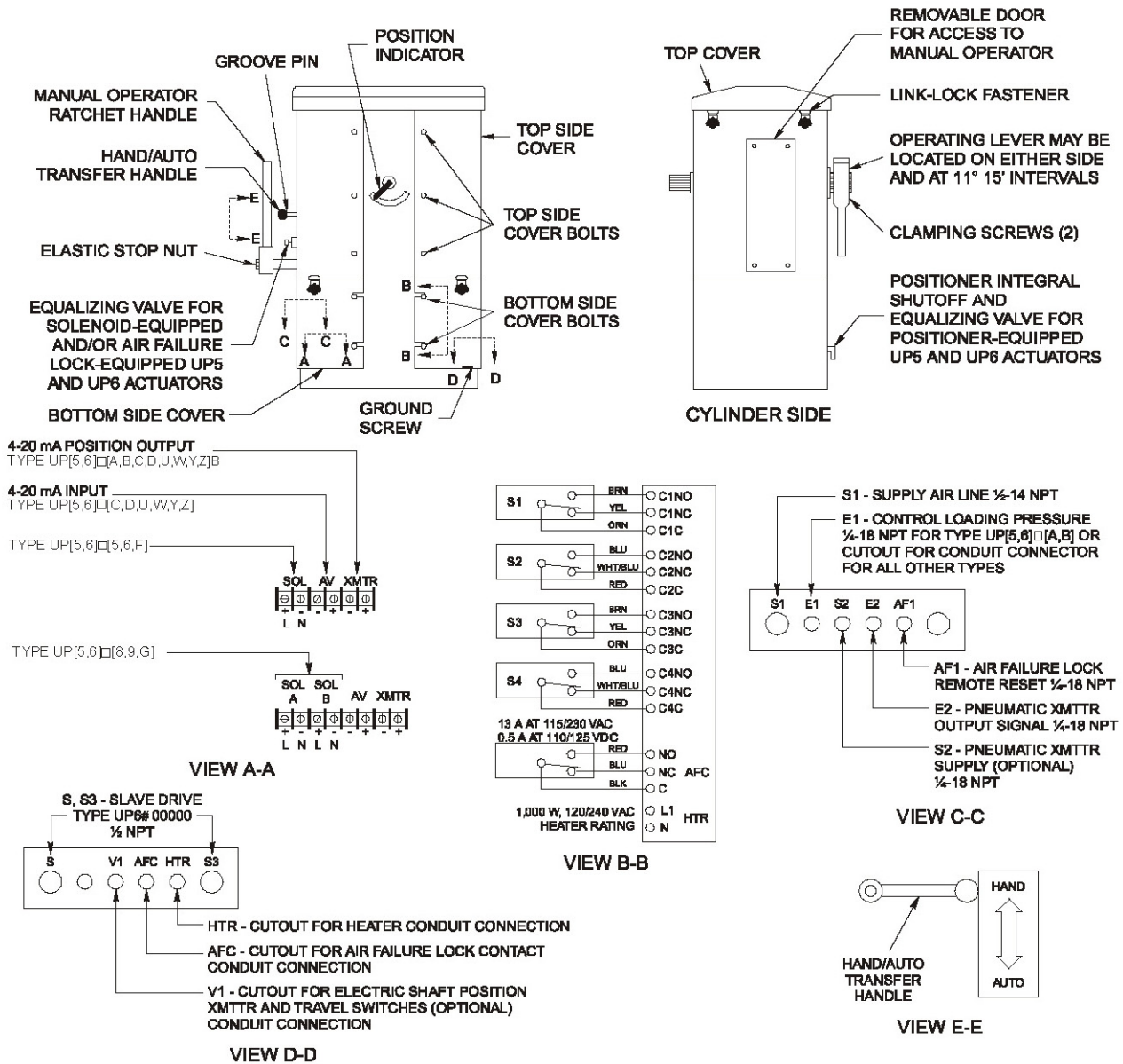

TP20107C\_1

Fig. 3.6: Types UP5, UP6 and UP7 actuators (drawing no. TP20107C\_1)

### 3.5 Wiring connections, tubing connections and cabling

These procedures describe wiring, tubing and cabling necessary to operate the actuators. Also refer to Section 3.4 and related figures.

#### 3.5.1 Connecting tubing

Use suitable fittings and tubing sizes according to the UP Service manual.

Refer to Table 3.2 for recommended maximum operating torque values versus minimum and maximum supply pressure. Keeping supply pressure at  $\pm 5\%$  of the selected pressure requires no further supply regulation.

**Note.** The primary units in these graphs are Newton meters and kilo pascals. Imperial units are in parentheses.

Installing a regulator with a flow capacity greater than (or equal to) those listed in Table 3.1 protects the driven device. It also prevents exceeding the maximum supply or operative limit of the actuator.

Maximum supply pressure for UP actuators with TZIDC positioners is 90 psig.

Actuator type	Min. supply line size (in.)	Signal line size (in.)	Filter regulator part no.	Air regulator part no.	Air Filter regulator part no.	Capacity m <sup>3</sup> /s (scfm)
UP1	¼	¼	5328563_2	1951029_5		1.27 (45)
UP2						
UP3	½	¼			1951439_1	1.13 (40)
UP4						
UP5						
UP6						
UP7						

Table 3.1: Tubing sizes and air filter regulator

Actuator type	Min. and Max. supply pressure* kPa (psig)	Max operating torque Nm (ft-lbs)
UP1	276 (40)	54 (40)
	620 (90)	110 (81)
	690 (100)	122 (90)
UP2	276 (40)	224 (165)
	620 (90)	550 (405)
	690 (100)	610 (450)
UP3	276 (40)	441 (325)
	620 (90)	976 (720)
	690 (100)	1,085 (800)
UP4	276 (40)	746 (550)
	620 (90)	1,770 (1,305)
	690 (100)	1,966 (1,450)
UP5	276 (40)	1,437 (1,060)
	620 (90)	3,417 (2,520)
	690 (100)	3,796 (2,800)
UP6	276 (40)	2,576 (1,900)
	620 (90)	5,857 (4,230)
	690 (100)	6,372 (4,700)
UP7	276 (40)	3,663 (2,702)
	552 (80)	7,326 (5,403)

Table 3.2: Recommended operating torque at minimum and maximum supply pressure limits

#### 3.5.2 Connecting wiring

Ensure all wiring and electrical connections comply with local regulations.

#### 3.5.3 Grounding

It is the responsibility of the customers and / or their installation / wiring contractor to ensure that the actuator, other associated control or test equipment and all exposed conductive materials are grounded correctly. In addition, ensure that they are not a hazard, including under fault conditions, to operation and service personnel.

#### 3.5.4 Air quality

**Note.** Installing a filter in the air supply line prevents moisture or dirt from entering the positioner.

1. Use only clean dry instrument air as the supply.
2. Keep the oil content of the air as low as possible, with a maximum of 1 ppm.
3. Particle size in the air must not exceed 3 microns for UP actuators equipped with AV positioner and 5 microns for UP actuators equipped with TZIDC or EDP300 Positioners.
4. Keep the dew point at line pressure at least 10°C (18°F) below minimum ambient temperature (characterizable pneumatic positioner tubing).

### 3.5.5 Characterizable pneumatic positioner tubing

Tubing for the Type AV1 characterizable pneumatic positioner differs slightly depending on the actuator. If the actuator supplied includes the air failure lock, refer to Air failure lock tubing.

#### Types UP1 and UP2 actuators

Referring to Figs. 3.1, 3.2 and 3.4:

1. Connect the supply pressure line directly to the S port on the positioner.
2. Connect the control loading pressure directly to the I-Port on the positioner (pneumatic input only).

#### Types UP3 and UP4 actuators

Referring to Fig. 3.5:

1. Connect the supply pressure line directly to the S1 port at the base of the actuator.
2. Connect the control loading pressure directly to the E1 port at the base of the actuator (pneumatic input only).

#### Types UP5 and UP6 actuators

Referring to Fig. 3.6:

1. Connect the supply pressure line directly to the S1 port at the base of the actuator.
2. Connect the control loading pressure directly to the E1 port at the base of the actuator (pneumatic input only).

### 3.5.6 Characterizable I/P positioner tubing and wiring

Tubing for Types AV, TZIDC and EDP300 positioners differs slightly, depending on the actuator. If the actuator supplied includes the air failure lock, refer to Air failure lock tubing.

#### Types UP1 and UP2 actuators

Referring to Figs. 3.1, 3.2, 3.3 and 3.4:

1. Connect the supply pressure line directly to the S port on the positioner.
2. The I-Port is plugged for UP actuators equipped with AV2, TZIDC and EDP300 Positioners.
3. There is a conduit connection on the side of the positioner housing for signal wiring with a cross-sectional area of 0.32 to 1.30 mm<sup>2</sup> (22 to 16 AWG) for AV series positioners and 2.5 mm<sup>2</sup> for TZIDC and EDP300 series positioners. Use a twisted, shielded pair for signal wiring.

#### Types UP3 and UP4 actuators

Referring to Fig. 3.5:

1. Connect the supply pressure line directly to the S1 port at the base of the actuator.
2. A conduit connection, E1, is provided at the actuator base for signal wiring to the positioner. All power to the positioner is supplied over the signal wiring. Use shielded or non shielded wire with a cross-sectional area of 0.2 to 2.1 mm<sup>2</sup> (24 to 14 AWG) for the control signal to the positioner.
3. Remove the side cover on the positioner side of the actuator as described in Section 3.4.
4. Feed the wires through the conduit connection and connect them to the terminal block AV+ and AV- positions.
5. Replace the side cover.

#### Types UP5 UP6 and UP7 actuators

Referring to Fig. 3.6:

1. Connect the supply pressure line directly to the S1 port at the base of the actuator.
2. A conduit connection (E1) is provided at the actuator base for signal wiring to the positioner. All power to the positioner is supplied over the signal wiring. Use shielded or non shielded wire with a cross-sectional area of 0.2 to 2.1 mm<sup>2</sup> (24 to 14 AWG) for the control signal to the positioner.
3. Remove the bottom side cover as described in Section 3.4.
4. Feed the wires through the conduit connection and connect them to the terminal block AV+ and AV- positions.
5. Replace the side cover.

### 3.5.7 Solenoid tubing and wiring

Solenoid tubing and wiring differs slightly depending on the actuator. If the actuator supplied includes the air failure lock, refer to Section 3.6.2.

#### Types UP1 and UP2 actuators

Referring to Figs. 3.7 and 3.8:

1. Types UP1 and UP2 actuators have a conduit connection provided on the solenoid valve for electrical hook-up.
2. The solenoid wires (AC or DC) have no color coding or polarity markings. Use either wire for positive (+).
3. Connect the supply pressure line directly to the P-port on the solenoid valve.
4. Connect a grounding wire to the termination provided.

#### Types UP3 and UP4 actuators

Referring to Fig. 3.5:

1. Connect the supply pressure line directly to the S1 port at the base of the actuator.
2. A conduit connection (E1) is provided at the actuator base for solenoid valve wiring (AC or DC).
3. Remove the side cover on the solenoid side of the actuator as described in Section 3.4.
4. Feed the wires through the conduit connection and connect them to the terminal block solenoid positions. The solenoid wires are not color coded or marked for polarity. Either wire can be used for positive (+).
5. Connect a grounding wire to the termination provided.
6. Replace the side cover.

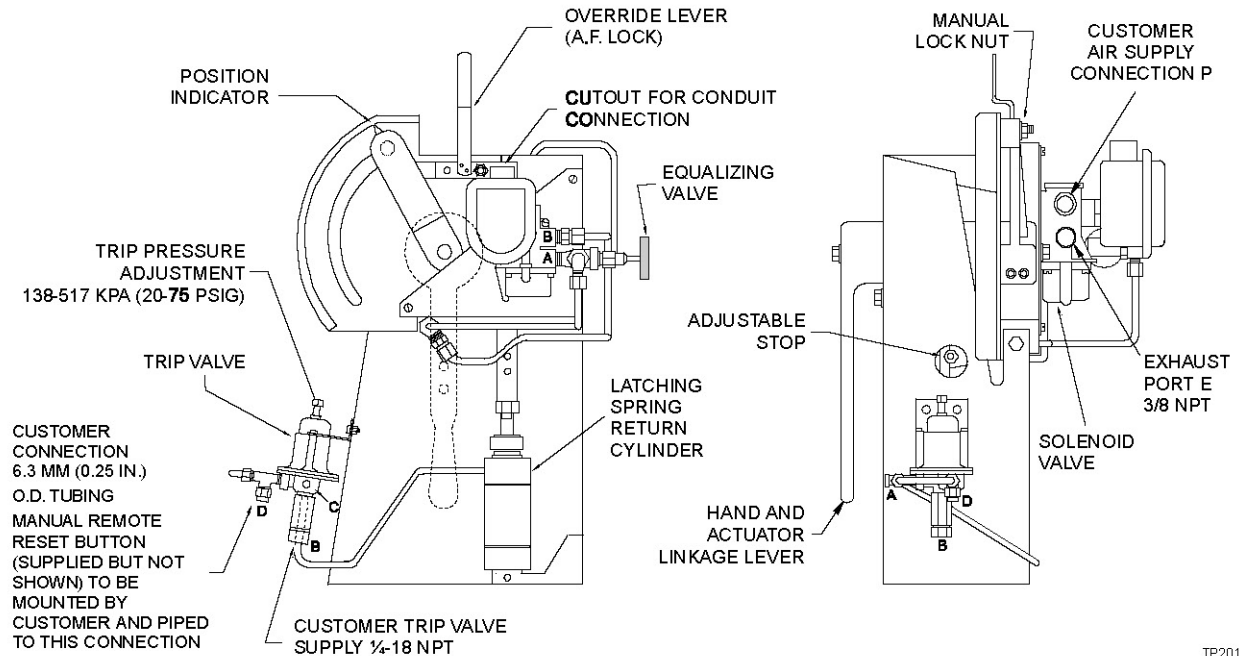

Fig. 3.7: Type UP1 actuator with solenoid valve and air failure lockup (drawing no. TP20102B\_1)

## Types UP5 UP6 and UP7 actuators

Referring to Fig. 3.6:

1. Connect the supply pressure line directly to the S1 port at the base of the actuator.
2. A conduit connection (E1) is provided at the actuator base for solenoid valve wiring (AC or DC).
3. Remove the bottom side cover on the solenoid side of the actuator as described in Section 3.4.
4. Feed the wires through the conduit connection and connect them to the terminal block solenoid positions. The solenoid wires are not color coded or marked for polarity. Either wire can be used for positive (+).
5. Connect a grounding wire to the termination provided.
6. Replace the bottom side cover.

### 3.5.8 Master / Slave tubing connections for Type UP6 actuators

**Note.** This installation requires the use of an installation kit (supplied as part of the slave drive), kit number 258458\_1.

Referring to Fig. 3.9:

1. To drive a common load, connect the master and slave actuators in parallel.
2. Ensure both actuators are aligned correctly so they operate together, without binding, throughout the stroke.
3. The total volume displacement for both actuators is 41,200 cm<sup>3</sup> (2,514 in.<sup>3</sup>).
4. A supply delivery capacity of 11,800 cm<sup>3</sup>/s (25 scfm) or more is required, unless some decrease in stroke speed can be allowed.
5. Connect the supply air line directly to the S1 port at the base of the master actuator.
6. Refer to Section 3.4 and remove the top and side covers of the master actuator.
7. If the master actuator has the air failure lock option, perform Steps 8 to 11. If the master actuator does not have the air failure lock option, proceed to Step 12.
8. Remove the bypass valve air line fittings from the tees in the cylinder air lines.
9. Install a second female tee into the two existing tees using the close nipples (supplied).

10. Connect the bypass valve air lines to one of the open ports in each added tee.

11. Proceed to Step 13.

12. Remove the pipe plugs from the tees in the cylinder air lines.

13. Install two bulkhead fittings in the two available conduit knockouts at the base of the master. The knockouts have ½-14 NPT internal threads.

14. Connect ½ in. OD nylon tubing between each bulkhead fitting and the tees in the cylinder air lines using the 4 elbow tube fittings supplied.

15. Route and tie down the tubing so it clears all moving parts.

16. Label the bulkhead fittings to identify the one that tees into the top of the cylinder and the one that tees into the bottom of the cylinder. The external ends of the bulkhead fittings are female ½ in. NPT.

17. Use ½ in. minimum air lines to connect the master and slave actuators.

18. Hook up the two air lines connecting the master and slave actuators so cylinder forces (output torques) aid each other. Polarity of this connection varies for each installation. It depends on the physical setup of the actuators and how the linkage connects.

19. On the slave actuator, S1 goes to the top of the cylinder, and S3 goes to the bottom of the cylinder.

Increased pressure on the top of the cylinder causes the output shaft on the left side (when facing the hand crank end) to rotate counter clockwise. Rotation on the master actuator is the same. Increased pressure on the bottom of the cylinder causes the output on the right side (when facing the hand crank end) to rotate clockwise. Rotation on the master actuator is the same.

To change from direct to reverse loading, refer to Section 3.7.1, page 43.

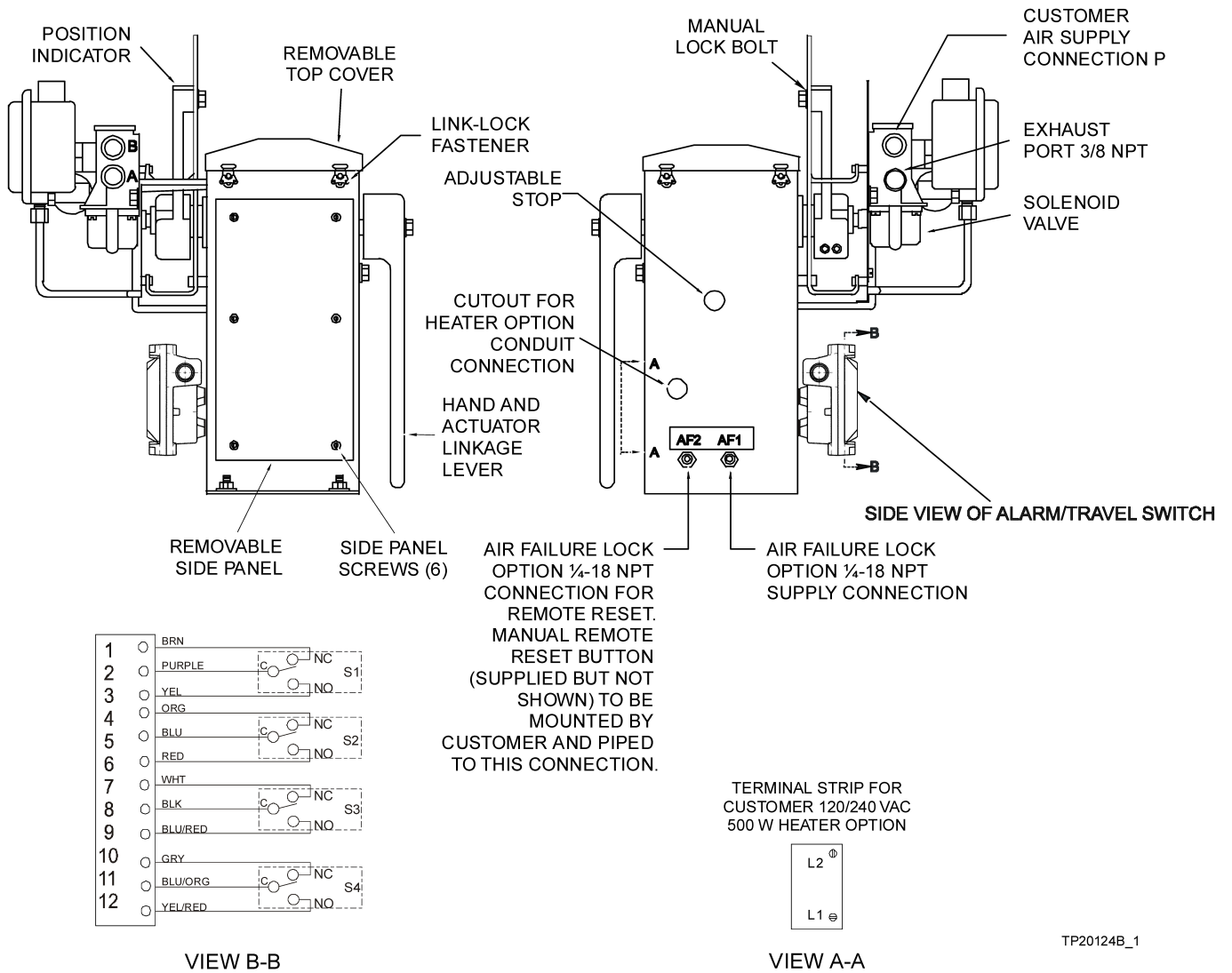

TP20124B\_1

Fig. 3.8: Type UP2 actuator with solenoid (drawing no. TP20124B\_1)

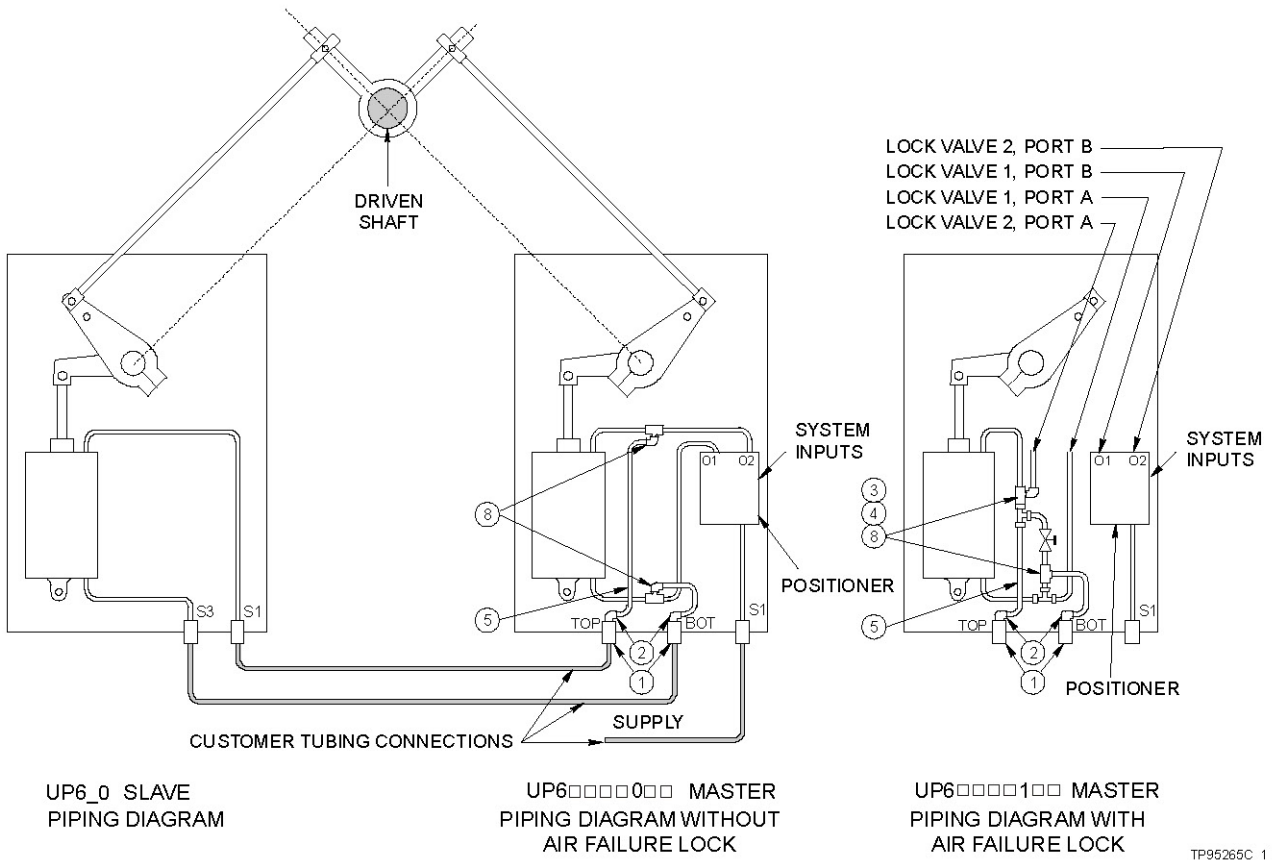

Fig. 3.9: Master / Slave tubing connections (drawing no. TP95265C\_1)

Item	Qty	Part No.
1	2	1952621_1
2	2	8-8CBI2-B
3	2	-----
4	2	-----
5	2	R9021-0050
8	2	5323705_1

Table 3.3: Master / Slave installation kit (kit part no. 258458\_1)



### 3.6 Installation of optional equipment

These procedures describe the tubing, wiring and cabling necessary to make the various options operable.

#### 3.6.1 Reserve air tank tubing and wiring

**Note:** The reserve air tank option is not available for Type UP1 actuators.

All tubing connections inside the actuator for the optional reserve air tank are completed before despatch. External tubing consists of connecting the air tank to the supply air line and actuator.

#### Type UP2 actuators

Referring to Fig. 3.10:

1. Securely install the reserve air tank as close to the actuator as possible in a vibration-free location where the reserve air tank and air lines are not damaged.
2. Using ¼ in. OD tubing, connect the customer air supply to the tee fitting at the S port on the positioner or the P port on the solenoid valve.
3. Using ¼ in. OD tubing, connect the inlet port on the reserve air tank to the check valve fitting on the positioner or solenoid valve.
4. Using ¼ in. OD tubing, connect the outlet port on the reserve air tank to the 1B or 2B port on the lock valve. The output shaft of the actuator can be rotated to either the 0% or 100% position with either connection.

**Note.** The unused B port must remain open to vent air.

5. A designation label is supplied with the reserve air tank kit. One half is marked 0% and the other half is marked 100%. Cut the label in half and apply the 0% and 100% labels below the bulkhead fittings on the actuator frame that correspond to the 0% and 100% output shaft travel limits.
6. An optional alarm pressure switch and terminal block are installed inside the actuator for an external air failure alarm or indicator, Refer to Type UP2 Actuator and remove the cover necessary to access the terminal block.
7. Run the wires for the external alarm through one of the holes in the actuator enclosure and connect them as shown in Fig. 3.10.
8. Replace the actuator cover.

#### Types UP3 to UP7 actuators

Referring to Fig. 3.12:

1. Securely install the reserve air tank as close to the actuator as possible in a vibration-free location where the air tank and air lines will not be damaged.
2. Using ½ in. OD tubing, connect the customer air supply directly to the S1 port on the actuator.
3. Using ½ in. OD tubing, connect the inlet port on the reserve air tank to the S2 port on the actuator.
4. Using ¼ in. OD tubing, connect the outlet port on the reserve air tank to the actuator. Select one of the following:

For the cylinder piston to be driven to the fully down position upon loss of pressure from the supply line, connect to the CYL DN port on the actuator.

**Note.** The CYL UP connection must remain open to vent air from the bottom of the cylinder.

or

For the cylinder piston to be driven to the fully up position upon loss of pressure from the supply line, connect to the CYL UP port on the actuator.

**Note.** The CYL DN connection must remain open to vent air from the top of the cylinder.

5. An optional alarm pressure switch and terminal block are installed inside the actuator for an external air failure alarm or indicator. Refer to Types UP3 and UP4 actuator or Types UP5 and UP6 actuator enclosure and remove the covers necessary to access the terminal block.
6. A conduit connection (AFC) is provided at the actuator base for access to the air failure contacts. Feed the wiring through this connection.
7. Make the connections to the appropriate points on the terminal strip as shown in Fig. 3.12.
8. Replace the actuator covers.

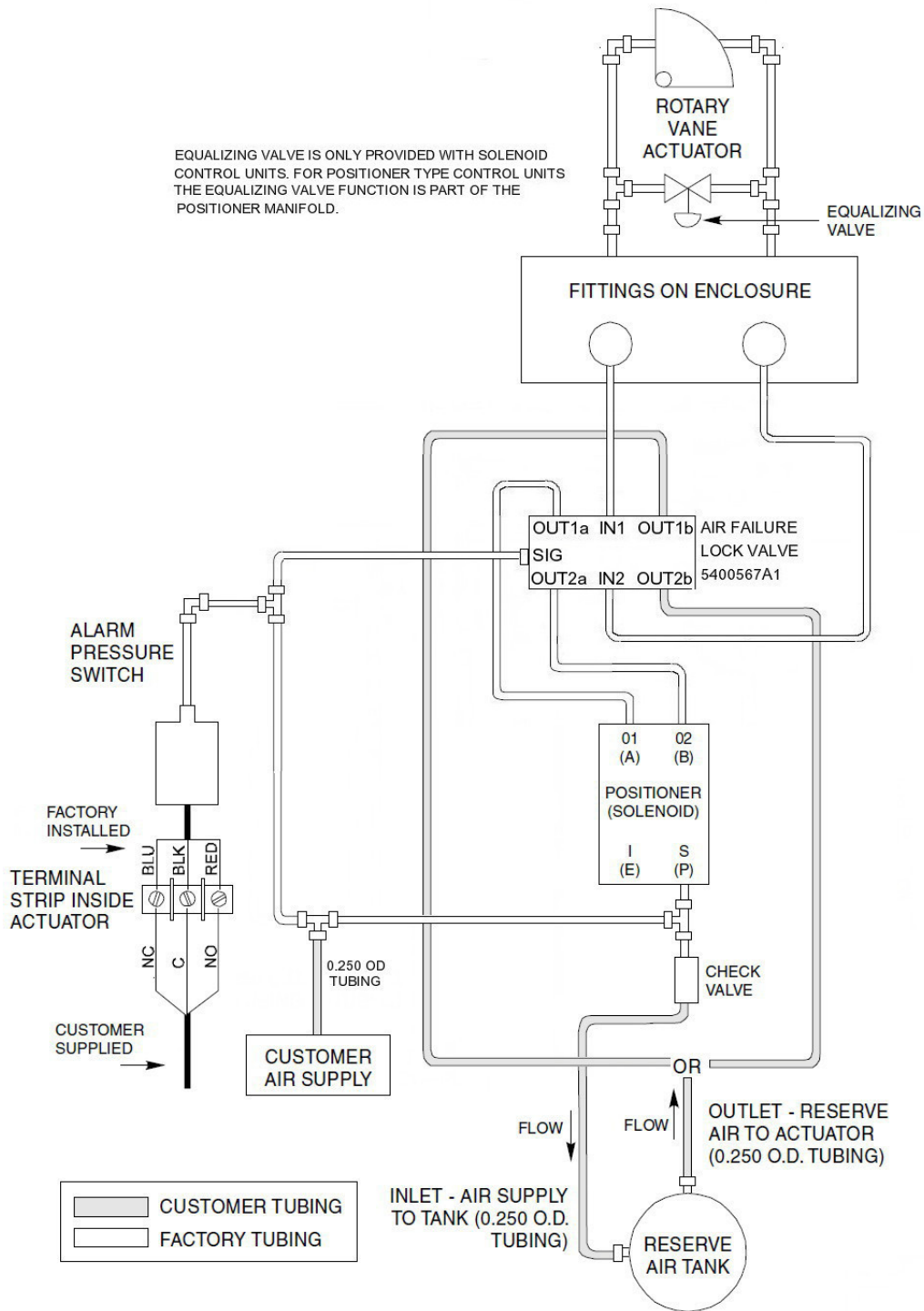

AIR FAILURE CONTROL = 4 FOR UP2

AIR FAILURE CONTROL = '4' MEANS RESERVE AIR TANK, ACTUATOR GOES TO 0 OR 100% (FIELD SELECTABLE) UPON LOSS OF AIR SUPPLY, WITH PRESSURE SWITCH FOR AIR FAILURE ALARM.

TPSC2015UP\_7

Fig. 3.10: Reserve air tank tubing for Type UP2 actuator (with alarm pressure switch)

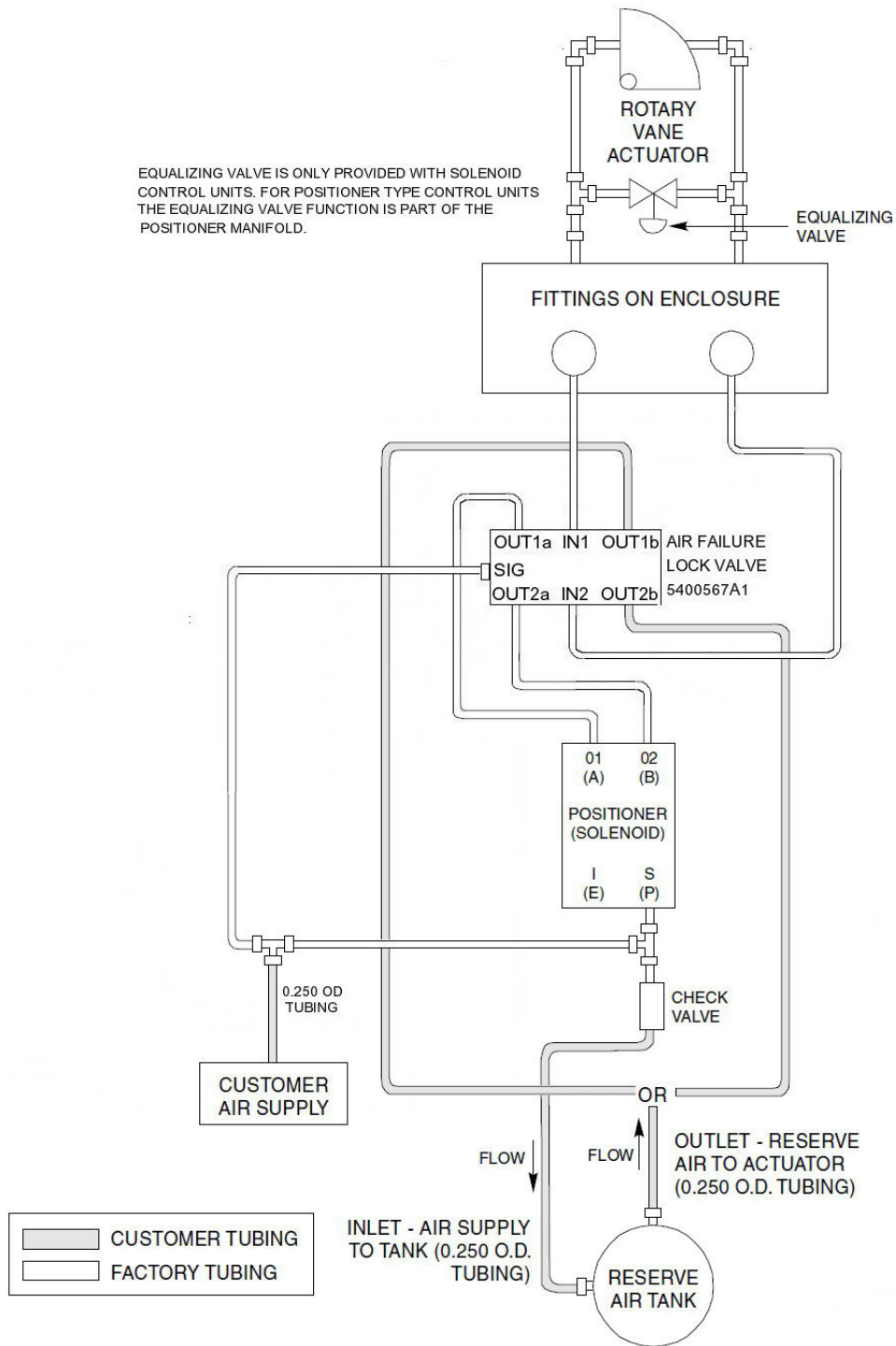

AIR FAILURE CONTROL = C FOR UP2

AIR FAILURE CONTROL = 'C' MEANS RESERVE AIR TANK, ACTUATOR GOES TO 0 OR 100% (FIELD SELECTABLE) UPON LOSS OF AIR SUPPLY, WITHOUT PRESSURE SWITCH FOR AIR FAILURE ALARM.

TPSC2015UP\_8

Fig. 3.11: Reserve air tank tubing for Type UP2 actuator (without alarm pressure switch)

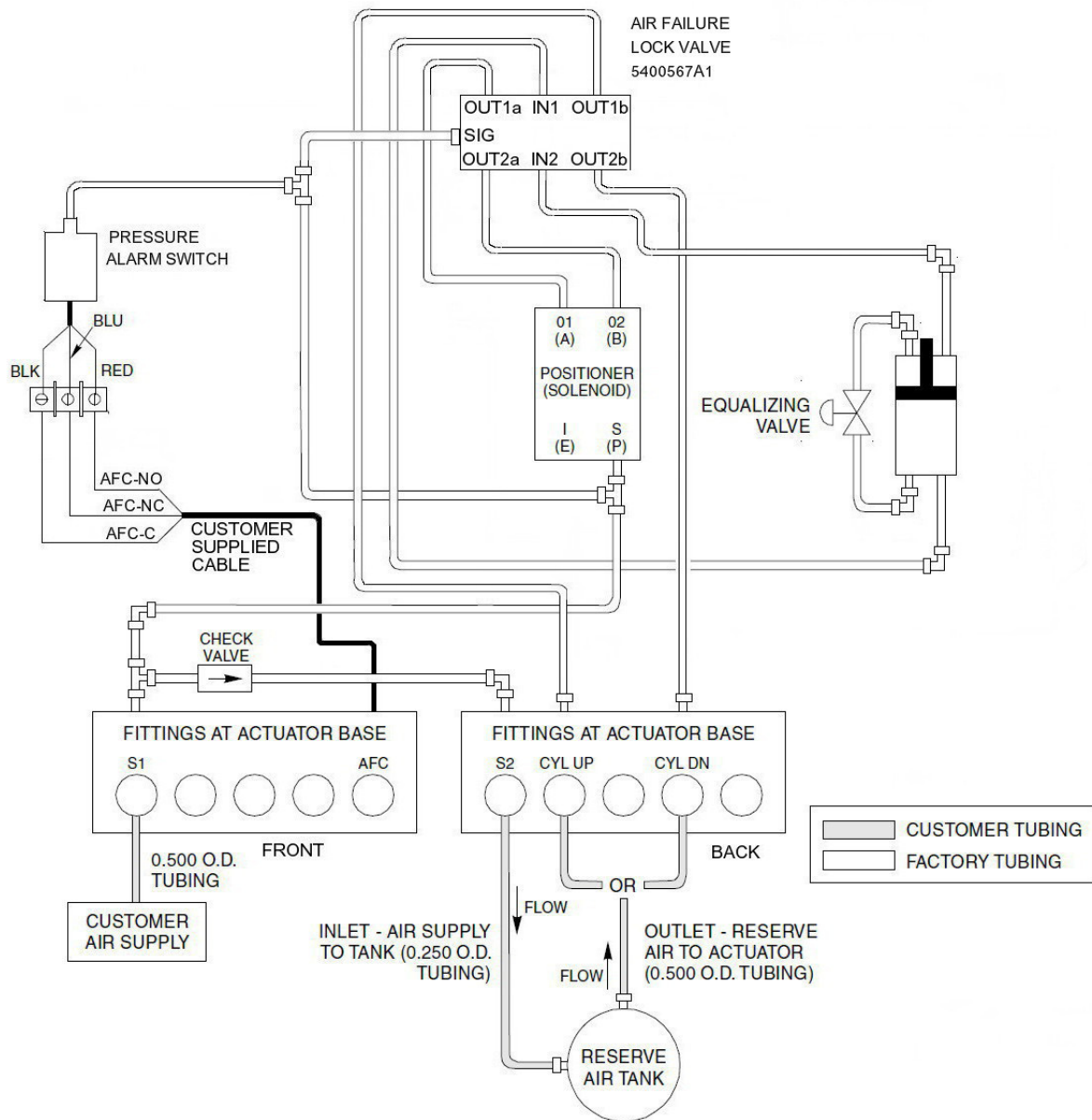

AIR FAILURE CONTROL = 4 FOR:  
 UP3, UP4, UP5, UP6, & UP7 (EXCEPT FOR UP5, UP6, & UP7 WITH TZID-C OR EDP300 POSITIONERS).

AIR FAILURE CONTROL = 4 MEANS RESERVE AIR TANK, ACTUATOR GOES TO 0 OR 100% (FIELD SELECTABLE)  
 UPON LOSS OF AIR SUPPLY, WITH PRESSURE SWITCH FOR AIR FAILURE ALARM.

TPSC2015UP\_15

Fig. 3.12: Reserve air tank tubing for Types UP3 to UP7 Actuators (with alarm pressure switch)

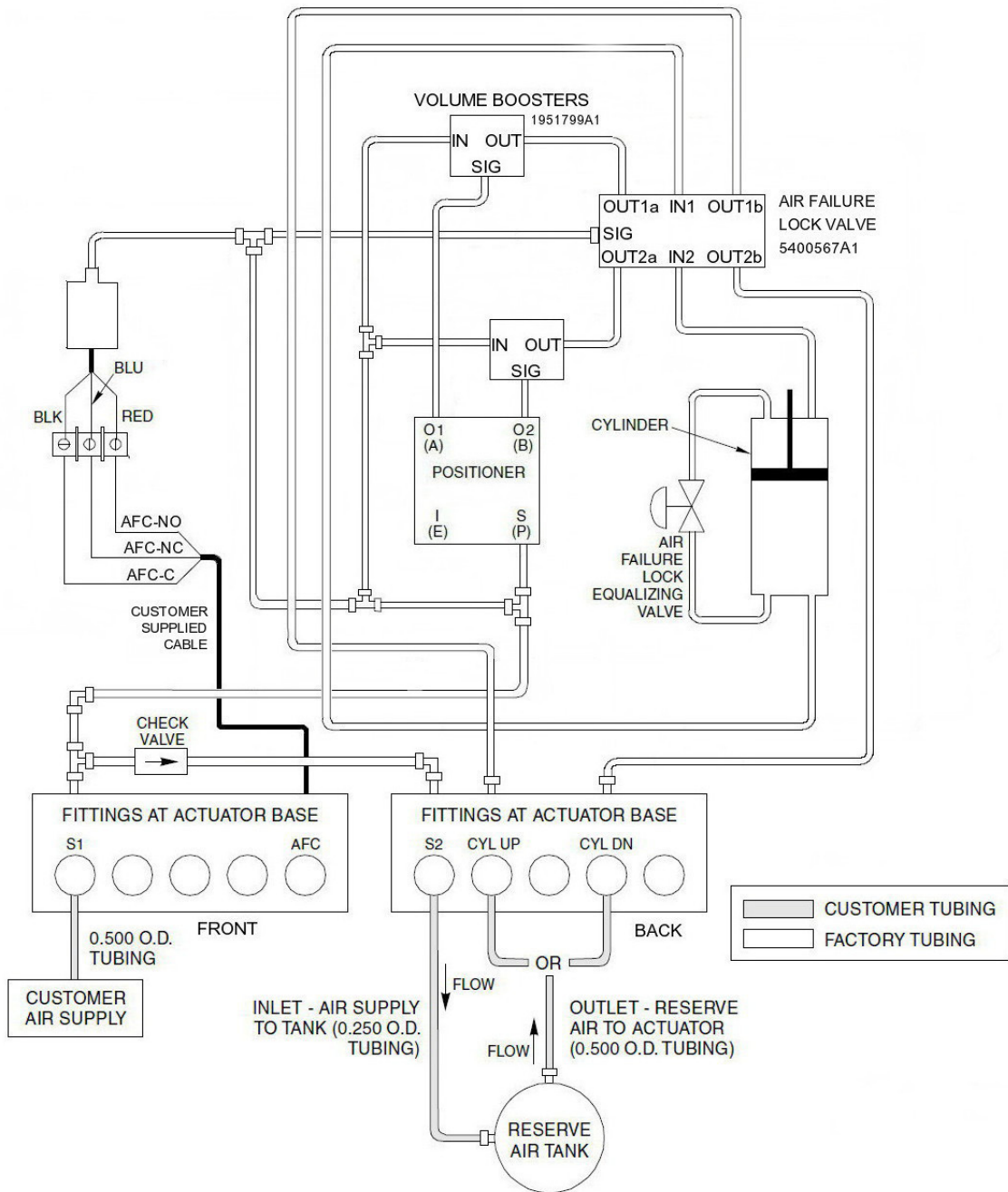

AIR FAILURE CONTROL = 4 FOR:  
 UP5, UP6, & UP7 WITH TZID-C OR EDP300 POSITIONERS

AIR FAILURE CONTROL = 4 MEANS RESERVE AIR TANK, ACTUATOR GOES TO 0 OR 100% (FIELD SELECTABLE)  
 UPON LOSS OF AIR SUPPLY, WITH PRESSURE SWITCH FOR AIR FAILURE ALARM.

TPSC2015UP\_16

Fig. 3.13: Reserve air tank tubing for Types UP3 to UP7 Actuators(with alarm pressure switch and volume boosters)

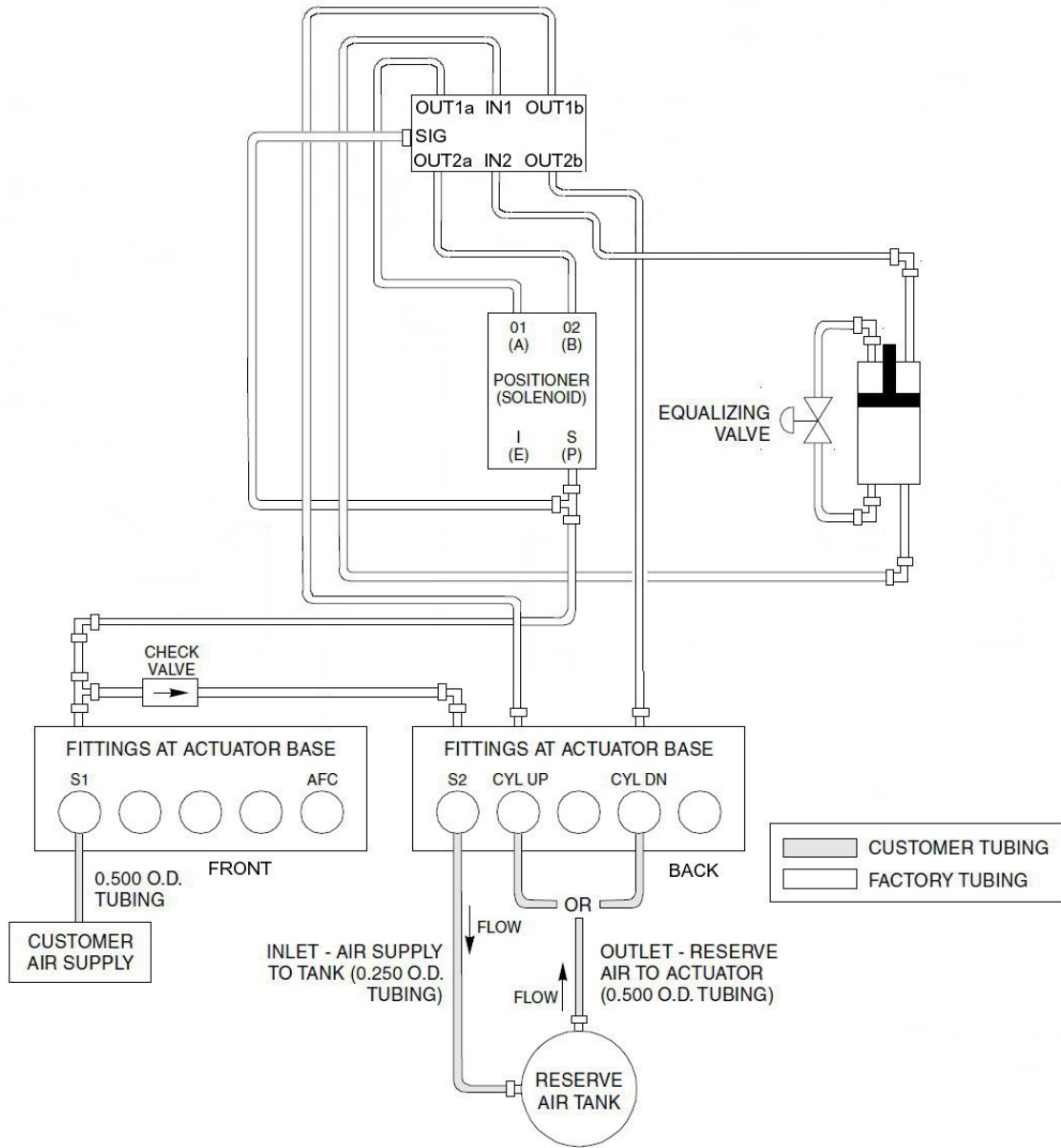

AIR FAILURE CONTROL = C FOR:

UP3, UP4, UP5, UP6, & UP7 (EXCEPT FOR UP5, UP6, & UP7 WITH TZID-C OR EDP300 POSITIONERS)

AIR FAILURE CONTROL = C MEANS RESERVE AIR TANK; ACTUATOR GOES 0 OR 100% (FIELD SELECTABLE) UPON LOSS OF AIR SUPPLY, WITHOUT PRESSURE SWITCH FOR AIR FAILURE ALARM.

TPSC2015UP\_17

Fig. 3.14: Reserve air tank tubing for Types UP3 to UP7 Actuators (without alarm pressure switch)

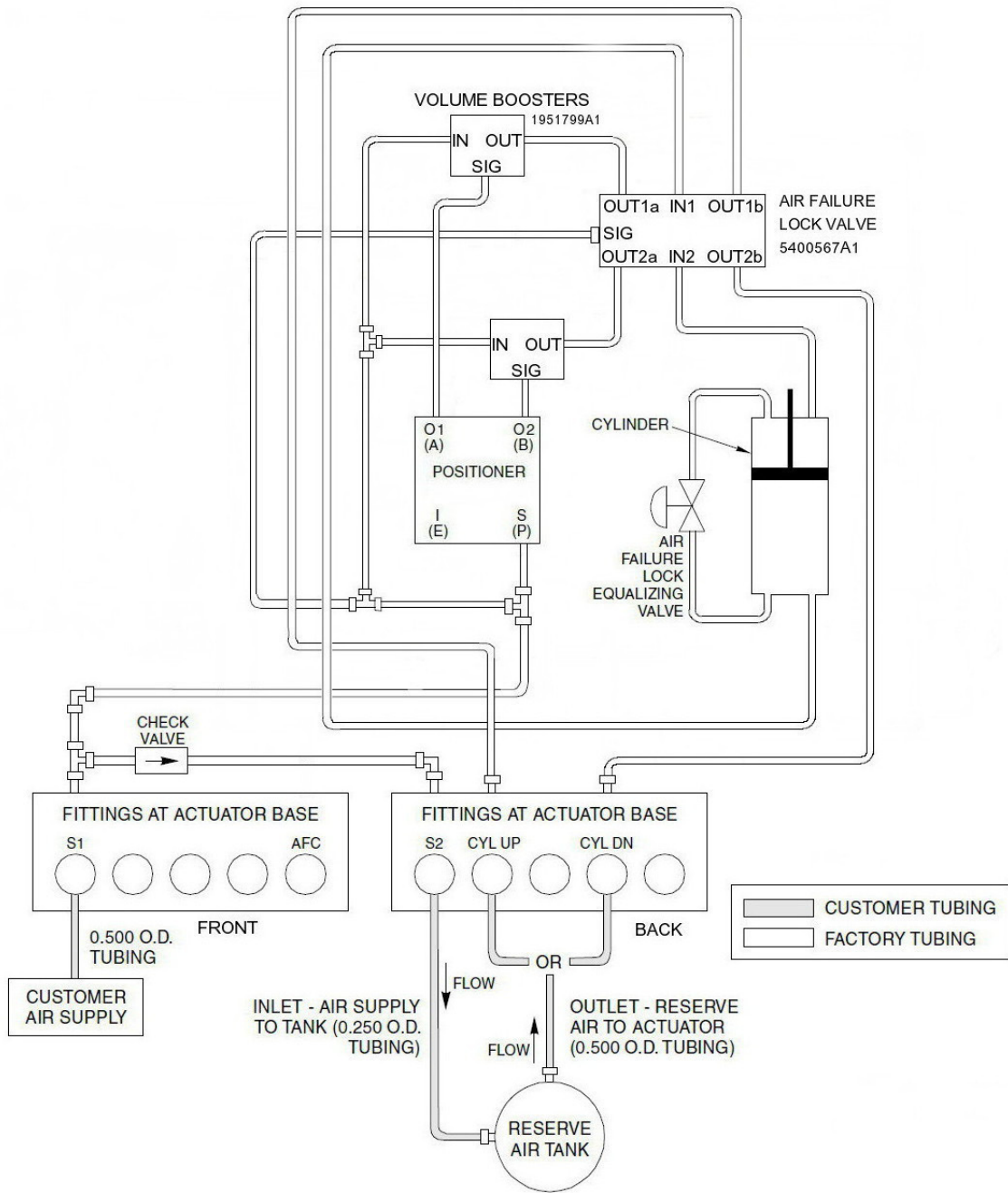

AIR FAILURE CONTROL = C FOR:  
 UP5, UP6, & UP7 WITH TZID-C OR EDP300 POSITIONERS

AIR FAILURE CONTROL = C MEANS RESERVE AIR TANK; ACTUATOR GOES 0 OR 100% (FIELD SELECTABLE)  
 UPON LOSS OF AIR SUPPLY, WITHOUT PRESSURE SWITCH FOR AIR FAILURE ALARM.

TPSC2015UP\_18

Fig. 3.15: Reserve air tank tubing for Types UP3 to UP7 Actuators (without alarm pressure switch, with volume boosters)

### 3.6.2 Air failure lock tubing

There are two possible tubing arrangements for actuators with the optional air failure lock.

**Automatic Reset.** The air failure lock automatically resets when the air supply exceeds the trip valve setting.

**Remote Reset.** The air failure lock remains tripped until deliberately reset via a reset switch as supplied (shown in Fig. 3.16) or a normally closed solenoid valve (not supplied).

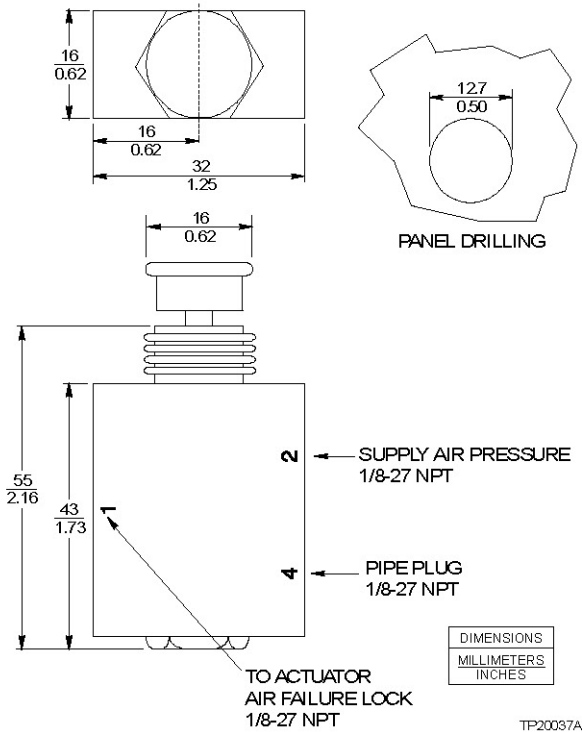

Fig. 3.16: Reset switch for air failure lock (drawing no. TP20037A)

### Type UP1 actuator

**Note.** The optional reset switch and pipe plug are located in a drawstring bag attached to the actuator frame.

Referring to Figs. 3.7, 3.16 and 3.18:

#### Automatic Reset

1. Connect the customer air supply directly to port OUT1 of the trip valve.
2. Connect the customer air supply also to port SIG on the trip valve.

#### Remote Reset

1. Connect the customer air supply directly to port OUT1 of the trip valve.
2. Install the reset switch in a suitable location. Refer to Fig. 3.16 for the dimensions.
3. Connect port 1 on the reset switch to port SIG on the trip valve.
4. Connect the customer air supply also to port 2 on the reset switch.
5. Install the pipe plug into port 4 of the reset switch.

#### Alarm Pressure Switch Installation

Referring to Figs. 3.7 and 3.18:

If required, connect a pressure switch (part number 1941099\_2 or equivalent) to sound an alarm or for status lights to indicate a loss of air supply.

1. Connect a tee between port 1 of the reset switch and port SIG of the trip valve.
2. Run tubing from the open end of the tee to the pressure switch.
3. Wire the switch to a terminal block or directly to the alarm as shown in Fig. 3.18.



## Type UP2 actuator

**Note.** The optional reset switch and pipe plug are located in a drawstring bag attached to the actuator frame.

Referring to Figs. 3.8, 3.16 and 3.19:

### Automatic Reset

1. Connect the customer air supply directly to the AF1 port on the actuator enclosure.
2. Connect the customer air supply also to the AF2 port on the actuator enclosure.

### Remote Reset

1. Install the pipe plug into port 4 of the reset switch.
2. Install the reset switch in a suitable location. Refer to Fig. 3.16 for the dimensions.
3. Install a tee into the air supply line.
4. Run tubing from one outlet of the tee to port 2 of the reset switch and from the other outlet of the tee to the AF1 port on the actuator frame.
5. Run tubing from port 1 of the reset switch to the AF2 port on the actuator frame.

### Alarm Pressure Switch Installation

Refer to Figs. 3.8 and 3.22.

If required, connect a pressure switch (part number 1941099\_2 or equivalent) to sound an alarm or for status lights to indicate a loss of air supply.

1. Connect a tee between port 1 of the reset switch and the AF2 port on the actuator frame.
2. Run tubing from the open end of the tee to the pressure switch.
3. Wire the switch to a terminal block or directly to the alarm as shown in Fig. 3.22.

## Types UP3 and UP4 actuators

**Note.** The optional reset switch and pipe plug are located in a drawstring bag attached to the actuator frame.

Referring to Figs. 3.5 and 3.21:

### Automatic Reset

1. Connect the customer air supply directly to the S1 port on the actuator enclosure.
2. Connect the customer air supply also to the AF1 port on the actuator enclosure.

### Remote Reset

1. Install the pipe plug into port 4 of the reset switch.
2. Install the reset switch in a suitable location. Refer to Fig. 3.16 for the dimensions.
3. Install a tee into the air supply line.
4. Run tubing from one outlet of the tee to port 2 of the reset switch and from the other outlet of the tee to the S1 port at the base of the actuator.
5. Run tubing from port 1 of the reset switch to the AF1 port at the base of the actuator.

### Alarm Pressure Switch Wiring

Types UP3 and UP4 actuators may come with an optional alarm pressure switch installed. If required, connect an alarm or status lights to indicate a loss of air supply.

Referring to Figs. 3.5 and 3.21:

1. Remove the side covers on both sides of the actuator as described in Section 3.4.
2. A conduit connection (AFC) is provided at the actuator base for access to the air failure contacts. Feed the wiring through this connection.
3. Make the connections to the proper points on the terminal strip as shown in Figs. 3.5 and 3.21.
4. Replace the side covers.

## Types UP5 UP6 and UP7 actuators

**Note.** The optional reset switch and pipe plug are located in a drawstring bag attached to the actuator frame.

Referring to Figs. 3.6, 3.21 or 3.22:

### Automatic Reset

1. Connect the customer air supply directly to the S1 port on the actuator enclosure.
2. Connect the customer air supply line to the AF1 port on the actuator enclosure.

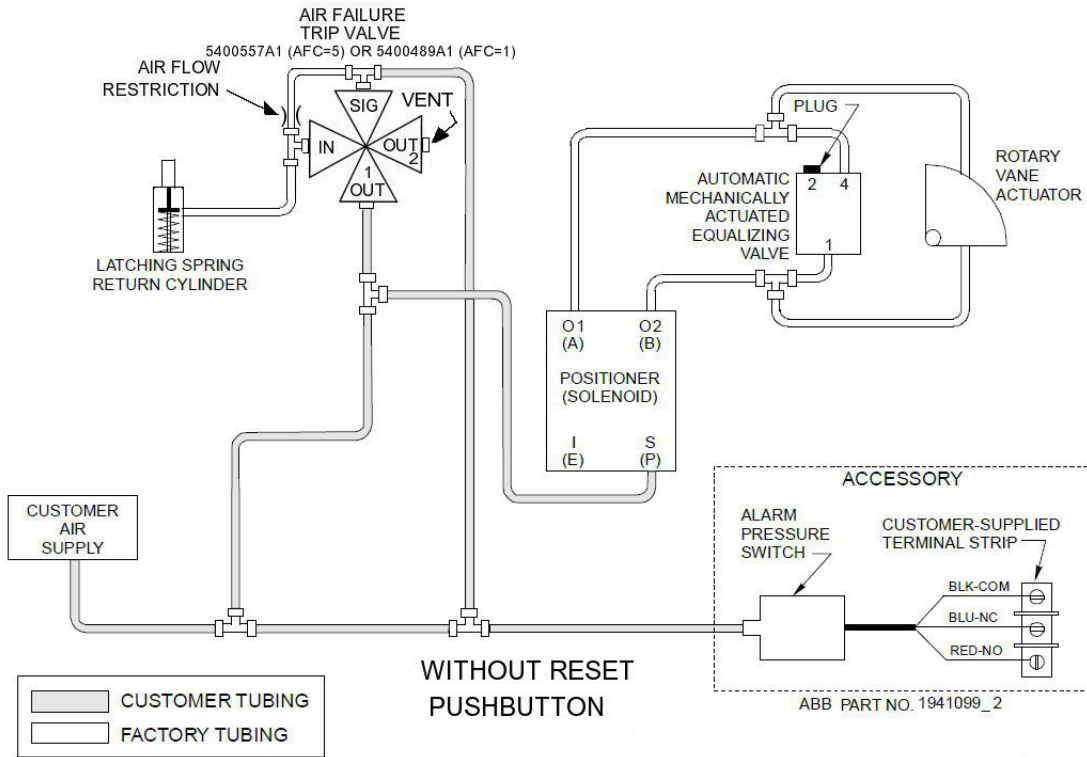
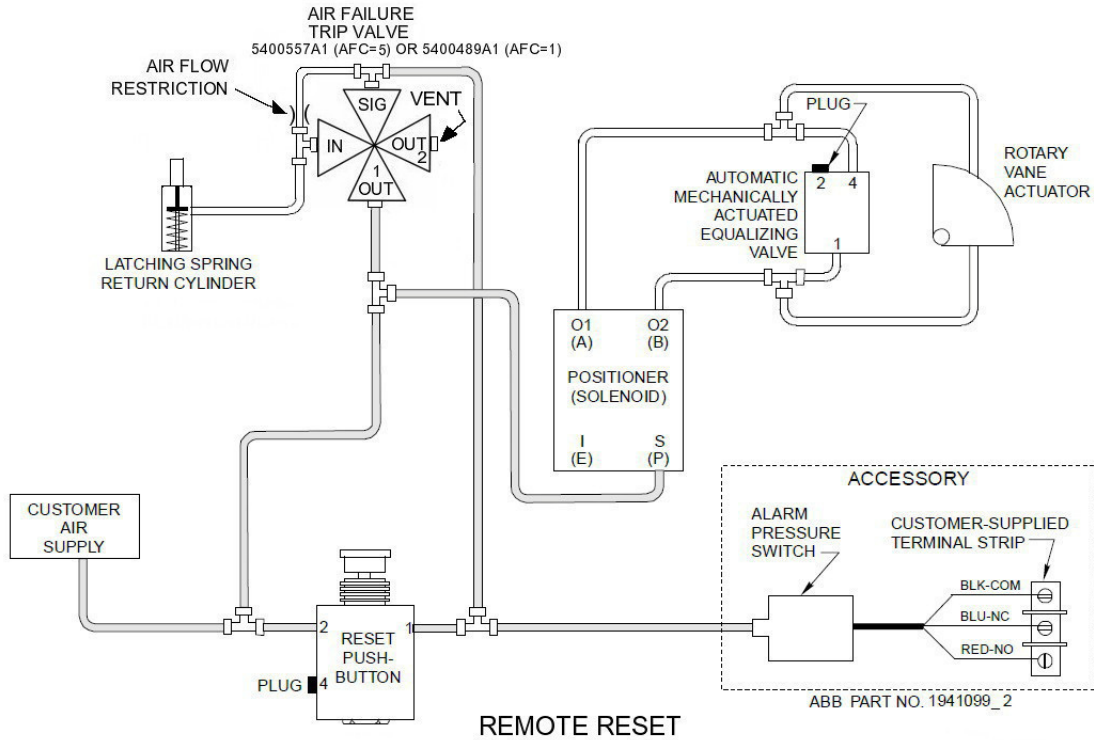

AIR FAILURE CONTROL = 1 OR 5 FOR UP1

AIR FAILURE CONTROL = '1' OR '5' MEANS AIR FAILURE LOCK UP (HOLD LAST POSITION) WITH MANUAL OR AUTOMATIC RESET FUNCTION AFTER AIR RECOVERY (INCLUDES REMOTE RESET SWITCH).

TPSC2015UP\_3

Fig. 3.17: Tubing schematic for type UP1 actuator with air failure lock

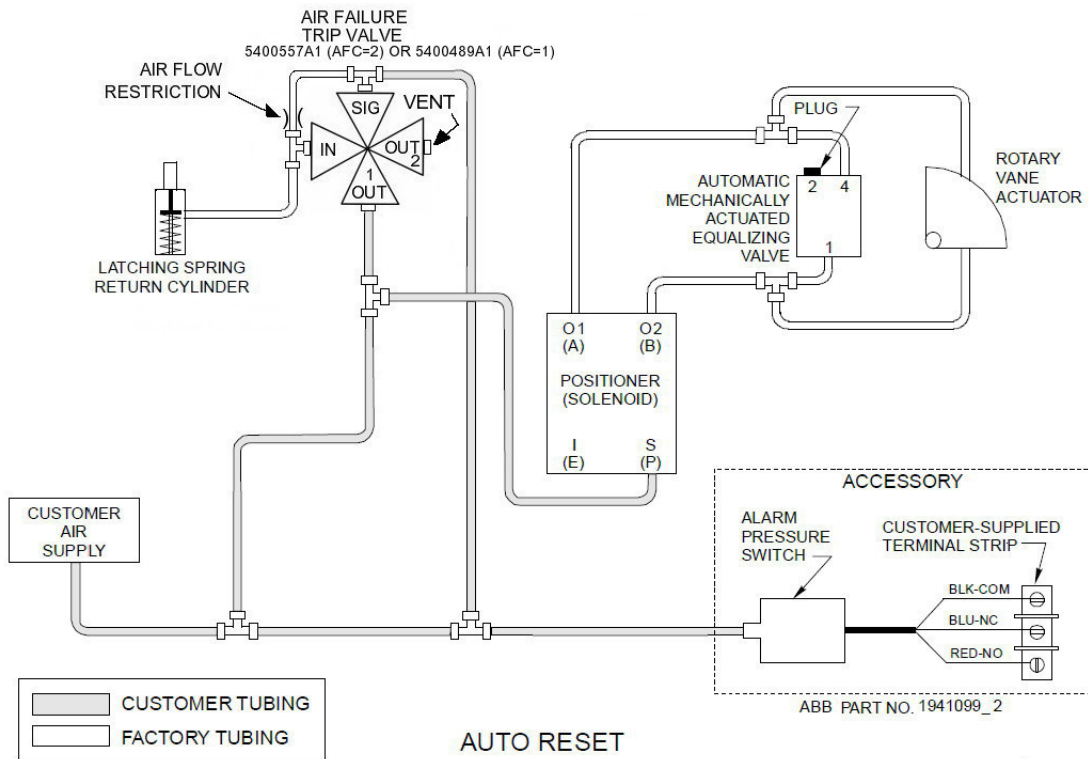

AIR FAILURE CONTROL = A OR D FOR UP1

AIR FAILURE CONTROL = 'A' OR 'D' MEANS AIR FAILURE LOCK UP (HOLD LAST POSITION) WITH AUTOMATIC RESET FUNCTION AFTER AIR RECOVERY.

TPSC2015UP\_4

Fig. 3.18: Tubing schematic for type UP1 actuator with air failure lock

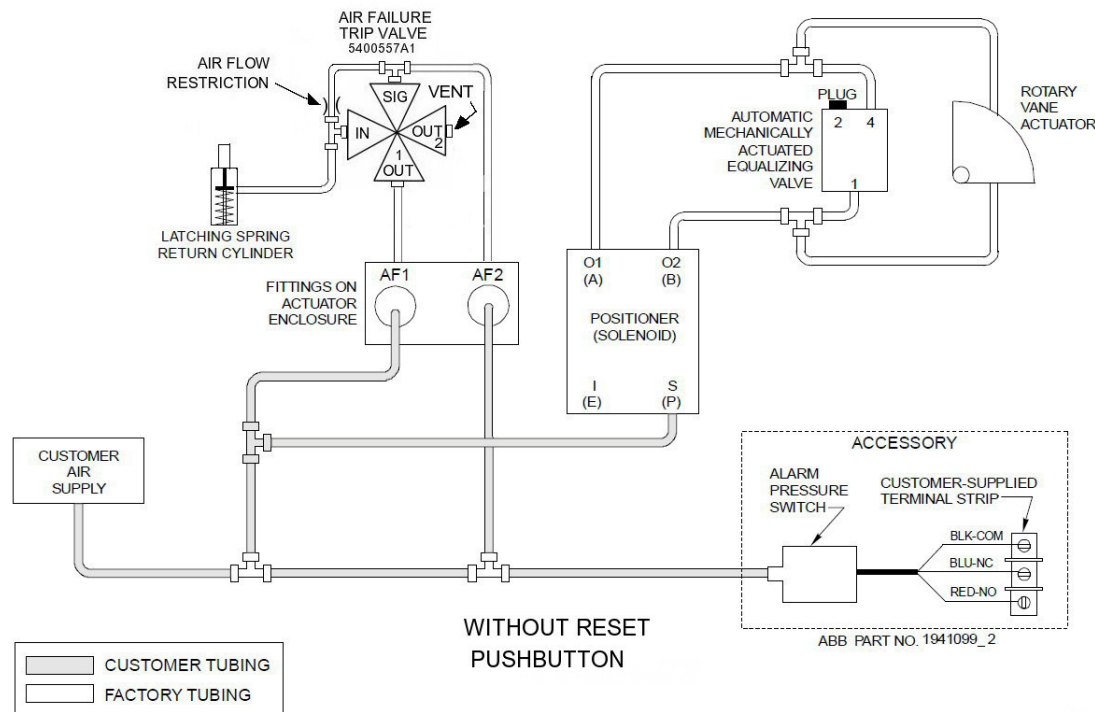
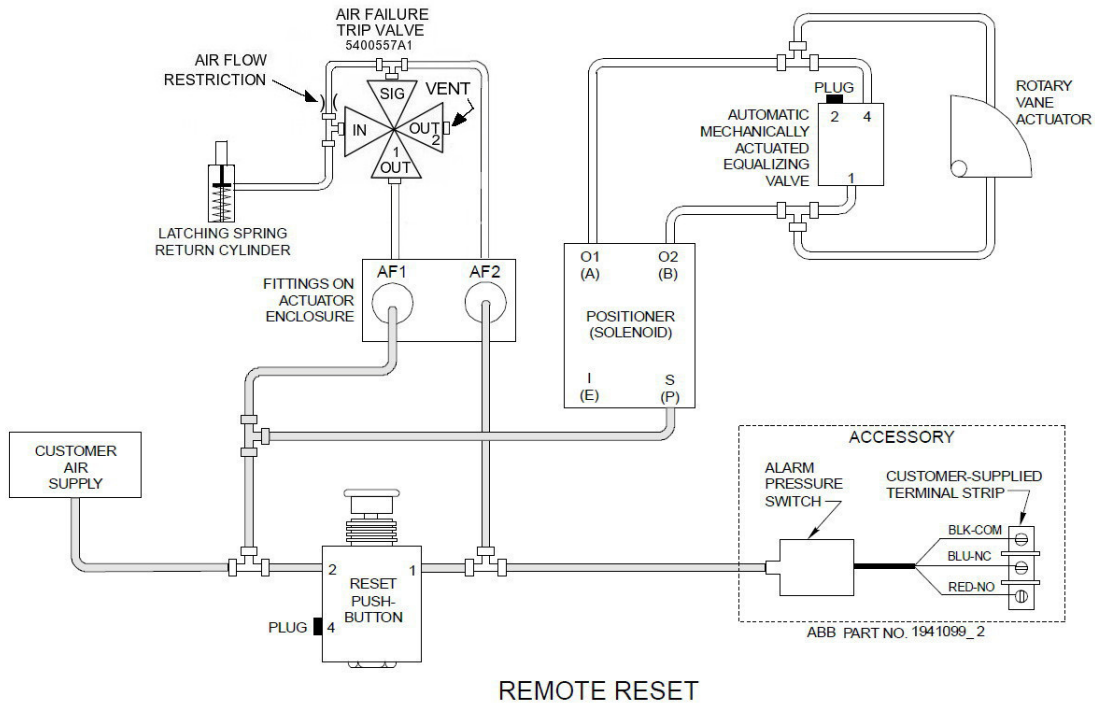

AIR FAILURE CONTROL = 1 FOR UP2

AIR FAILURE CONTROL = '1' MEANS AIR FAILURE LOCK UP (HOLD LAST POSITION) WITH MANUAL OR AUTOMATIC RESET FUNCTION AFTER AIR RECOVERY (INCLUDES REMOTE RESET SWITCH).

TPSC2015UP\_5

Fig. 3.19: Tubing schematic for Type UP2 actuator with air failure lock

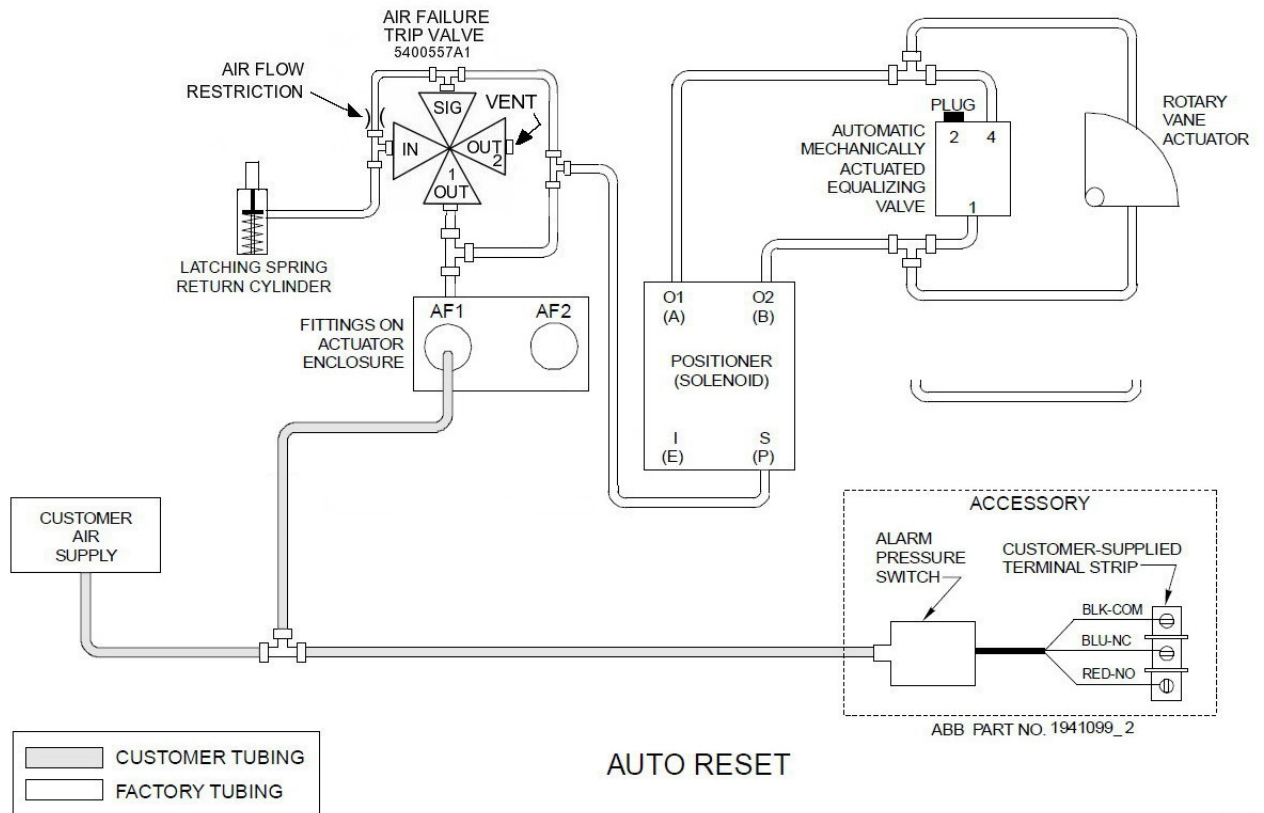

AIR FAILURE CONTROL = A FOR UP2

AIR FAILURE CONTROL = 'A' MEANS AIR FAILURE LOCK UP (HOLD LAST POSITION) WITH AUTOMATIC  
RESET FUNCTION AFTER AIR RECOVERY

TPSC2015UP\_6

Fig. 3.20: Tubing schematic for Type UP2 actuator with air failure lock

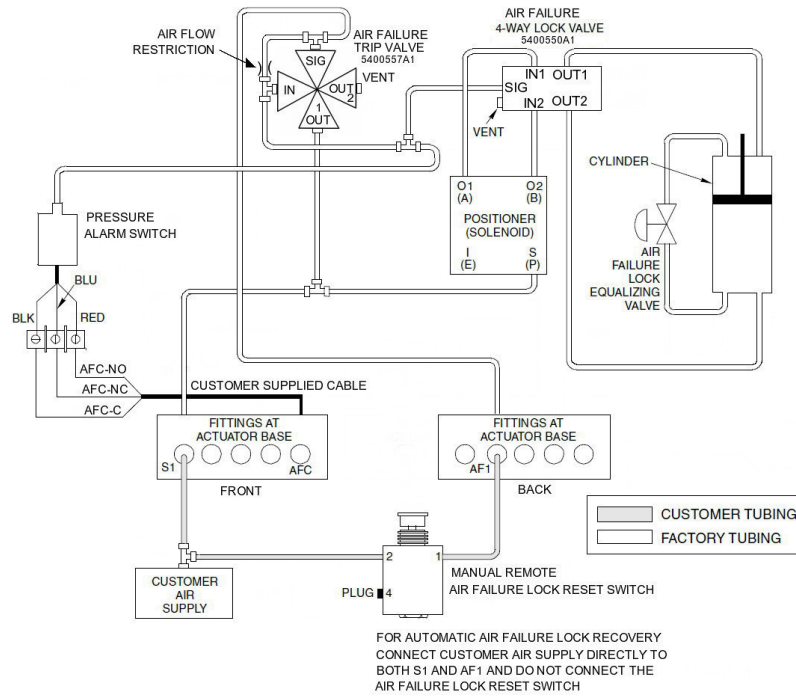

AIR FAILURE CONTROL = 1 FOR:  
UP3, UP4, UP5, UP6, & UP7 (EXCEPT FOR UP5, UP6, & UP7 WITH TZID-C OR EDP300 POSITIONERS)

AIR FAILURE CONTROL = 1 MEANS AIR FAILURE LOCK-UP (HOLD LAST POSITION UPON LOSS OF AIR SUPPLY) WITH MANUAL OR AUTOMATIC RESET FUNCTION AIR RECOVERY (INCLUDES REMOTE RESET SWITCH AND PRESSURE SWITCH).

TPSC2015UP\_11

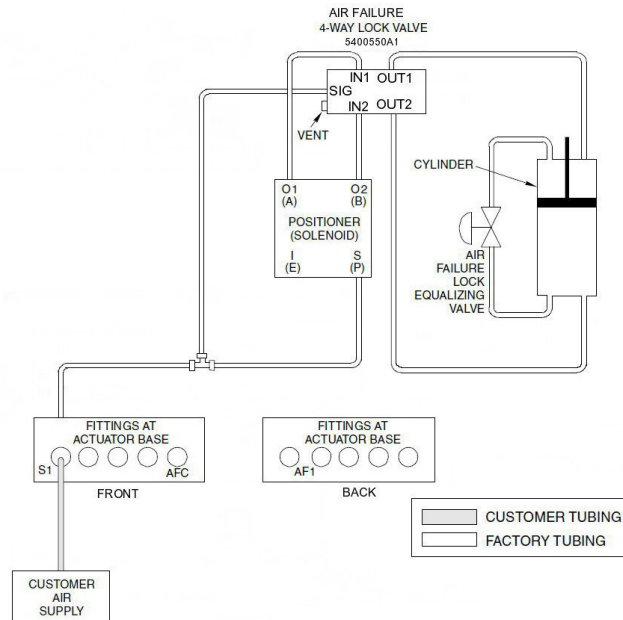

AIR FAILURE CONTROL = A FOR:  
UP3, UP4, UP5, UP6, & UP7 (EXCEPT FOR UP5, UP6, & UP7 WITH TZID-C OR EDP300 POSITIONERS)

AIR FAILURE CONTROL 'A' MEANS AIR FAILURE LOCK-UP (HOLD LAST POSITION UPON LOSS OF AIR SUPPLY) WITH AUTOMATIC RESET FUNCTION UPON AIR RECOVERY, WITHOUT PRESSURE SWITCH FOR AIR FAILURE ALARM.

TPSC2015UP\_13

Fig. 3.21: Tubing schematic for Types UP3 UP4, UP5, UP6 and UP7 actuators with air failure lock (except for UP5, UP6 and UP7 actuators with TZIDC or EDP300 positioners)

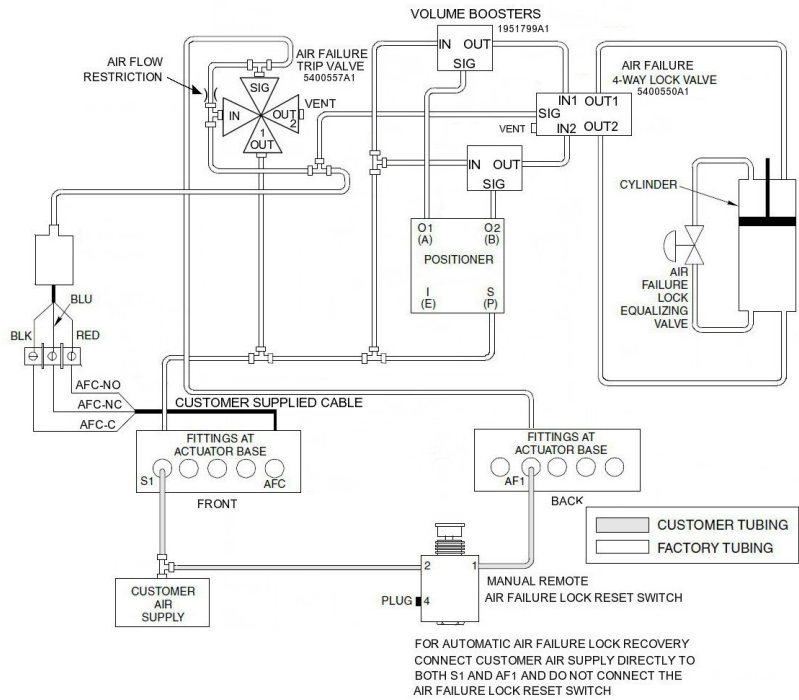

AIR FAILURE CONTROL = 1 FOR:  
 UP5, UP6, & UP7 WITH TZID-C OR EDP300 POSITIONERS

AIR FAILURE CONTROL = 1 MEANS AIR FAILURE LOCK-UP (HOLD LAST POSITION UPON LOSS OF AIR SUPPLY) WITH MANUAL OR AUTOMATIC RESET FUNCTION AIR RECOVERY (INCLUDES REMOTE RESET SWITCH AND PRESSURE SWITCH).

TPSC2015UP\_12

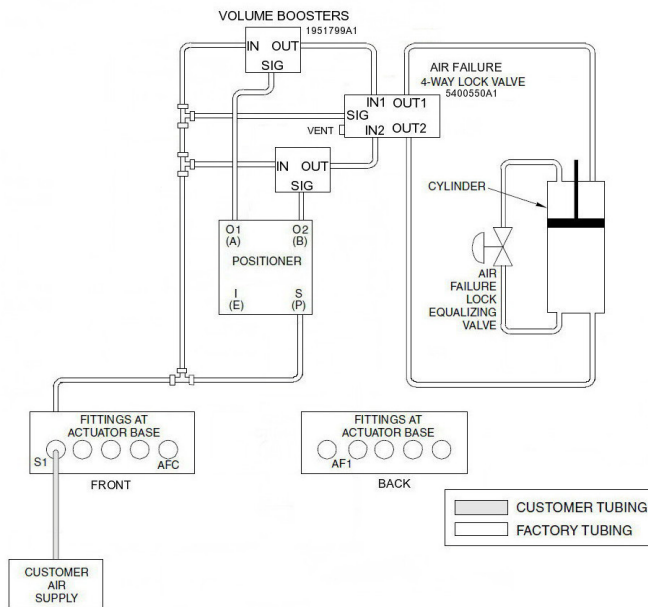

AIR FAILURE CONTROL = A FOR:  
 UP5, UP6, & UP7 WITH TZID-C OR EDP300 POSITIONERS

AIR FAILURE CONTROL 'A' MEANS AIR FAILURE LOCK-UP (HOLD LAST POSITION UPON LOSS OF AIR SUPPLY) WITH AUTOMATIC RESET FUNCTION UPON AIR RECOVERY, WITHOUT PRESSURE SWITCH FOR AIR FAILURE ALARM.

TPSC2015UP\_14

Fig. 3.22: Tubing schematic for Types UP5, UP6 and UP7 actuators with air failure lock and TZIDC or EDP300 positioners

### 3.6.3 Pneumatic shaft position transmitter tubing for Types UP2 to UP7 actuators

**Note.** A pneumatic shaft position transmitter is not available for the Type UP1 actuator.

#### Types UP2, UP3 and UP4 actuators

These actuators have the pneumatic shaft position transmitter mounted externally.

Referring to Figs. 3.4 and 3.5:

1. Connect the required air supply line directly to the S port of the shaft position transmitter.
2. Using ¼ in. tubing and suitable fittings, connect the output line to the street tee in the O2 port of the shaft position transmitter.
3. Maintain a supply pressure of at least 35 kPa (5 psig) above the maximum required output pressure, but not higher than 345 kPa (50 psig).

#### Types UP5, UP6 and UP7 actuators

These actuators have the pneumatic shaft position transmitter mounted internally.

Referring to Fig. 3.6:

1. Connect the required air supply directly to the S2 port at the base of the actuator.
2. Connect the output line directly to the E2 port at the base of the actuator.
3. Use ¼ in. tubing and suitable fittings.
4. Maintain a supply pressure of at least 35 kPa (5 psig) above the maximum required output pressure, but not higher than 345 kPa (50 psig).

### 3.6.4 Volume booster tubing for Type UP6 and UP7 actuators

All tubing connections inside the Type UP6 actuator for the optional volume booster are completed before despatch. External tubing is the same as that for Type UP6 and UP7 actuators described in this chapter, except the S1, S2 and S3 bulkhead connections on the actuator are ¾-14 NPT. Customer tubing must be one inch OD tubing or ¾-14 NPT schedule 40 pipe.

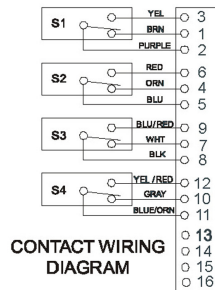
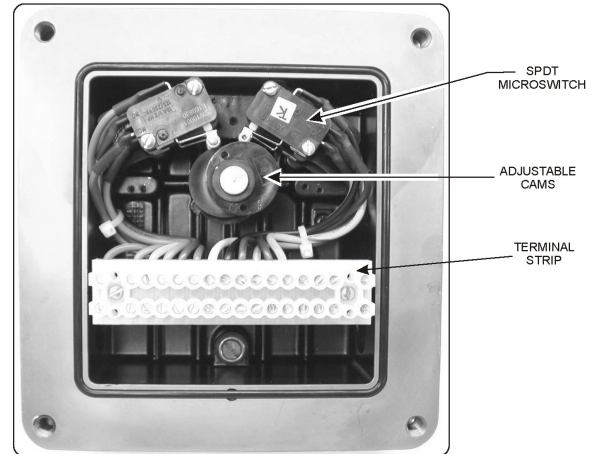

NOTE: SWITCH CONTACTS MUST BE DERATED 1.5 A FOR EVERY 10°C (18°F) RISE ABOVE 60°C (140°F).

TP20119C\_1

Fig. 3.23: Alarm / Travel switches UP actuator (drawing no. TP20119C\_1)



### 3.6.5 Alarm /Travel switch contact wiring for Types UP1 to UP7 Actuators

If the actuator comes with alarm / travel switches. These switches can be used as alarm contacts or for an external indication and has to be adjusted in the fieldbus required.

Refer to Fig. 3.23.

#### Types UP1 and UP2 actuators

The adjustable travel switches for UP1 and UP2 actuators are located inside the cover of the limit switch assembly mounted to actuator frame.

Referring to Figs. 3.1, 3.4 and 3.23:

1. Remove the 4 screws retaining the cover of the limit switch assembly.
2. Run the wires through the conduit connector, make the electrical connections to the switches at the terminal block as shown in Figs. 3.1 and 3.23 and replace the cover, of the limit switch assembly.

#### Types UP3 and UP4 actuators

Referring to Fig. 3.5:

1. Remove the side cover on the cylinder side of the actuator as described in Section 3.4.
2. Make the electrical connections from the switches at the terminal block located on the actuator frame as shown in Fig. 3.5.
3. Run the wires through conduit connector V2 at the base of the actuator.
4. Replace the side cover.

#### Types UP5, UP6 and UP7 actuators

Referring to Fig. 3.6:

1. Remove the bottom side cover and top side cover on the cylinder side of the actuator as described in Section 3.4.
2. Make the electrical connections from the switches at the terminal block located on the actuator frame as shown in Fig. 3.6.
3. Run the wires through conduit connector V1 at the base of the actuator.
4. Replace the actuator covers.

### 3.6.6 Shaft position transmitter wiring for Types UP1 and UP2 Actuators

The position transmitter is located within the AV or TZIDC positioner if a shaft position transmitter is designated in the UP nomenclature.

Wiring for the shaft position transmitter is terminated directly at the AV or TZIDC positioner. Refer to AV or TZIDC Instruction manuals for wiring details (see Appendix A.1).

#### Types UP3 to UP7 actuators

Refer to Fig. 3.5 for UP3/4

Refer to Fig. 3.6 for UP5/6/7

The position transmitter is located within the AV or TZIDC positioner if a Shaft Position Transmitter is designated in the UP nomenclature. The AV, TZIDC or EDP300 positioner is located inside the UP enclosure.

A conduit connection (V1) is provided at the actuator base for signal wiring to the shaft position transmitter.

#### Wiring for the shaft position transmitter is terminated at the actuator base terminal block.



#### NOTICE – Property damage

Signal wiring connected in this box must be rated for at least 300 V. Failure to use the correct wire may cause a short circuit and / or a fire that would damage the equipment and affect the process.

---

The transmitter, a 2-wire, 4 to 20 mA output device, operates on 12 to 30 V DC. The signal wiring supplies power to the transmitter. Refer to Fig. 3.24 for a typical wiring loop diagram. Use wire with a cross-sectional area of 0.32 to 2.10 mm<sup>2</sup> (22 to 14 AWG) rated at a minimum of 300 volts.

A twisted pair or shielded wire reduces the chance of noise pickup. If needed, ground the signal wiring at any location in the loop, but not at more than one point. If there are several transmitters on a single power supply, make the ground connection at the power supply.

Do not run wiring near high power electrical equipment or in the same conduit or trays as the power wiring. Although power supply regulation is not vital, ripple should not exceed 0.5 V peak-to-peak; this ensures a stable output signal. Supply voltages and load changes during operation have no effect on accuracy. Do not exceed the maximum of the combined resistance of the load and the signal wiring, as applicable to the shaft position transmitter.

Refer to the AV, TZIDC or EDP300 Instruction manuals for more detail on the position transmitters.

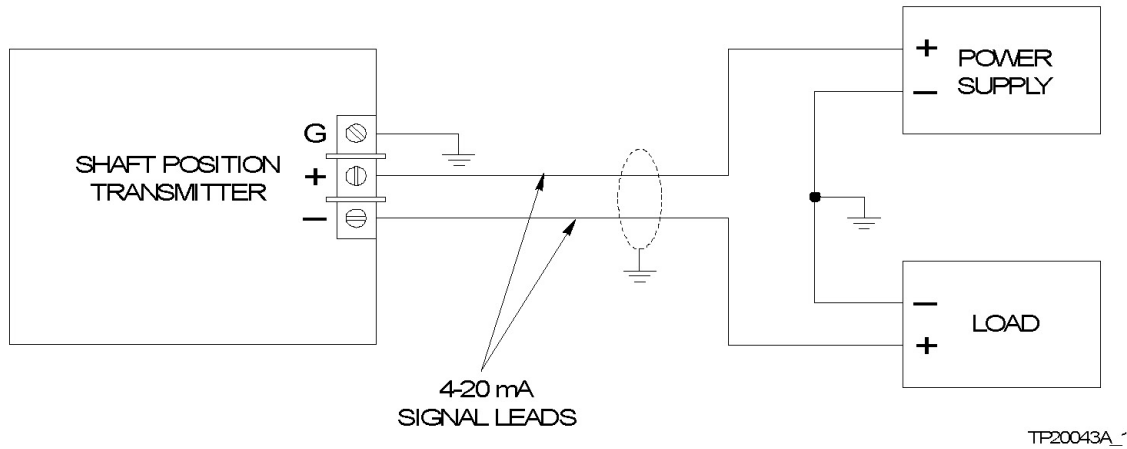

Fig. 3.24: Typical wiring loop diagram for the shaft position transmitter (drawing no. TP20043A\_1)

### 3.6.7 Strip heater wiring for Types UP2 to UP7 actuators



**WARNING – Bodily injury**  
Potential electrical hazard.

**Note.** Strip heaters are not available for Type UP1 actuators.

ABB recommends ordering actuators with heating elements installed for applications where the ambient temperature remains below 0 °C (32 °F) for extended periods. A thermostick automatically starts the heaters when the temperature drops below approximately 4 °C (40 °F).

**Note.** Follow the procedures for gaining access to the terminal strips for the alarm / travel switches in Section 3.6.5 for Types UP1 through UP7 Actuators.

#### Type UP2 actuator

Referring to Fig. 3.4:

1. Make the connections to the terminal strip L1 (hot) and L2 (neutral).
2. Run the wires through the conduit opening in the actuator frame.
3. Replace the actuator covers.

#### Types UP3 and UP4 actuators

Referring to Fig. 3.5:

1. Make the connections to the terminal strip L1 (hot) and N (neutral).
2. Run the wires through the HTR conduit opening in the actuator frame.
3. Replace the actuator covers.

#### Types UP5, UP6 and UP7 actuators

Referring to Fig. 3.6:

1. Make the connections to the terminal strip L1 (hot) and N (neutral).
2. Run the wires through the HTR conduit opening in the actuator frame.
3. Replace the actuator covers.

### 3.7 Pre-operating adjustments

Use these procedures to make adjustments necessary to make the actuator operational.

#### 3.7.1 Control loading arrangements

The actuator is usually supplied with the tubing connections made for direct loading operation. If required, change to reverse loading operation.

#### Positioner control loading arrangements

The two types of positioner control loading are direct loading and reverse loading. Direct loading allows movement from 0 to 100 % (position indicator reading) as the control signal to the positioner increases. The actuator is supplied from the factory in this configuration.

Reverse loading allows the actuator to move from 100 to 0 % as the control signal to the positioner increases. To change from direct loading to reverse loading, remove the actuator covers (if required) necessary to access the positioner as outlined in Section 3.4 Enclosure removal. Follow the instructions for reverse loading in the appropriate positioner manual (see Appendix A.1).

#### Solenoid valve control loading arrangements



#### WARNING – Bodily injury

Potential electrical hazard.

---

The actuator is usually supplied with the tubing connections made for direct loading operation. If required, change to reverse loading operation.

Direct loading allows movement from 0 to 100 % when the solenoid is energized. The actuators are supplied from the factory in this configuration.

Reverse loading allows movement from 100 to 0 % when the solenoid is energized. To switch from direct to reverse loading:

1. Remove the actuator covers (if required) to gain access to the solenoid valve as described in Section 3.4 Enclosure removal.
2. Loosen the air line connections at the A and B ports of the solenoid.
3. Reverse the air line connections and tighten these connections.

**Note.** For dual coil solenoid valves, reverse either the air lines or the electrical connections to the coils.

4. Replace the actuator covers.

### 3.7.2 Operating lever adjustment



#### WARNING – Bodily injury

Failure to tighten the lever assembly bolts to the torque specifications may cause the load to shift and bodily injury could result.

---

#### Type UP1 actuator

1. Loosen the 2 socket hex-head cap screws in the lever hub using a ½-in. socket wrench.
2. Determine at what angle to locate the lever for 0 % position (normally parallel to the driven lever).
3. Rotate the lever to the correct position.
4. Secure the lever assembly to the shaft by tightening the socket hex-head cap screws to 71 to 79 Nm (52 to 57 ft/lb).
5. Connect the linkage to the lever in the required arrangement.
6. Refer to Connecting Linkage (G81-5-1C) for universal rotary actuators for alternate linkage arrangements.

#### Type UP2 actuator

1. Loosen the 2 socket hex-head cap screws in the lever hub using a ½ in. hex wrench.
2. Determine at what angle to locate the lever for 0 % position (normally parallel to the driven lever).
3. Rotate the lever to the correct position.
4. Secure the lever assembly to the shaft by tightening the socket hex-head cap screws to 85 to 91 Nm (63 to 67 ft/lb).
5. Connect the linkage to the lever in the required arrangement.
6. Refer to Connecting Linkage for universal rotary actuators for alternate linkage arrangements – refer to Appendix 4 on page 13.

### Types UP3/4/5/6/7 actuators

1. Loosen the clamping screws in the lever hub.
2. Pull the lever off of the splined shaft.
3. Determine at what angle to locate the lever for 0 % position (normally parallel to the driven lever).

**Note.** The lever may be located on either end of the shaft.

4. Push the lever onto the shaft in the required position.
5. Secure the lever to the shaft by tightening the clamping screws to 38 to 44 Nm (28 to 32 ft/lb).
6. Connect the linkage to the lever in the required arrangement.
7. Refer to Connecting Linkage for universal rotary actuators for alternate linkage arrangements – refer to Appendix 4 on page 41.

### 3.7.3 Position indicator

When changing the control loading of the actuator, switch the scale for the position indicator to match the rotation of the actuator.

**Note.** Before mounting the position indicator, clean dust, dirt, oil, moisture, etc. from the mounting surface.

### Types UP1 and UP2 actuators

Types UP1 and UP2 actuators come with 2 adhesive-backed position indicator scales. They are graduated from 0 to 100 % in 10 % increments. One scale, fixed to the sector plate at the factory, reads 0 to 100 % from left to right. The second scale, taped to the rear side of the sector plate, reads 0 to 100 % from right to left. Install the latter scale on reverse acting actuators to match the rotation of the driven device. Simply remove the backing and place the reverse indicating scale over the scale installed at the factory.

### Types UP3/4/5/6/7 actuators

Types UP3, UP4, UP5, UP6 and UP7 actuators come with a shaft mounted position indicator and indicator scales graduated from 0 to 100 % in 25 % increments. One scale reads 0 to 100 % from right to left. The second scale reads 0 to 100 % from left to right. These scales come in a separate bag. Choose the scale that matches the closed versus open position of the driven device. Two punch marks on the actuator at the output shaft help position the scale.

### 3.7.4 Mechanical stop adjustment for Types UP1 and UP2 actuators

**Note.** The mechanical stop is available only on the types UP1 and UP2 actuators.

The nominal setting of the stroke is for a rotation of 90 °. Adjustable mechanical stops, located on each end of the actuator, allow adjustment over a range of 80 to 92 °.

Referring to Figs. 3.1 and 3.4:

1. Loosen the 5/16-18 hex nut located on the socket head stops crew.
2. Hold the hex nut and adjust the stops crew clockwise to decrease the rotation, or counter clockwise to increase rotation.
3. Tighten the hex nut.
4. Calibrate the positioner (if supplied) for the new output stroke.

## Appendix A – Documents

### A.1 Other applicable documents – see Note 1

- Data sheet UP series actuators (DS/A/UP-EN)
- Service manual UP series actuators (OI/UP)
- Data sheet AV series positioners (DS/AV1234-EN)
- Operating instructions AV1/2 positioners (OI/AV12)
- Operating instructions AV3/4 positioners (OI/AV34) – see Note 2
- Data Sheet TZIDC intelligent positioner (10/18-0.22-EN)
- Operating instructions TZIDC, TZIDC-110, TZIDC-120 positioner (42/18-84-EN)
- Configuration / Parameterization instructions for TZIDC, TZIDC-1x0, TZIDC-2x0 positioner (45/18-79-EN)
- Data sheet EDP300 Intelligent Positioner (DS/EDP300-EN)
- Operating Instructions EDP300 (OI/EDP300- EN)
- Connecting linkage for universal rotary actuators (G81-5-1C)

**Note 1.** *UP pneumatic drawings under Warminster SD-50-2785.*

**Note 2.** *Effective 1 Jan 2016, the AV3 positioner option is no longer available.*

### A.2 Approval and certificates

CE mark

The version of the device as provided by us meets the requirements of the following EU directives:

- Machinery directive 2006/42/EC
- Low Voltage directive 2006/95/EC



## EC Declarations UP Series of Pneumatic Actuators

ABB Inc  
125 County Line Road  
Warminster, PA 18974 USA

### EC Declaration of Conformity:

The ABB UP1, UP2, UP3, UP4, UP5, UP6, and UP7 pneumatic actuators are in compliance with the herein listed council directives of the European Community and are marked with the CE marking. The safety and installation requirements contained in the product documentation must be adhered to.

#### Pressure Equipment Directive, PED, 97/23/EC

- All UP pneumatic actuators are limited to instrument quality air, Gas Group 2, and are excluded from the requirements of the PED based on:
  - Article 1, paragraph 3.6, the first indent related to machinery
- UP1, UP2, UP3, UP4, UP5, UP6, and UP7 pneumatic actuator sizes adhere to Sound Engineering Practice described in Article 3, paragraph 3.

#### Low Voltage Directive, 2006/95/EC

- UP1, UP2, UP3, UP4, UP5, UP6, and UP7 pneumatic actuator contain electrical control and monitoring accessories. These electrical devices and their incorporation within the UP Series of pneumatic actuators have been evaluated and proven to be in complete adherence to the following standard:
  - EN 50178:1997

### EC Declaration of Incorporation:

The ABB UP1, UP2, UP3, UP4, UP5, UP6, and UP7 pneumatic actuators are in compliance with the herein listed council directives of the European Community and are marked with the CE marking. The safety and installation requirements contained in the product documentation must be adhered to.

#### Machinery Directive, 2006/42/EC, Appendix IIb, partly completed machinery with the following listed essential requirements applied and complied with:

- 1.1.2, 1.1.3, 1.1.5, 1.3.2, 1.3.4, 1.3.7, 1.5.3, 1.5.4, 1.5.7, 1.6.1, 1.7.1, 1.7.3, and 1.7.4 .
- Technical documentation is prepared and completed in compliance with Appendix VII, section B .
- Before the UP actuator is placed into operation, the machine into or onto which the UP actuator will be installed, must comply with the requirements of the machinery directive.
- Applicable standards:
  - ISO 12100:2010, ISO 4414:2010

Name : David Madden  
Position : Quality & Certifications  
Date : 03-Sep-2013  
Location : Warminster, PA USA

Name : Stan Chlebda  
Position : Product Development  
Date : 03-Sep-2013  
Location : Warminster, PA USA

Signature : 

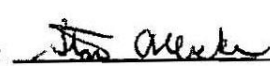
Signature : 

# Appendix C – Dimension drawings

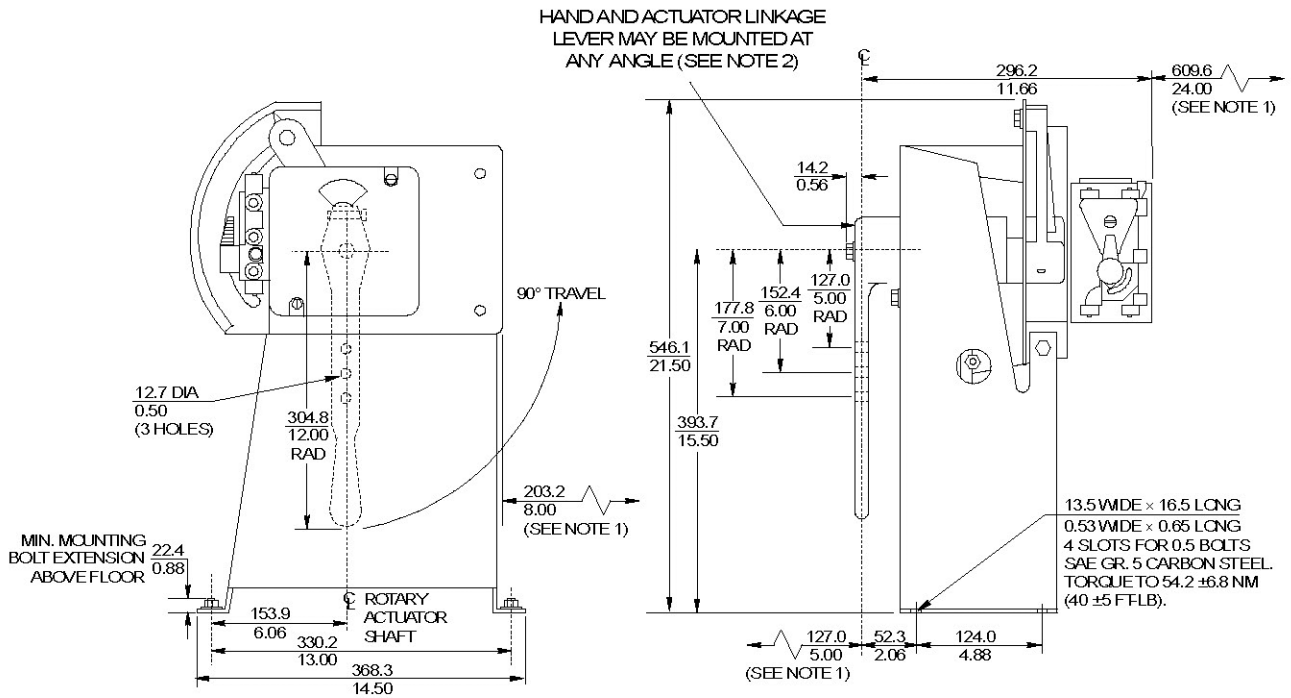

**NOTES:**

1. MINIMUM CLEARANCE FOR ADJUSTMENT, INSPECTION, MAINTENANCE AND OPERATION REQUIRED.
2. AFTER POSITIONING ACTUATOR LEVER, TORQUE TWO 0.375 IN. SOCKET HEAD CAP SCREWS TO 74.6 ± 2.7 NM (55 ± 2 FT-LB).
3. MAXIMUM AMBIENT TEMPERATURE LIMIT = 82°C (180°F). SOME ACTUATOR/POSITIONER COMBINATIONS MAY HAVE A SLIGHTLY LOWER MAXIMUM AMBIENT TEMPERATURE LIMIT. REFER TO THE APPROPRIATE POSITIONER SPECIFICATION.

TP20114B

Fig. C.1: Type UP1 actuator with positioner (drawing no. TP200114B)

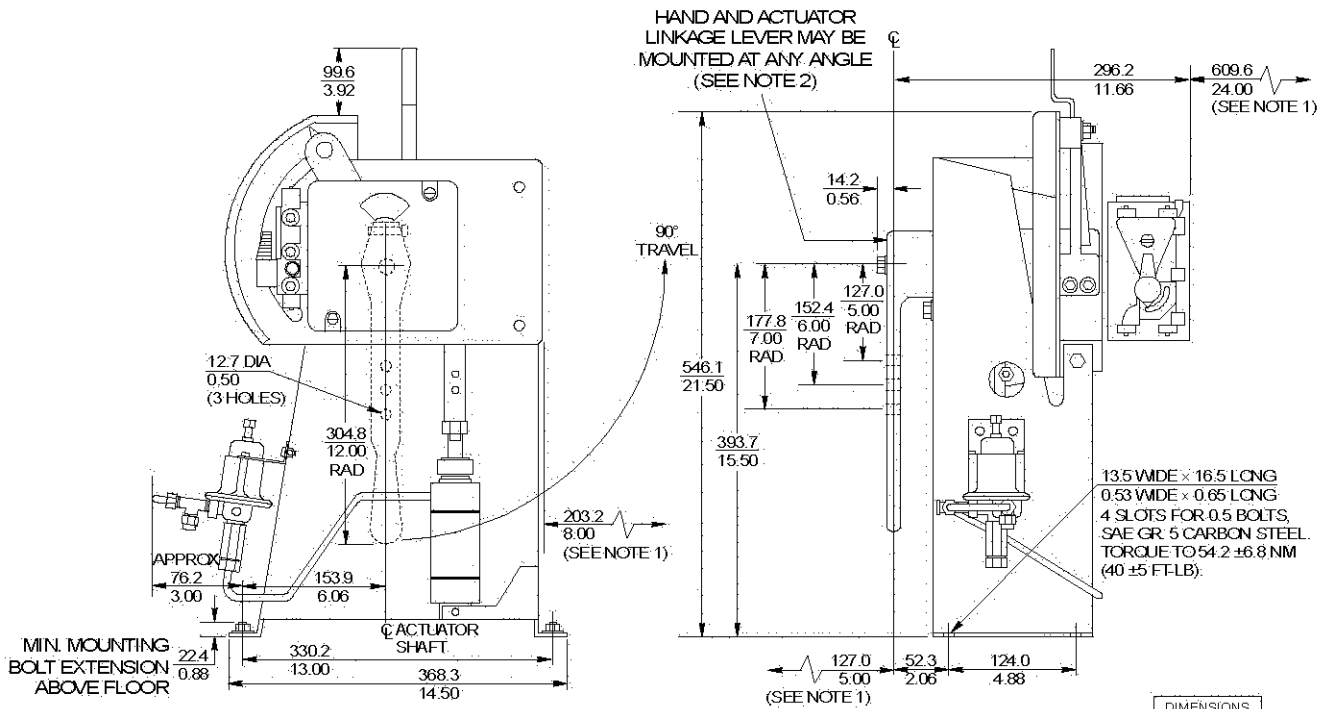

- NOTES:
1. MINIMUM CLEARANCE FOR ADJUSTMENT, INSPECTION, MAINTENANCE AND OPERATION REQUIRED.
  2. AFTER POSITIONING ACTUATOR LEVER, TORQUE TWO 0.375 IN. SOCKET HEAD CAP SCREWS TO 74.6 ± 2.7 NM (55 ± 2 FT-LB).
  3. MAXIMUM AMBIENT TEMPERATURE LIMIT = 82°C (180°F). SOME ACTUATOR/POSITIONER COMBINATIONS MAY HAVE A SLIGHTLY LOWER MAXIMUM AMBIENT TEMPERATURE LIMIT. REFER TO THE APPROPRIATE POSITIONER SPECIFICATION.

TP20115B

Fig. C.2: Type UP1 actuator with positioner and air failure lock (drawing no. TP20115B)

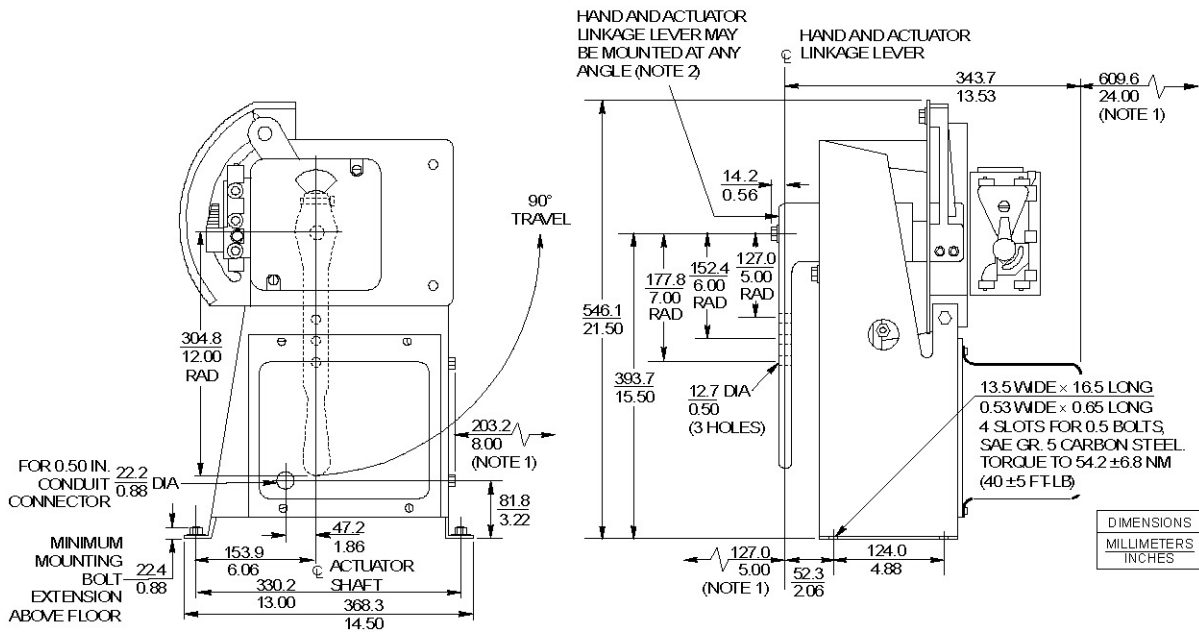

- NOTES:
1. MINIMUM CLEARANCE FOR ADJUSTMENT, INSPECTION, MAINTENANCE AND OPERATION REQUIRED.
  2. AFTER POSITIONING ACTUATOR LEVER, TORQUE TWO 0.375 in. SOCKET HEAD CAP SCREWS TO 67.8 ± 6.8 NM (50 ± 5 FT-LB).
  3. MAXIMUM AMBIENT TEMPERATURE LIMIT = 82°C (180°F). SOME ACTUATOR/POSITIONER COMBINATIONS MAY HAVE A SLIGHTLY LOWER MAXIMUM AMBIENT TEMPERATURE LIMIT. REFER TO THE APPROPRIATE POSITIONER SPECIFICATION.

TP20113B

Fig. C.3: Type UP1 actuator with positioner and / or alarm / travel switches (drawing no. TP20113B)



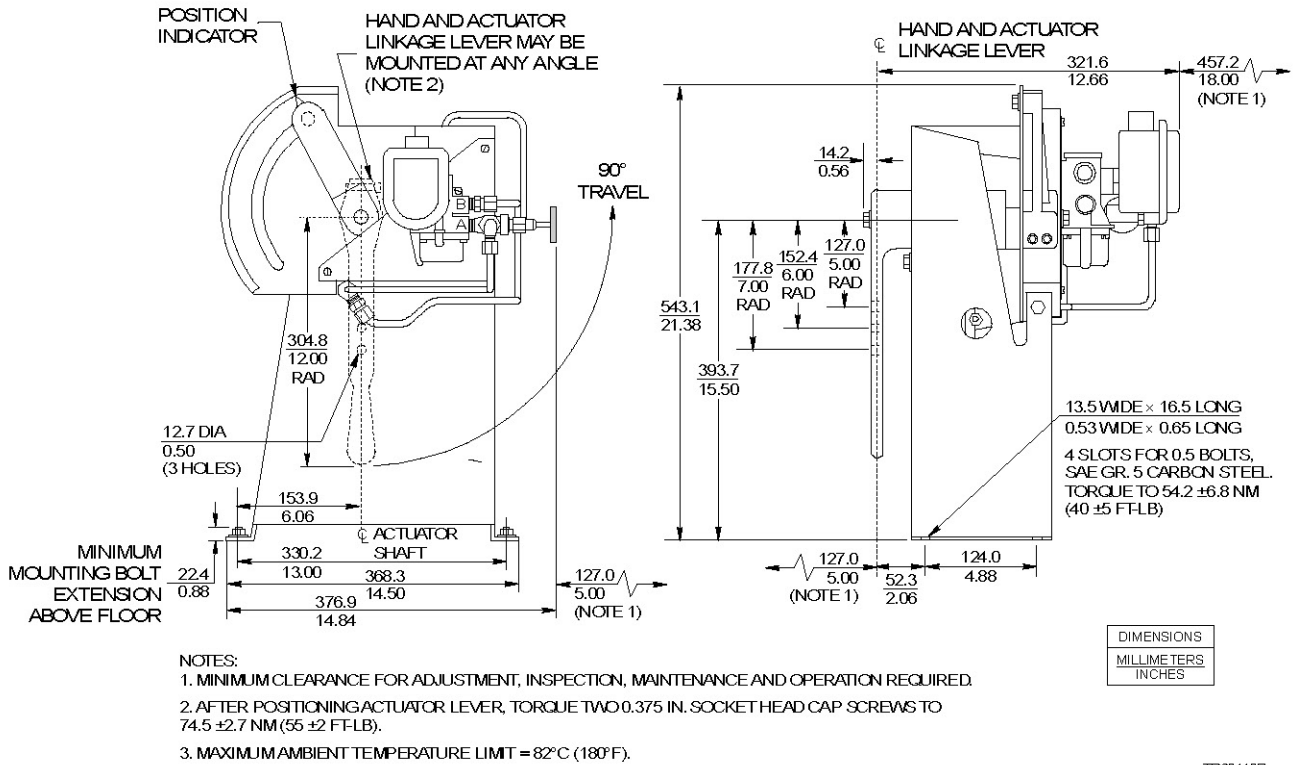

Fig. C.4: Type UP1 actuator with solenoid valve (drawing no. TP20110B)

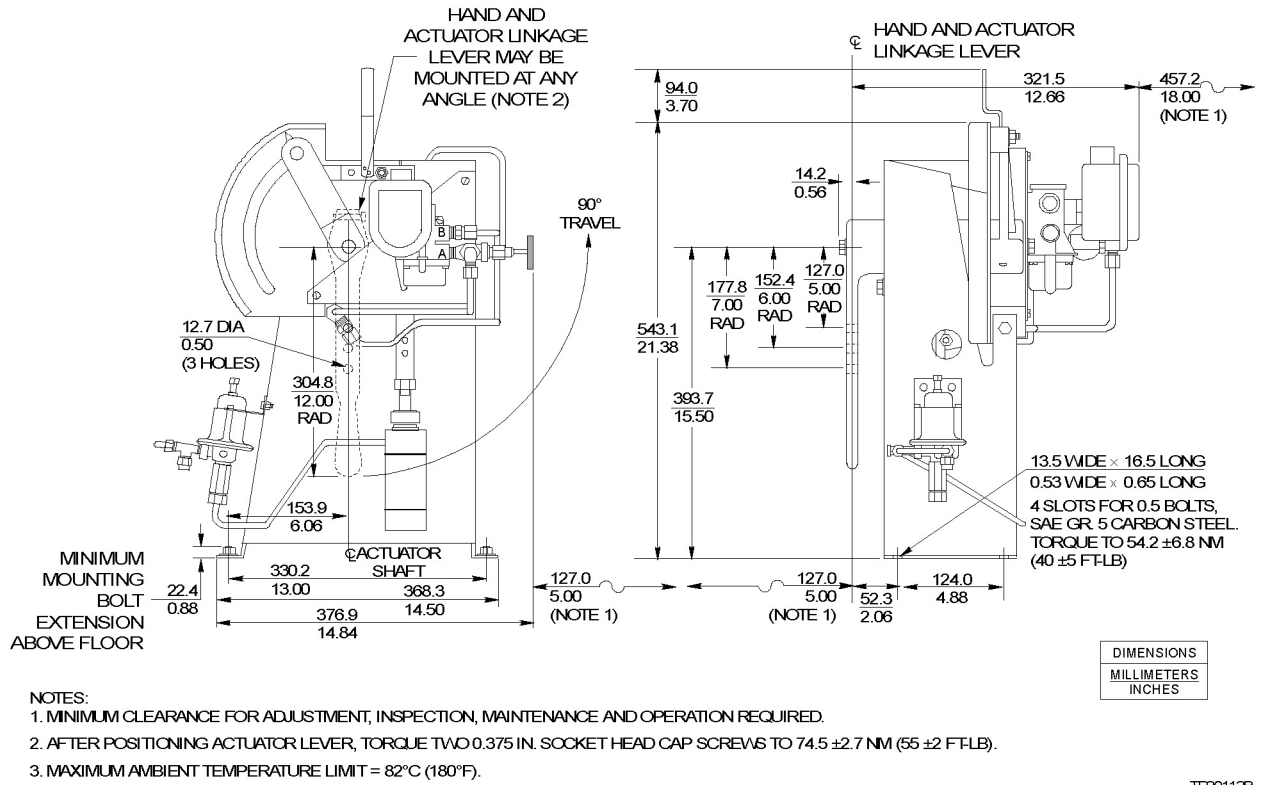
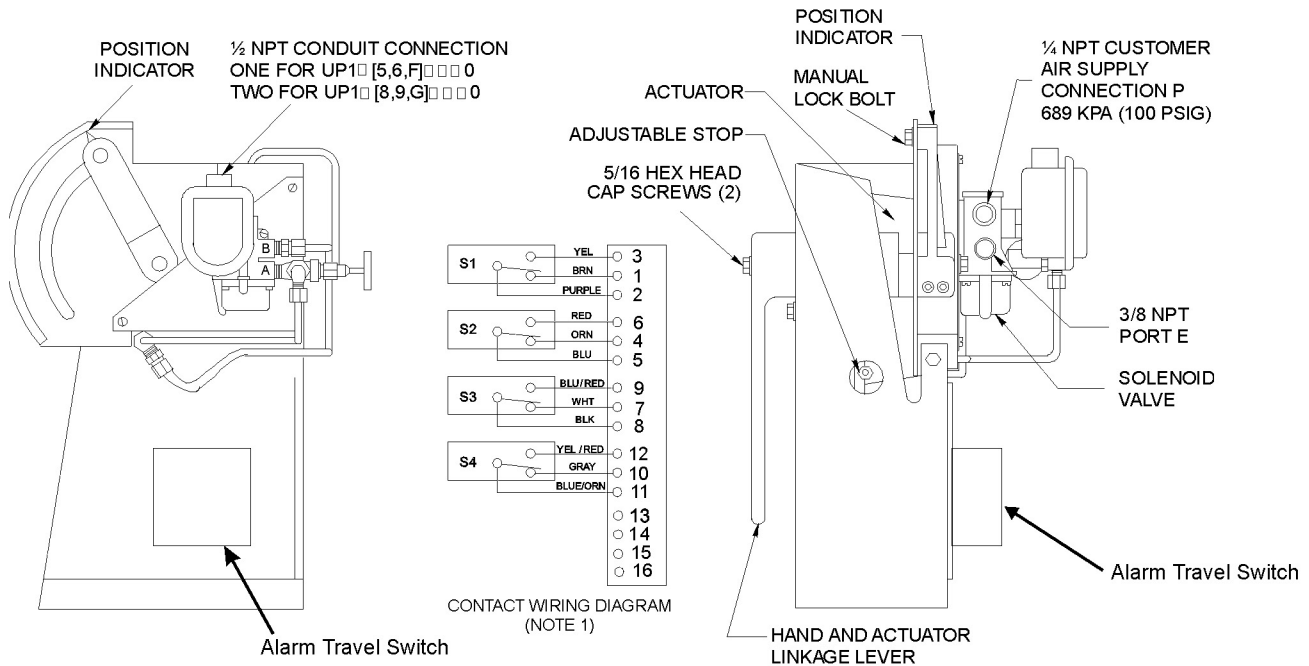

Fig. C.5: Type UP1 actuator with solenoid and air failure lock (drawing no. TP20112B)



TP20101C\_1

NOTES:  
1. CONTACTS MUST BE DERATED 1.5 A FOR EVERY 10°C (18°F) RISE ABOVE 60°C (140°F).

Fig. C.6: Type UP1 actuator with solenoid valve and / or alarm / travel switches (drawing no. TP20101C\_1)

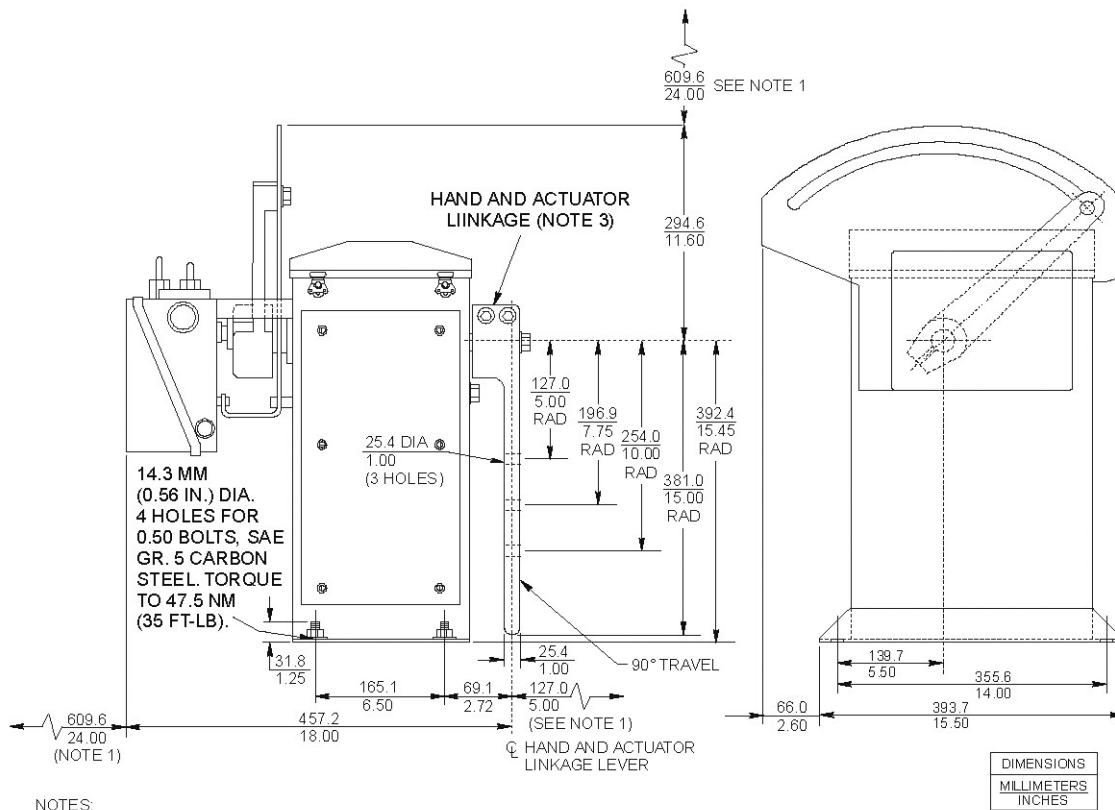

NOTES:  
1. MINIMUM CLEARANCE FOR ADJUSTMENT, INSPECTION, MAINTENANCE AND OPERATION REQUIRED.  
2. MAXIMUM AMBIENT TEMPERATURE LIMIT = 82°C (180°F). SOME ACTUATOR/POSITIONER COMBINATIONS MAY HAVE A SLIGHTLY LOWER MAXIMUM AMBIENT TEMPERATURE LIMIT. REFER TO THE APPROPRIATE POSITIONER SPECIFICATION.  
3. AFTER POSITIONING ACTUATOR LEVER, TORQUE TWO 0.50 SOCKET HEAD CAP SCREWS TO 88.13 NM (65 FT-LB).

TP20116A

Fig. C.7: Type UP2 actuator with Type AV positioner or solenoid valve (drawing no. TP20116A)

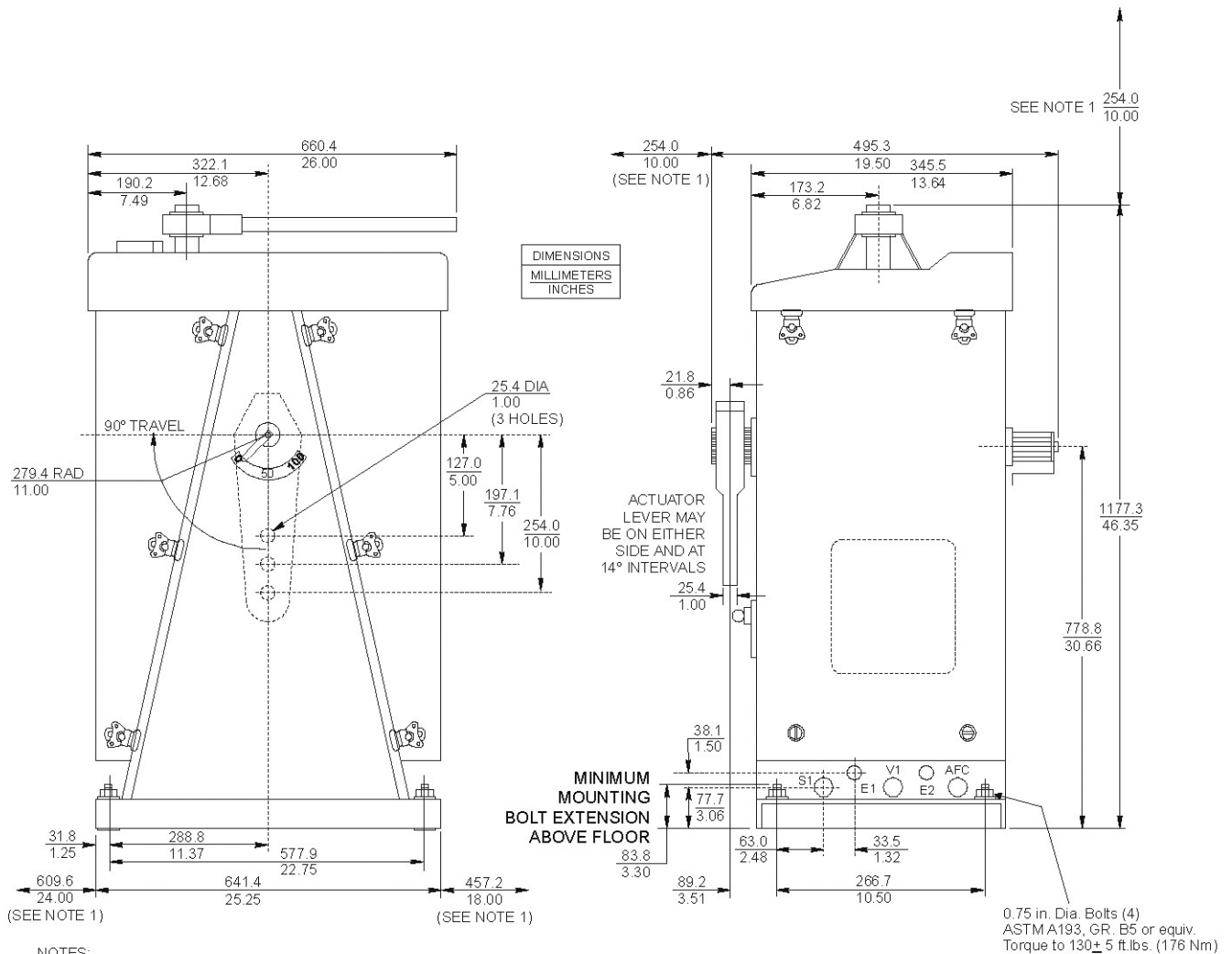

Fig. C.8: Types UP3 and UP4 actuators (page 1 of 2) (drawing no. TP20127C)

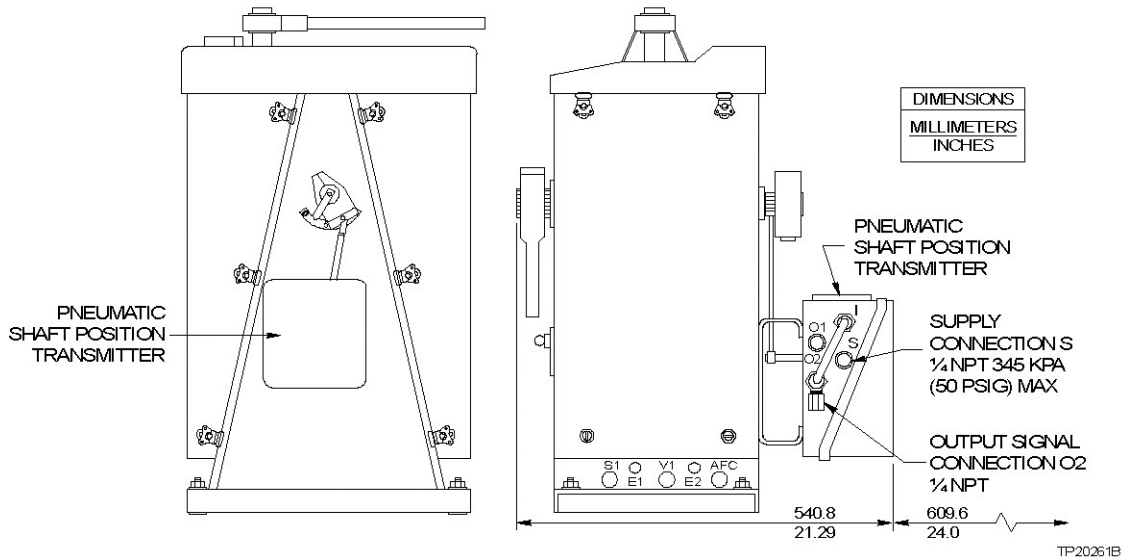
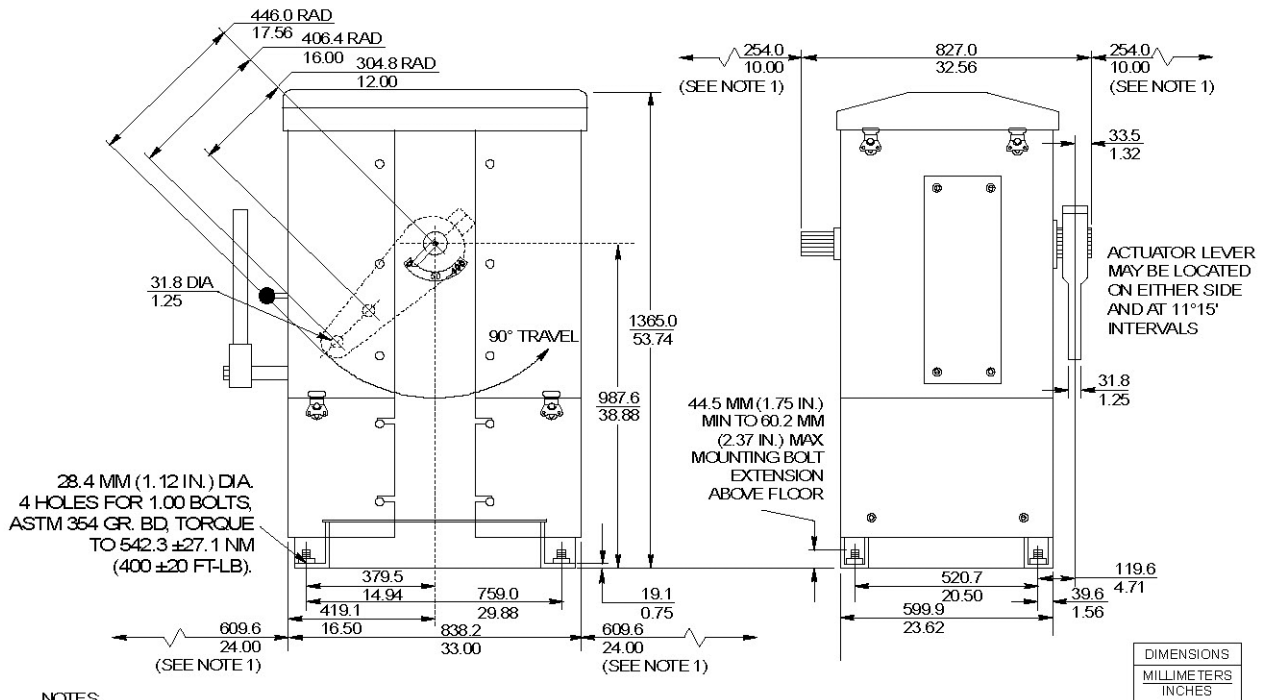

Fig. C.9: Types UP3 and UP4 actuators (Page 2 of 2) (drawing no. TP20261B)



NOTES:

1. MINIMUM CLEARANCE FOR ADJUSTMENTS, INSPECTION, MAINTENANCE AND OPERATION REQUIRED.
2. MAXIMUM AMBIENT TEMPERATURE LIMIT = 82°C (180°F). SOME ACTUATOR/POSITIONER COMBINATIONS MAY HAVE A SLIGHTLY LOWER MAXIMUM AMBIENT TEMPERATURE LIMIT. REFER TO THE APPROPRIATE POSITIONER SPECIFICATION.
3. NO OTHER WIRES SHALL BE IN CONDUIT USED FOR TYPE UP[5,6] [C,D,E] SIGNAL.
4. IF SHIELDED CABLE IS USED, SHIELD GROUNDING SHOULD BE CONSISTENT WITH SYSTEM REQUIREMENTS.
5. AFTER MOUNTING ACTUATOR IN PLACE, BUT BEFORE TIGHTENING MOUNTING BOLTS, SHIM SO THAT MOUNTING BOLTS, WHEN TIGHTENED, WILL NOT WARP FRAME. TEST BY NOTING FREEDOM OF ACTUATOR LEVER SHAFT WITH PISTON ROD CLEVIS PIN REMOVED SO THAT PISTON IS DISCONNECTED.

Fig. C.10: Types UP5, UP6 and UP7 actuators (drawing no. TP20117B)

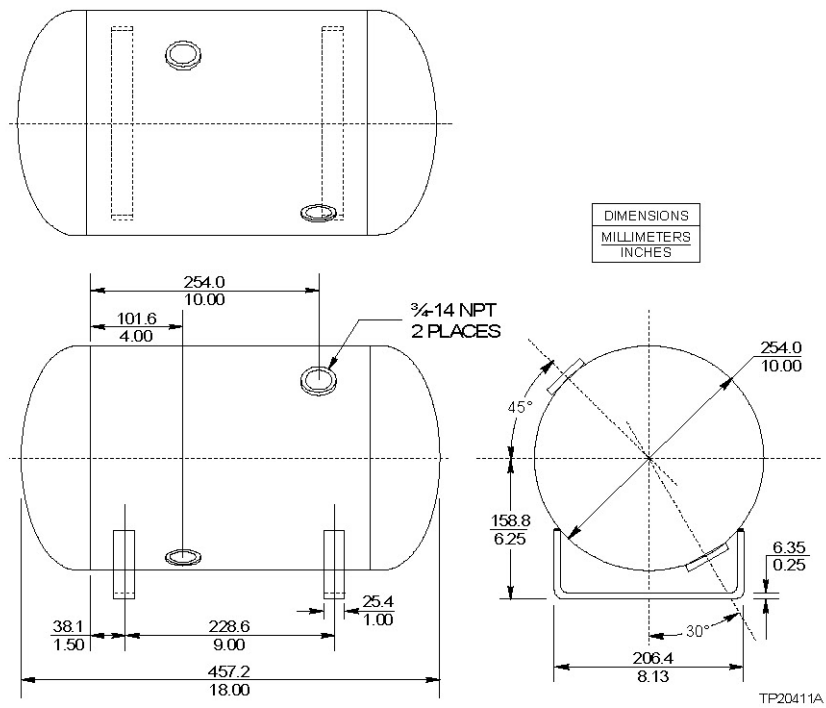

Fig. C.11: 20.8 l (5.5 gall.) reserve air Tank option for Type UP2 actuator (drawing no. TP20411A)

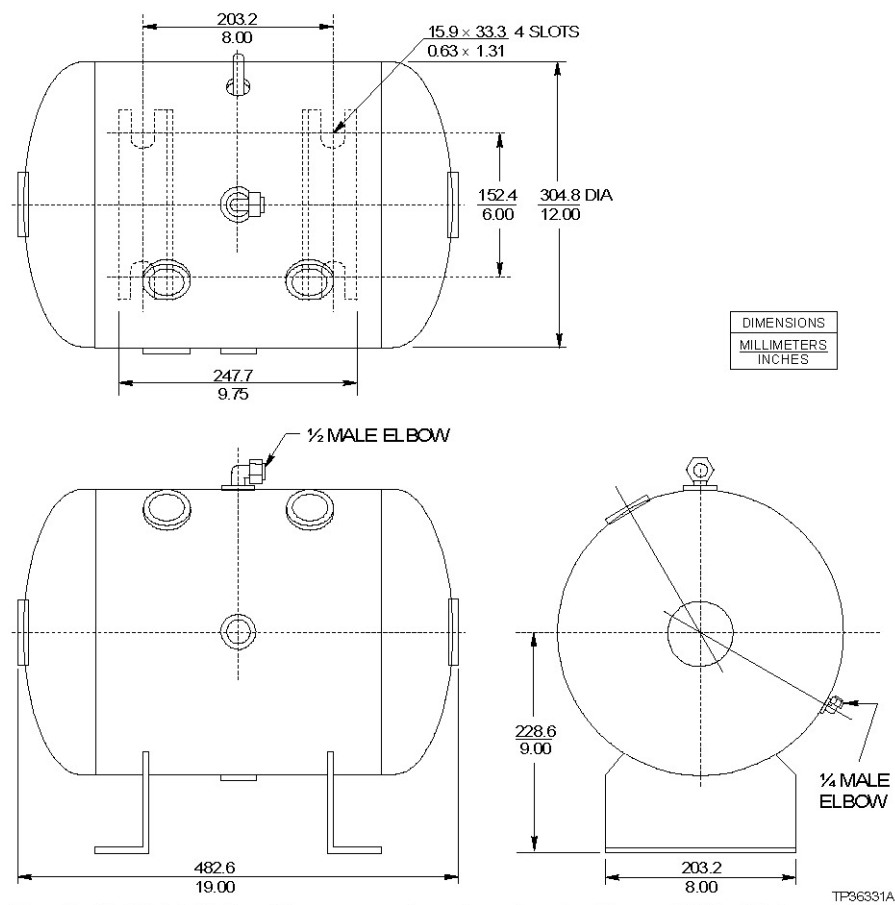

Fig. C.12: 30.3 l (8.0 gall.) reserve air tank option for Types UP3, UP4 and UP5 actuators (drawing no. TP36331A)

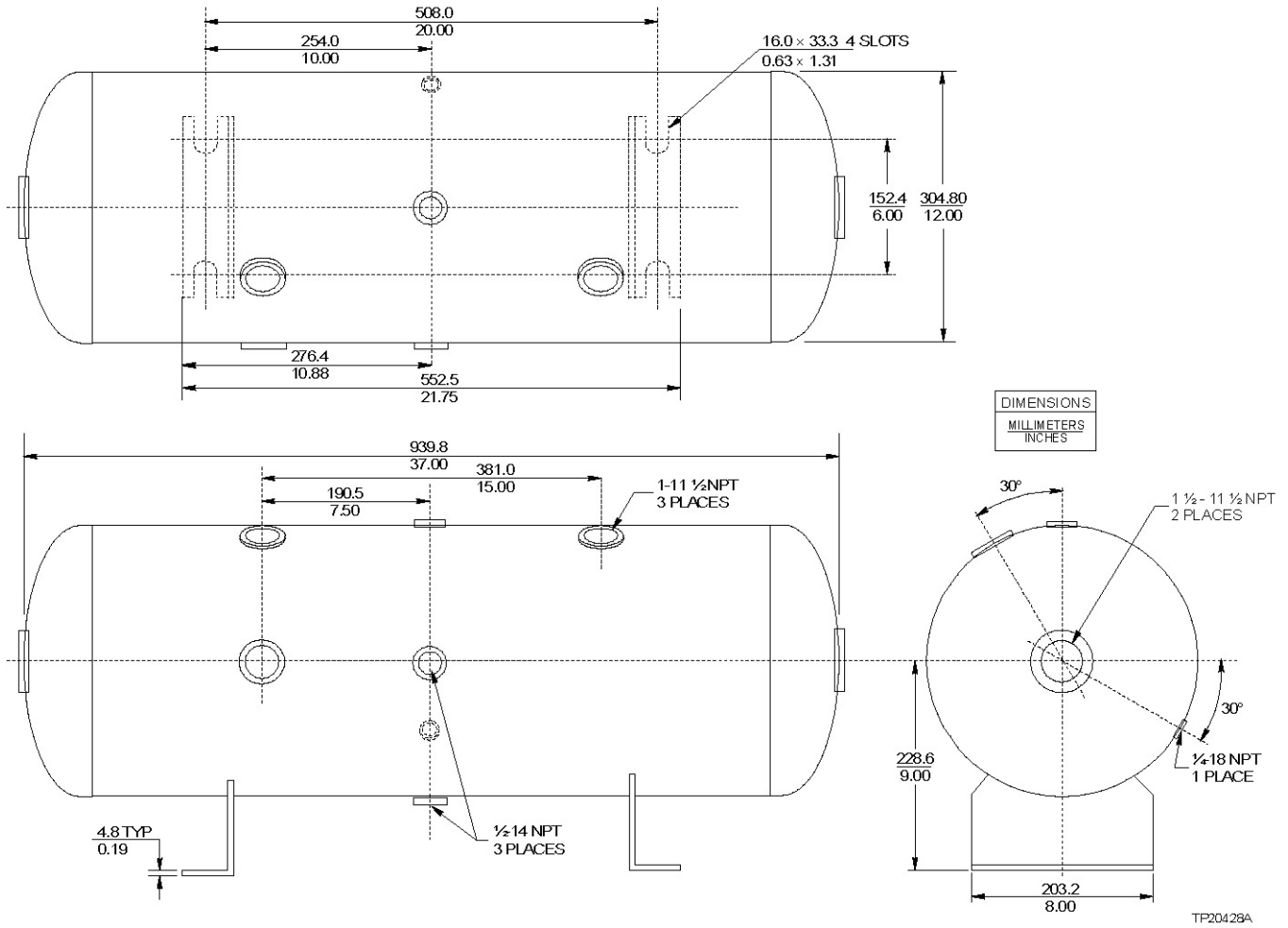

Fig. C.13: 64.4 l (17.0 gall.) reserve air tank for Type UP6 and UP7 actuators (drawing no. TP20428A)

## Appendix D – Air cylinder replacement

### D.1 Rotary vane and air cylinder repair and replacement

Models UP1 and UP2 actuators contain a double-acting rotary vane.

Models UP3 to UP7 actuators produced after 2008 use a permanently-lubricated, maintenance-free double-acting air cylinder assembly and have a corresponding seal repair kit available as shown below. The actuators can be identified by its silver-colored cylinder and square-end flanges.

Model	Replacement air cylinder	Seal repair kit for replacement air cylinder
UP1	5328575F1	258244A1
UP2	5328838A1	258244A2

Table D.1: Models UP1 to UP2

Model	Replacement air cylinder	Seal repair kit for replacement air cylinder
UP3	614B069U33	614B069U26
UP4	614B069U34	614B069U28
UP5	614B069U35	614B069U28
UP6	614B069U36	614B069U30
UP7	CF	CF

Table D.2: Models UP3 to UP7

# Appendix E – Additional pneumatic arrangement drawings

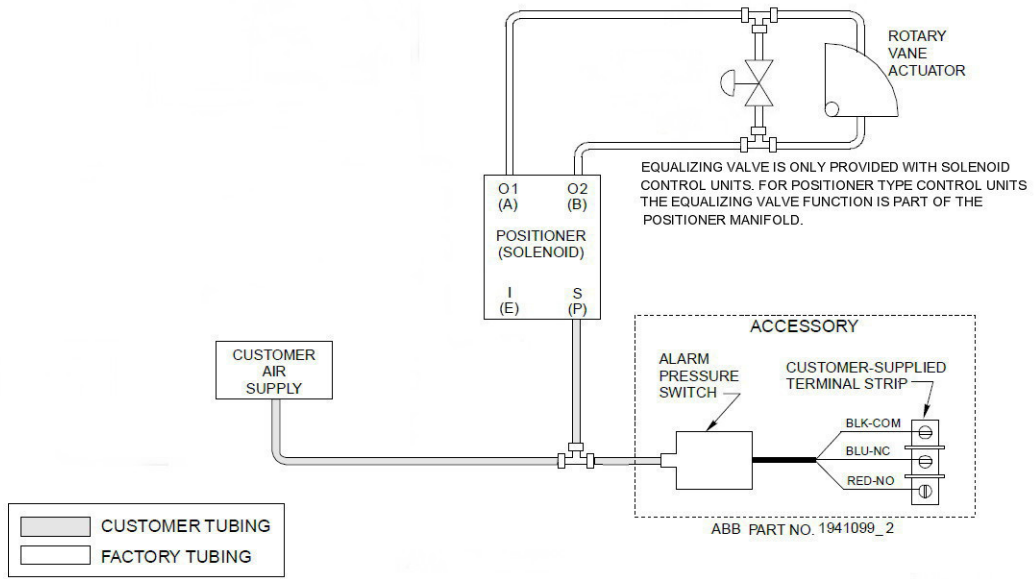

AIR FAILURE CONTROL = 0 FOR UP1 & UP2

AIR FAILURE CONTROL = '0' MEANS NO AIR FAILURE LOCK CONTROL

TPSC2015UP\_2

Fig. E.1: UP1 and UP2 pneumatic arrangement without air failure control options



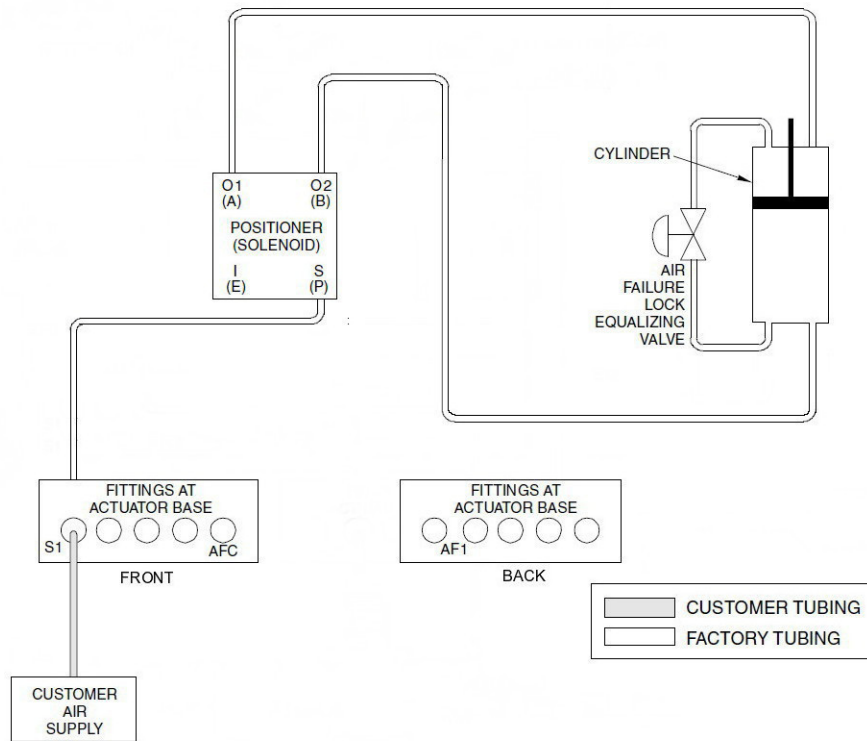

AIR FAILURE CONTROL = 0 (NONE) FOR:  
 UP3, UP4, UP5, UP6, & UP7 (EXCEPT FOR UP5, UP6, & UP7 WITH TZID-C OR EDP300 POSITIONERS).

TPSC2015UP\_9

Fig. E.2: UP3 to UP7 pneumatic arrangement with AV positioner, without air failure control options

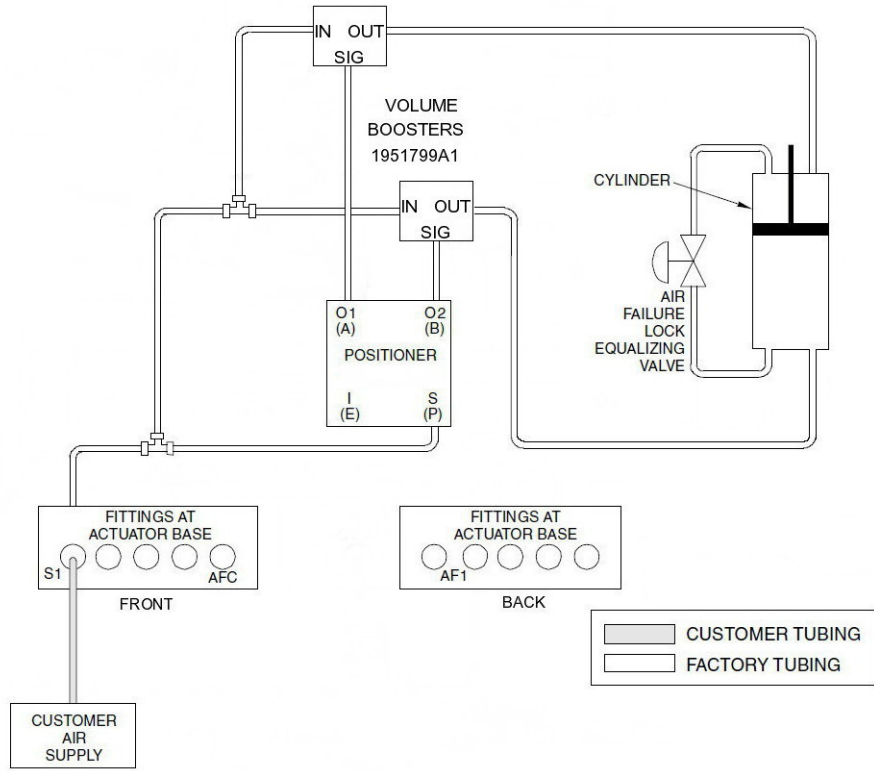

AIR FAILURE CONTROL = 0 (NONE) FOR:  
 UP5, UP6, & UP7 WITH TZID-C OR EDP300 POSITIONERS

TPSC2015UP\_10

Fig. E.3: UP5 to UP7 pneumatic arrangement with TZIDC or EDP300 positioner, without air failure control options

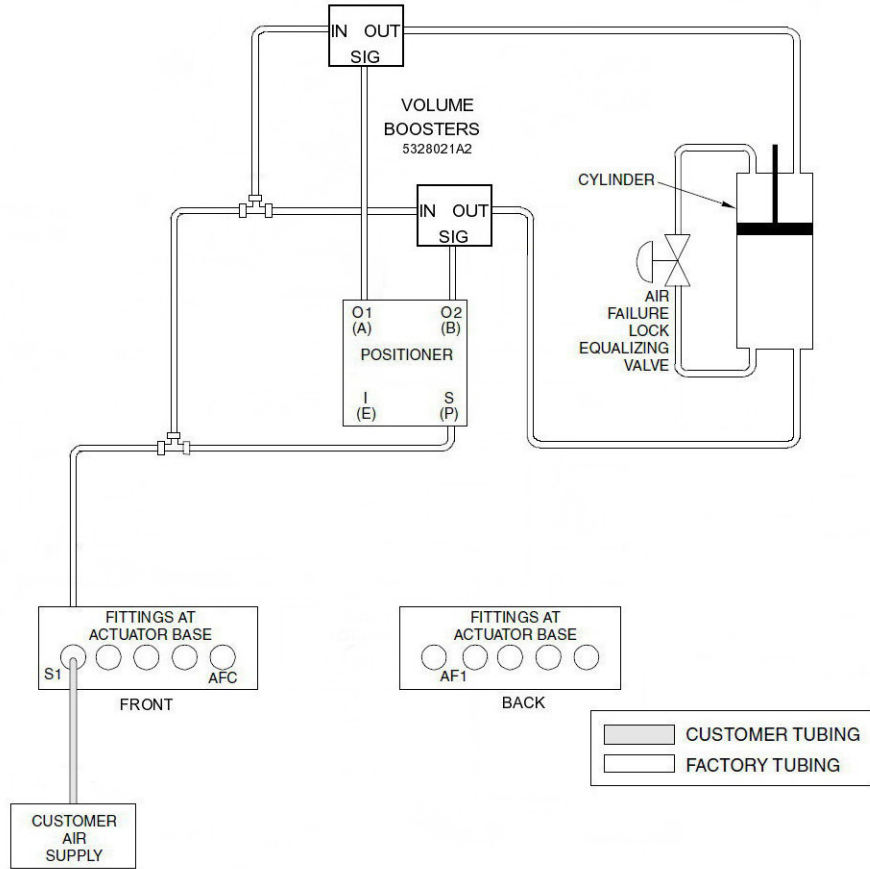

UP6, & UP7 AIR FAILURE CONTROL = 2 : VOLUME BOOSTERS FOR FAST TRAVEL

TPSC2015UP\_19

Fig. E.4: UP6 and UP7 pneumatic arrangement with volume boosters for fast travel option

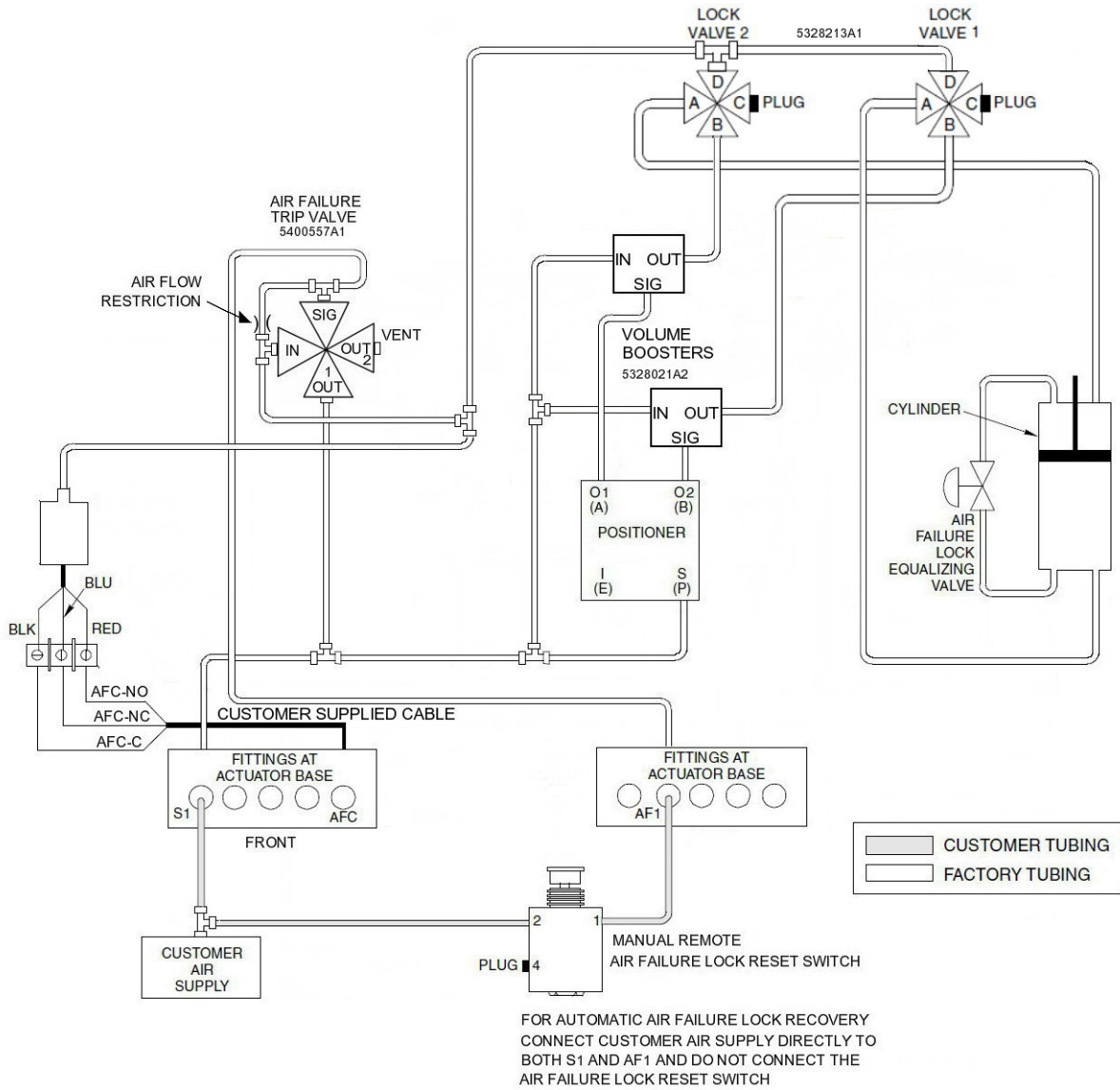

UP6, & UP7 AIR FAILURE CONTROL = 3 AIR FAILURE LOCK + VOLUME BOOSTERS (HOLD LAST POSITION UPON LOSS OF AIR SUPPLY) WITH MANUAL OR AUTOMATIC RESET FUNCTION AFTER AIR RECOVERY (INCLUDES REMOTE RESET SWITCH AND PRESSURE SWITCH).

TPSC2015UP\_20

Fig. E.5: UP6 and UP7 pneumatic arrangement with are failure lock and volume boosters for fast travel with manual or automatic reset after air recovery

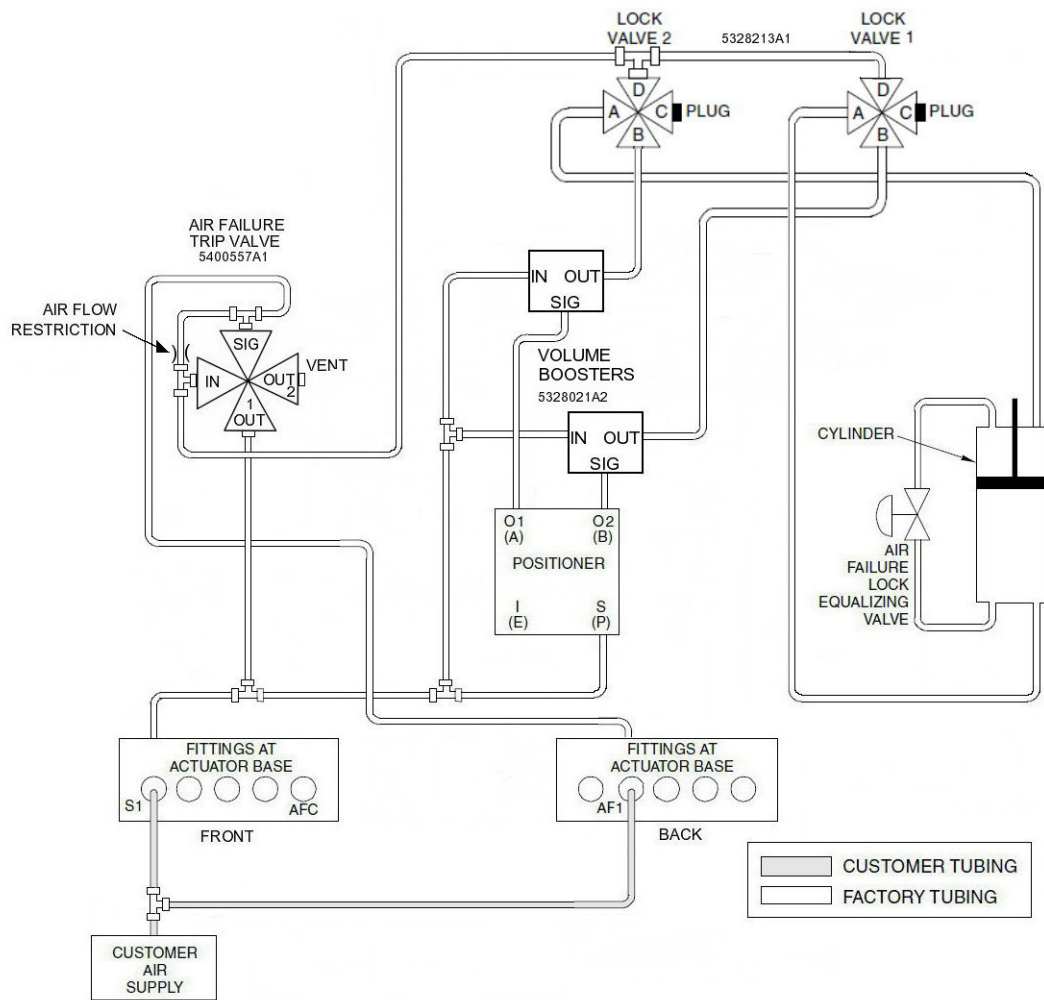

UP6, & UP7 AIR FAILURE CONTROL = B : AIR FAILURE LOCK UP + VOLUME BOOSTERS (HOLD LAST POSITION UPON LOSS OF AIR SUPPLY) WITH AUTOMATIC RESET UPON AIR RECOVERY, WITHOUT PRESSURE SWITCH FOR AIR FAILURE ALARM.

TPSC2015UP\_21

Fig. E.6: UP6 and UP7 pneumatic arrangement with are failure lock and volume boosters for fast travel without pressure switch for air failure alarm



# Notes

# Contact us

## **ABB Limited**

### **Process Automation**

Salterbeck Trading Estate  
Workington, Cumbria  
CA14 5DS  
UK

Tel: +44 (0)1946 830 611

Fax: +44 (0)1946 832 661

## **ABB Inc.**

### **Process Automation**

125 E. County Line Road  
Warminster, PA 18974  
USA

Tel: +1 215 674 6000

Fax: +1 215 674 7183

## **ABB Automation Products GmbH**

### **Process Automation**

Schillerstr. 72  
32425 Minden  
Deutschland

Tel: +49 551 905 534

Fax: +49 551 905 555

[www.abb.com](http://www.abb.com)

## Note

We reserve the right to make technical changes or modify the contents of this document without prior notice. With regard to purchase orders, the agreed particulars shall prevail. ABB does not accept any responsibility whatsoever for potential errors or possible lack of information in this document.

We reserve all rights in this document and in the subject matter and illustrations contained therein. Any reproduction, disclosure to third parties or utilization of its contents in whole or in parts – is forbidden without prior written consent of ABB.

Copyright© 2015 ABB

All rights reserved