

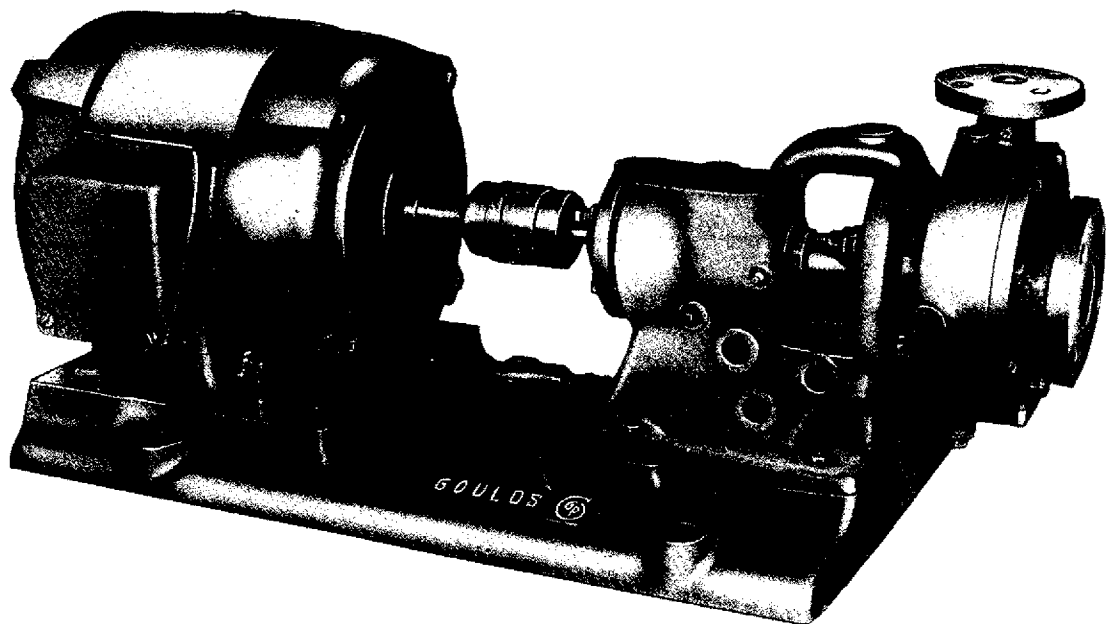

GOULDS PUMPS

Installation, Operation and Maintenance Instructions

MODEL 3199



ITT

FOREWORD

To provide industry with a line of rugged, dependable, open impeller end suction pumps, Goulds developed the Model 3199.

The life and satisfactory service of any mechanical unit, however, is enhanced and extended by correct application, proper installation, periodic inspection and maintenance. This instruction book was prepared so operators will understand the construction and the correct method for installing, operating and maintaining these pumps.

Read thoroughly Sections I, II, III, and IV and be sure to follow the instructions for installation and operation. Sections V and VI are answers to trouble and maintainance questions. Keep this instruction book handy for reference. Kindly direct any questions or suggestions to the attention of the Engineering Application Division, Goulds Pumps Inc., Seneca Falls, N.Y.

IMPORTANT SAFETY NOTICE

To: Our Valued Customers

User safety is a major focus in the design of our products. Following the precautions outlined in this manual will minimize your risk of injury.

ITT Goulds pumps will provide safe, trouble-free service when properly installed, maintained, and operated.

Safe installation, operation, and maintenance of ITT Goulds Pumps equipment are an essential end user responsibility. This *Pump Safety Manual* identifies specific safety risks that must be considered at all times during product life. Understanding and adhering to these safety warnings is mandatory to ensure personnel, property, and/or the environment will not be harmed. Adherence to these warnings alone, however, is not sufficient — it is anticipated that the end user will also comply with industry and corporate safety standards. Identifying and eliminating unsafe installation, operating and maintenance practices is the responsibility of all individuals involved in the installation, operation, and maintenance of industrial equipment.

Please take the time to review and understand the safe installation, operation, and maintenance guidelines outlined in this Pump Safety Manual and the Instruction, Operation, and Maintenance (IOM) manual. Current manuals are available at www.gouldspumps.com/literature_ioms.html or by contacting your nearest Goulds Pumps sales representative.

These manuals must be read and understood before installation and start-up.

For additional information, contact your nearest Goulds Pumps sales representative or visit our Web site at www.gouldspumps.com.

SAFETY WARNINGS

Specific to pumping equipment, significant risks bear reinforcement above and beyond normal safety precautions.

 **WARNING**

A pump is a pressure vessel with rotating parts that can be hazardous. Any pressure vessel can explode, rupture, or discharge its contents if sufficiently over pressurized causing death, personal injury, property damage, and/or damage to the environment. All necessary measures must be taken to ensure over pressurization does not occur.

 **WARNING**

Operation of any pumping system with a blocked suction and discharge must be avoided in all cases. Operation, even for a brief period under these conditions, can cause superheating of enclosed pumpage and result in a violent explosion. All necessary measures must be taken by the end user to ensure this condition is avoided.

 **WARNING**

The pump may handle hazardous and/or toxic fluids. Care must be taken to identify the contents of the pump and eliminate the possibility of exposure, particularly if hazardous and/or toxic. Potential hazards include, but are not limited to, high temperature, flammable, acidic, caustic, explosive, and other risks.

 **WARNING**

Pumping equipment Instruction, Operation, and Maintenance manuals clearly identify accepted methods for disassembling pumping units. These methods must be adhered to. Specifically, applying heat to impellers and/or impeller retaining devices to aid in their removal is strictly forbidden. Trapped liquid can rapidly expand and result in a violent explosion and injury.

ITT Goulds Pumps will not accept responsibility for physical injury, damage, or delays caused by a failure to observe the instructions for installation, operation, and maintenance contained in this Pump Safety Manual or the current IOM available at www.gouldspumps.com/literature.

SAFETY

DEFINITIONS

Throughout this manual the words **WARNING**, **CAUTION**, **ELECTRICAL**, and **ATEX** are used to indicate where special operator attention is required.

Observe all Cautions and Warnings highlighted in this Pump Safety Manual and the IOM provided with your equipment.



WARNING

Indicates a hazardous situation which, if not avoided, could result in death or serious injury.

Example: Pump shall never be operated without coupling guard installed correctly.



CAUTION

Indicates a hazardous situation which, if not avoided, could result in minor or moderate injury.

Example: Throttling flow from the suction side may cause cavitation and pump damage.



ELECTRICAL HAZARD

Indicates the possibility of electrical risks if directions are not followed.

Example: Lock out driver power to prevent electric shock, accidental start-up, and physical injury.









When installed in potentially explosive atmospheres, the instructions that follow the Ex symbol must be followed. Personal injury and/or equipment damage may occur if these instructions are not followed. If there is any question regarding these requirements or if the equipment is to be modified, please contact an ITT Goulds Pumps representative before proceeding.













Example:  Improper impeller adjustment could cause contact between the rotating and stationary parts, resulting in a spark and heat generation.



GENERAL PRECAUTIONS

WARNING

A pump is a pressure vessel with rotating parts that can be hazardous. Hazardous fluids may be contained by the pump including high temperature, flammable, acidic, caustic, explosive, and other risks. Operators and maintenance personnel must realize this and follow safety measures. Personal injuries will result if procedures outlined in this manual are not followed. ITT Goulds Pumps will not accept responsibility for physical injury, damage or delays caused by a failure to observe the instructions in this manual and the IOM provided with your equipment.

General Precautions		
WARNING		NEVER APPLY HEAT TO REMOVE IMPELLER. It may explode due to trapped liquid.
WARNING		NEVER use heat to disassemble pump due to risk of explosion from tapped liquid.
WARNING		NEVER operate pump without coupling guard correctly installed.
WARNING		NEVER run pump below recommended minimum flow when dry, or without prime.
WARNING		ALWAYS lock out power to the driver before performing pump maintenance.
WARNING		NEVER operate pump without safety devices installed.
WARNING		NEVER operate pump with discharge valve closed.
WARNING		NEVER operate pump with suction valve closed.
WARNING		DO NOT change service application without approval of an authorized ITT Goulds Pumps representative.
WARNING		<p>Safety Apparel:</p> <ul style="list-style-type: none"> ♦ Insulated work gloves when handling hot bearings or using bearing heater ♦ Heavy work gloves when handling parts with sharp edges, especially impellers ♦ Safety glasses (with side shields) for eye protection ♦ Steel-toed shoes for foot protection when handling parts, heavy tools, etc. ♦ Other personal protective equipment to protect against hazardous/toxic fluids
WARNING		<p>Receiving:</p> <p>Assembled pumping units and their components are heavy. Failure to properly lift and support equipment can result in serious physical injury and/or equipment damage. Lift equipment only at specifically identified lifting points or as instructed in the current IOM. Current manuals are available at www.gouldspumps.com/literature_ioms.html or from your local ITT Goulds Pumps sales representative. Note: Lifting devices (eyebolts, slings, spreaders, etc.) must be rated, selected, and used for the entire load being lifted.</p>
WARNING		<p>Alignment:</p> <p>Shaft alignment procedures must be followed to prevent catastrophic failure of drive components or unintended contact of rotating parts. Follow coupling manufacturer's coupling installation and operation procedures.</p>

General Precautions		
WARNING		Before beginning any alignment procedure, make sure driver power is locked out. Failure to lock out driver power will result in serious physical injury.
CAUTION		Piping: Never draw piping into place by forcing at the flanged connections of the pump. This may impose dangerous strains on the unit and cause misalignment between pump and driver. Pipe strain will adversely effect the operation of the pump resulting in physical injury and damage to the equipment.
WARNING		Flanged Connections: Use only fasteners of the proper size and material.
WARNING		Replace all corroded fasteners.
WARNING		Ensure all fasteners are properly tightened and there are no missing fasteners.
WARNING		Startup and Operation: When installing in a potentially explosive environment, please ensure that the motor is properly certified.
WARNING		Operating pump in reverse rotation may result in contact of metal parts, heat generation, and breach of containment.
WARNING		Lock out driver power to prevent accidental start-up and physical injury.
WARNING		The impeller clearance setting procedure must be followed. Improperly setting the clearance or not following any of the proper procedures can result in sparks, unexpected heat generation and equipment damage.
WARNING		If using a cartridge mechanical seal, the centering clips must be installed and set screws loosened prior to setting impeller clearance. Failure to do so could result in sparks, heat generation, and mechanical seal damage.
WARNING		The coupling used in an ATEX classified environment must be properly certified and must be constructed from a non-sparking material.
WARNING		Never operate a pump without coupling guard properly installed. Personal injury will occur if pump is run without coupling guard.
WARNING		Make sure to properly lubricate the bearings. Failure to do so may result in excess heat generation, sparks, and / or premature failure.
CAUTION		The mechanical seal used in an ATEX classified environment must be properly certified. Prior to start up, ensure all points of potential leakage of process fluid to the work environment are closed.
CAUTION		Never operate the pump without liquid supplied to mechanical seal. Running a mechanical seal dry, even for a few seconds, can cause seal damage and must be avoided. Physical injury can occur if mechanical seal fails.
WARNING		Never attempt to replace packing until the driver is properly locked out and the coupling spacer is removed.
WARNING		Dynamic seals are not allowed in an ATEX classified environment.
WARNING		DO NOT operate pump below minimum rated flows or with suction and/or discharge valve closed. These conditions may create an explosive hazard due to vaporization of pumpage and can quickly lead to pump failure and physical injury.

General Precautions		
WARNING		Ensure pump is isolated from system and pressure is relieved before disassembling pump, removing plugs, opening vent or drain valves, or disconnecting piping.
WARNING		Shutdown, Disassembly, and Reassembly: Pump components can be heavy. Proper methods of lifting must be employed to avoid physical injury and/or equipment damage. Steel toed shoes must be worn at all times.
WARNING		The pump may handle hazardous and/or toxic fluids. Observe proper decontamination procedures. Proper personal protective equipment should be worn. Precautions must be taken to prevent physical injury. Pumpage must be handled and disposed of in conformance with applicable environmental regulations.
WARNING		Operator must be aware of pumpage and safety precautions to prevent physical injury.
WARNING		Lock out driver power to prevent accidental startup and physical injury.
CAUTION		Allow all system and pump components to cool before handling them to prevent physical injury.
CAUTION		If pump is a Model NM3171, NM3196, 3198, 3298, V3298, SP3298, 4150, 4550, or 3107, there may be a risk of static electric discharge from plastic parts that are not properly grounded. If pumped fluid is non-conductive, pump should be drained and flushed with a conductive fluid under conditions that will not allow for a spark to be released to the atmosphere.
WARNING		Never apply heat to remove an impeller. The use of heat may cause an explosion due to trapped fluid, resulting in severe physical injury and property damage.
CAUTION		Wear heavy work gloves when handling impellers as sharp edges may cause physical injury.
CAUTION		Wear insulated gloves when using a bearing heater. Bearings will get hot and can cause physical injury.

ATEX CONSIDERATIONS and INTENDED USE

Special care must be taken in potentially explosive environments to ensure that the equipment is properly maintained. This includes but is not limited to:

1. Monitoring the pump frame and liquid end temperature.
2. Maintaining proper bearing lubrication.
3. Ensuring that the pump is operated in the intended hydraulic range.

The ATEX conformance is only applicable when the pump unit is operated within its intended use. Operating, installing or maintaining the pump unit in any way that is not covered in the Instruction, Operation, and Maintenance manual (IOM) can cause serious personal injury or damage to the equipment. This includes any modification to the equipment or use of parts not provided by ITT Goulds Pumps. If there is any question regarding the intended use of the equipment, please contact an ITT Goulds representative before proceeding. Current IOMs are available at www.gouldspumps.com/literature_ioms.html or from your local ITT Goulds Pumps Sales representative.

All pumping unit (pump, seal, coupling, motor and pump accessories) certified for use in an ATEX classified environment, are identified by an ATEX tag secured to the pump or the baseplate on which it is mounted. A typical tag would look like this:



The CE and the Ex designate the ATEX compliance. The code directly below these symbols reads as follows:

- II = Group 2
- 2 = Category 2
- G/D = Gas and Dust present
- T4 = Temperature class, can be T1 to T6 (see Table 1)

Code	Max permissible surface temperature °F (°C)	Max permissible liquid temperature °F (°C)
T1	842 (450)	700 (372)
T2	572 (300)	530 (277)
T3	392 (200)	350 (177)
T4	275 (135)	235 (113)
T5	212 (100)	Option not available
T6	185 (85)	Option not available

The code classification marked on the equipment must be in accordance with the specified area where the equipment will be installed. If it is not, do not operate the equipment and contact your ITT Goulds Pumps sales representative before proceeding.

PARTS

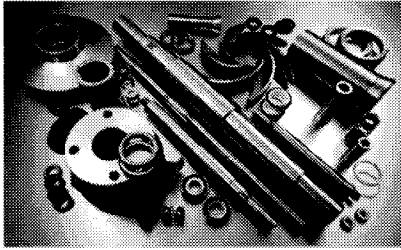

The use of genuine Goulds parts will provide the safest and most reliable operation of your pump. ITT Goulds Pumps ISO certification and quality control procedures ensure the parts are manufactured to the highest quality and safety levels.

Please contact your local Goulds representative for details on genuine Goulds parts.

TABLE OF CONTENTS

SECTION I—INSTALLATION	PAGE	SECTION IV—OPERATION	PAGE
I—A Location of Pumping Unit	1	IV—A Stuffing Box	10
I—B Foundation	1	IV—B Operating at Reduced Capacities	10
I—C Alignment—Initial	2	IV—C Operating at Reduced Head	11
I—D Piping—General	4	IV—D Operating with Surge Conditions in Line ..	11
I—E Piping—Suction	4	IV—E Operating Under Freezing Conditions ..	11
I—F Piping Discharge	5		
I—G Connection of Piping	5	SECTION V—TROUBLE CHECK LIST	
I—H Check Rotation	6	V—A No Liquid Delivered	12
I—J Connection of Coupling	6	V—B Not Enough Liquid Delivered	12
		V—C Not Enough Pressure	12
SECTION II—PREPARATION FOR OPERATION		V—D Pump Works Awhile and Then Quits	12
II—A Pump Bearings	6	V—E Pump Takes Too Much Power	13
II—B Driver Bearings	6	V—F Pump Leaks Excessively at Stuffing Box ..	13
II—C Stuffing Box	6	V—G Pump is Noisy	13
II—D Connection of Seal Water Piping or Grease Lubricator	7	SECTION VI—CARE AND MAINTENANCE	
II—E Connection of Piping to Quenching Gland	8	VI—A Lubrication	14
II—F Connection of Cooling Water Piping	8	VI—B Repacking Stuffing Box	14
II—G Connection of Drain Piping	8	VI—C Adjusting Impeller Clearance	14
		VI—D Sectional Assembly	17
SECTION III—STARTING PUMP		Parts List and Interchangeability Chart ..	18
III—A Cooling and Flushing Flows.....	9	VI—E Replacing Impeller	15
III—B Check For Free Turning.....	9	VI—F Replacing Shaft or Bearings	16
III—C Priming	9	VI—G Replacing Casing	20
III—D Adjustment of Stuffing Box Gland.....	9	VI—H Spare Parts	20
III—E Alignment—Final	9	VI—I Instructions for Ordering Spare Parts	20
III—F Doweling	9		

SECTION I—INSTALLATION

I—A. LOCATION.

Pumping unit should be placed as close as practical to the source of supply. Head room and floor space allotted to the pumping unit should be sufficient for inspection and maintenance.

I—B. FOUNDATION.

1. The foundation should be substantial in order to absorb any vibration and to form a permanent rigid support for the bedplate. A concrete foundation poured on a solid footing, using a one-three-five mix of liberal thickness to support the pumping unit, is satisfactory.

2. Foundation Bolts:

- (a) The location and size of the foundation bolts is shown on the outline assembly drawing supplied for the pumping unit.
- (b) Each bolt should be installed with a pipe sleeve around it—to allow for adjustment. The inside sleeve diameter should be $2\frac{1}{2}$ to 3 times the diameter of the bolt. Place a

washer between bolt head and sleeve to hold bolt in position. See Fig. 1. Stuff waste around foundation bolts to prevent concrete from entering between the bolt and pipe sleeve.

- (c) The foundation bolts should be of sufficient length so that they project through the nuts approximately $\frac{1}{4}$ " after allowance has been made for grouting ($\frac{3}{4}$ " to $1\frac{1}{2}$ "), the thickness of the bedplate, and the thickness of the foundation bolt nut. See Fig. 1.

3. Preparing Foundation for Mounting:

- (a) Prior to setting unit upon the foundation, clean the top surface of concrete.

4. Mounting Unit on Foundation:

- (a) Put the pumping unit in place on the wedges furnished. The wedges should be placed at four points, two below the approximate center of the pump and two below the approximate center of the driver (See Fig. 2).

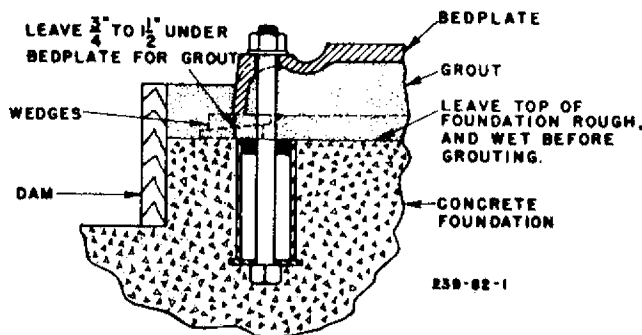

Fig. 1

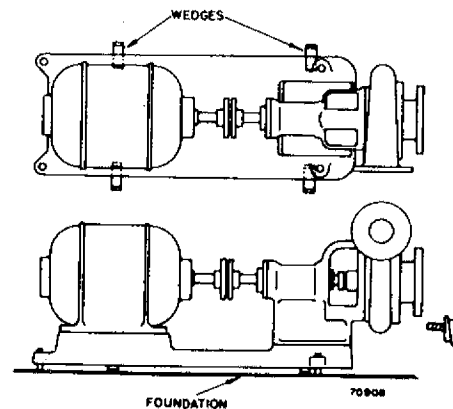

Fig. 2

- (b) Disconnect coupling between pump and driver if other than "insert-spider" type.
- (c) By adjustment of the wedges, bring the unit to an approximate level and provide for the proper distance above the foundation for grouting ($\frac{3}{4}$ " to $1\frac{1}{2}$ "). Level or plumb the suction and discharge flanges. By further adjustment of the wedges, bring the coupling halves in reasonable alignment. Check alignment as directed in Section I—C 4 and 5 (page 3).
- (d) After the wedges have been adjusted, tighten foundation bolts evenly but only finger tight, maintaining the level of the bedplate. NOTE: Final tightening of foundation bolts is done after grout has set 48 hours. See Section I—C 2 (page 2).

5. Grouting Unit on Foundation:

- (a) Build wood dam around foundation as shown in Fig. 1 and wet top surface of concrete foundation thoroughly.
- (b) Pour grout in hole provided in the top of the bedplate. The grout should be thin enough to flow out under the bedplate but not so wet that the cement will separate from the sand and float to the surface. A mixture of one part Portland cement to three parts of sharp sand is suggested.
- (c) The grout should be puddled continuously as it is poured to expel the air and completely fill the space under the bedplate to the level of the grout hole in the top of the bedplate.
- (d) With a trowel, strike along the top of the wood dam to give a neat finished appearance at this point.

- (e) Allow grout to harden at least 48 hours.

I—C. ALIGNMENT—INITIAL.

Alignment of the pump and driver through the flexible coupling is of extreme importance for trouble-free mechanical operation.

If the driver was mounted at the factory, the unit was in alignment before it left our assembly department. However, in transit and subsequent handling, this factory alignment was probably destroyed; and, it is now necessary to re-establish the alignment. As directed in Section I—B 4 (c) (page 2), only approximate alignment was obtained by wedging under bedplate before grouting.

The following are suggested steps to establish the initial alignment of the pumping unit:

(NOTE THAT THIS IS AN INITIAL ALIGNMENT. THE FINAL ALIGNMENT IS DONE AFTER THE UNIT HAS BEEN RUN UNDER ACTUAL OPERATING CONDITIONS. THE FINAL ALIGNMENT PROCEDURE IS OUTLINED IN SECTION III-E AND MUST BE FOLLOWED.)

- 1. Be sure coupling halves are disconnected

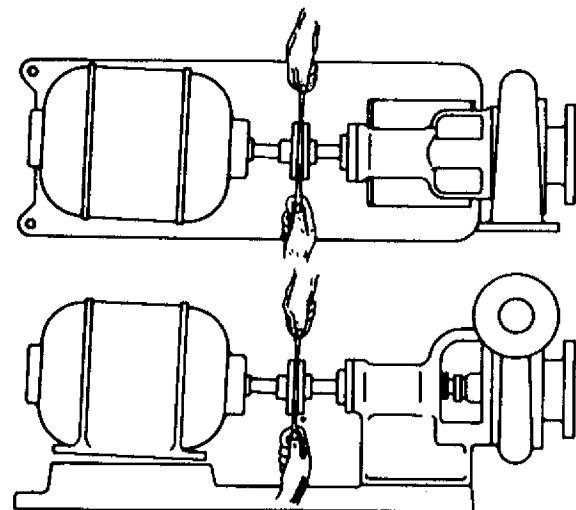

Fig. 3

70910

as previously instructed, except "Spider-Insert" type.

2. Tighten foundation bolts.
3. Tighten pump and driver hold-down bolts.
4. Check "gap" and angular misalignment — shaft axes concentric but not parallel.

(a) Couplings other than "Spider-Insert" Type.

The normal "gap" (distance between coupling halves) is $\frac{1}{8}$ ". Check angular misalignment by inserting a feeler or taper gauge at four points on the circumference of the coupling halves at 90° intervals. See Fig. 3. The unit will be in angular alignment when the measurements show the coupling faces are the same distance apart at all points. Adjustment for gap and for obtaining angular alignment is obtained by loosening the driver hold down bolts and shifting or shimming driver as required. Tighten driver hold down bolts after adjustments are made.

(b) "Spider-Insert" Type Coupling.

The normal "gap" (difference of the space between the coupling

halves and the thickness of the spider insert) is $\frac{1}{16}$ ". Check angular misalignment by using calipers at four points on the circumference of the outer ends of the coupling hubs at 90° intervals. See Fig. 4. The unit will be in angular alignment when the measurements show the ends of the coupling hubs to be the same distance apart at all points. Adjustments for obtaining the gap and angular alignment is obtained by loosening the driver hold down bolts and shifting or shimming driver as required. Tighten driver hold down bolts after adjustments are made.

5. Check parallel misalignment—shaft axes parallel but not concentric—by laying a straight edge across both coupling rims at top, bottom and both sides. See Fig. 5. This applies to both types of couplings.

The unit will be in horizontal parallel alignment when the straight edge rests evenly on both halves of the coupling at each side.

In order to secure vertical parallel alignment under actual operating conditions, the driver shaft must be set higher or lower than the pump

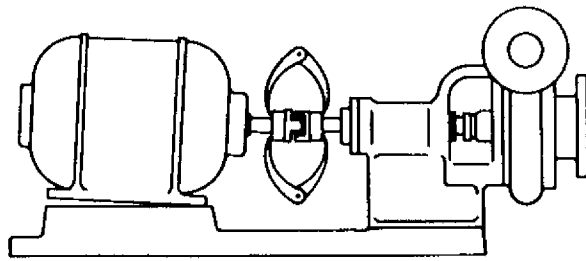
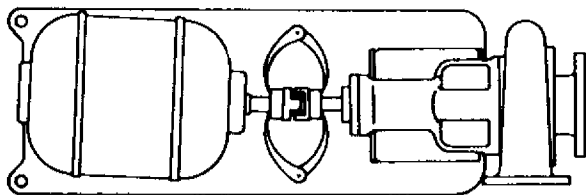

Fig. 4

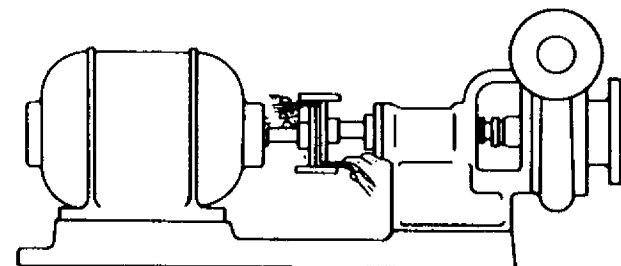
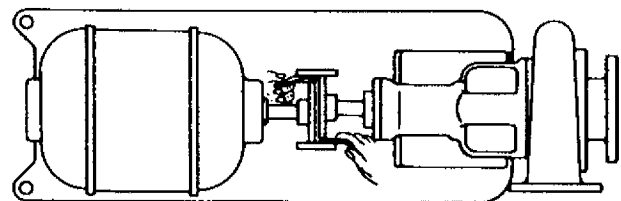

Fig. 5

shaft to compensate for vertical expansion. (When making final alignment while units are at operating temperatures, shafts must be at same height.) A suggested approximate cold setting for motor driven pumps is given below:

- (a) When pumping cold liquids, or when pump bearings are being cooled, set the motor shaft .006" below the pump shaft.
- (b) When pumping hot liquids (200-250°F), and cooling is not used, set the motor and pump shafts at the same height.

Measure the vertical difference of the shafts with straight edge and feelers.

Thin shim stock should be used under the driver feet to establish parallel alignment. (In some instances, shims may be required under the pump feet.)

6. Bear in mind always that alignment in one direction may alter the alignment in another. Check through each alignment procedure after making any alignment alteration.

I—D. PIPING—GENERAL.

1. All piping must be supported independently of the pump. The piping should always "line-up" naturally with the pump flanges. **NEVER DRAW THE PIPING INTO PLACE BY USE OF FORCE AT THE FLANGED SUCTION AND DISCHARGE CONNECTIONS OF THE PUMP!**
2. The piping, both suction and discharge, should be as short and direct as possible. Avoid all unnecessary elbows, bends and fittings, as they increase the friction losses in the piping. The size of pipe and fittings should be

carefully selected and of sufficient size to keep the friction losses as low as practical.

3. Piping must not be connected to the pump until the grout has thoroughly hardened and the foundation bolts as well as driver and pump hold down bolts have been tightened.
4. When handling liquids at elevated temperatures, arrangements must be made for expansion loops or expansion joints so that the linear expansion of the pipe will not cause the pumping unit to be drawn out of alignment.

I—E. PIPING—SUCTION.

1. General

Properly installed suction piping is of extreme importance for trouble-free centrifugal pump operation.

- (a) The suction pipe should be as large or larger than the pump suction.
- (b) Increases, if used, should be eccentric and preferably at or near the pump suction flange, sloping side down.
- (c) A centrifugal pump should *never* be throttled for capacity adjustment on the suction side.

2. Installation with Pump Above Source of Supply—Suction Lift:

- (a) Keep suction pipe free from air pockets.
 1. Piping should slope upwards from source of supply.
 2. No portion of piping should extend above the pump suction nozzle.
- (b) All joints must be air tight.
- (c) The suction pipe should always be submerged into the source of supply as shown in Fig. 6.
- (d) A foot valve should only be used if necessary for priming, or, if the

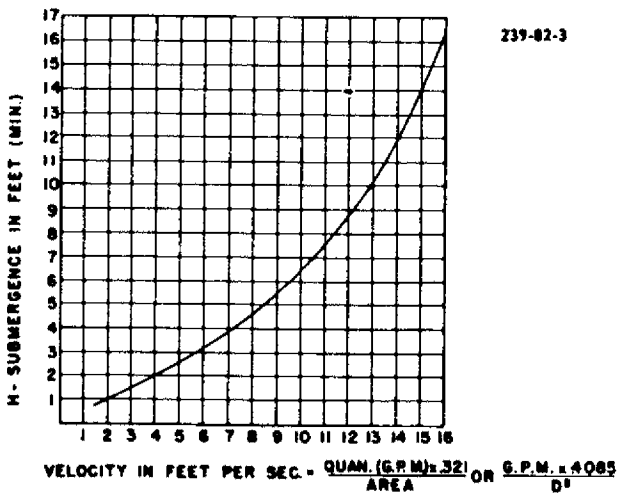
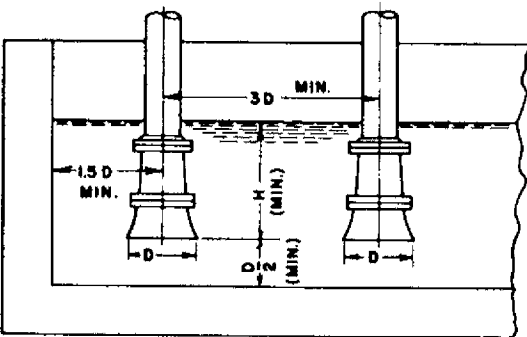
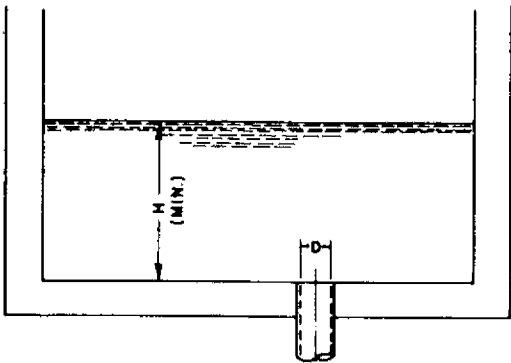
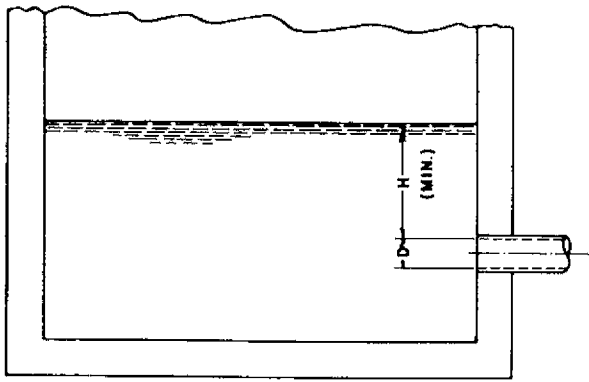

Fig. 6

pump is to be used on intermittent service and is required to hold its prime.

- (e) Suction strainers when used should have a net free area of at least three times the suction pipe area.

3. Installations with Pump Below Source of Supply—Suction Head or Flooded Suction:

- (a) A gate valve should be installed in the suction line to permit closing the line for pump inspection and maintenance.
- (b) The size of the entrance from the source of supply or minimum submergence over the entrance should be calculated from the data as shown in Fig. 6 for applicable condition to prevent air from being drawn into the pump.

I—F. PIPING—DISCHARGE.

1. A gate valve and a check valve should be installed in the discharge line. The check valve should be located between the gate valve and pump to permit inspection of the check valve. The gate valve is required for priming, regulation of flow capacity and for inspection and maintenance of the pump.
2. Increases, if used in discharge line, should be placed between the check valve and the pump.

I—G. CONNECTION OF PIPING.

Connect suction and discharge piping. Rotate the pump shaft by hand several complete revolutions to be sure that there is no binding and that all parts are free. Re-check alignment as described in Section I—C. If the connection of the piping causes unit to be out of alignment, correct piping to relieve strain on the pump.

I—H. CHECK ROTATION.

These pumps are built in right hand construction, i.e., clockwise rotation when viewed from driver end. The direction of rotation is marked on the pump casing. Make sure that driver rotates in the same direction. On electric motors, jog starting switch to be sure wiring is connected for correct rotation.

I—J. CONNECTION OF COUPLING.

Connect coupling, following instructions for the particular make of coupling furnished. This data is supplied separately, giving complete instructions for connection, lubrication, alignment and maintenance. "Spider-Insert" type couplings are pre-assembled.

SECTION II—PREPARATION FOR OPERATION

II—A. PUMP BEARINGS.

1. Grease Lubricated Bearings

Sufficient lubricant is inserted at the factory for 2000 hours operation.

2. Oil Lubricated Bearings

The pump bearings are flood oil lubricated, and are not lubricated at the factory.

A high quality turbine type oil, with rust and oxidation inhibitors, should be used. For the great majority of operating conditions, oil temperature will run between 50 and 180°F. In this range an oil of 300 SSU viscosity at 100°F. (approximately SAE 20) should be used. If oil temperature exceeds 180°F. for extended periods, use of cooling water in the bearing frame cooling jacket is recommended. For extreme conditions, refer to factory or a lubrication expert for a recommendation.

The constant level oiler (251) is in the box of fittings shipped with the pump. Oiler was adjusted to maintain proper oil level before leaving factory. If adjustment is lost, reset according to Fig. 7.

Install the constant level oiler (251) in the bearing frame.

Fill the oiler bottle with the proper grade of oil, and replace in the oiler. The frame is filled when an oil level remains in the bottle. Several fillings of the bottle may be required. Never fill the frame through

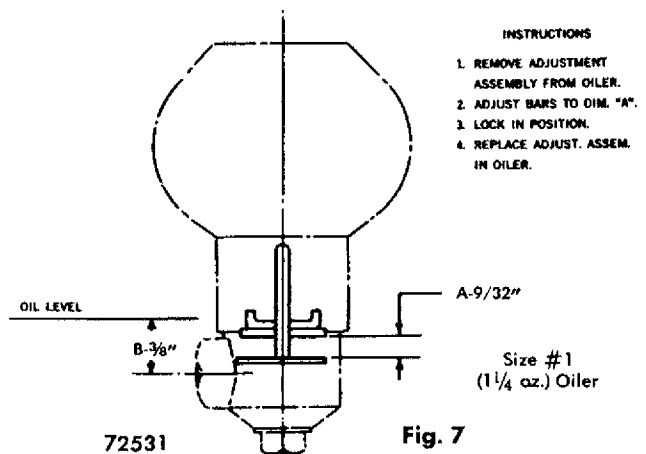

the frame breather (113-A) or through the oiler without use of the bottle.

II—B. DRIVER BEARINGS.

Check to be sure the driver bearings are properly lubricated.

II—C. STUFFING BOX.

These pumps are furnished with packing rings as standard. However, mechanical seals, either single or double, can be furnished on order.

1. Stuffing Box with Packing Rings:

The stuffing box packing is in the box of fittings accompanying the pump. The standard packing is die-formed to facilitate installation. The lantern ring may be one piece metal or split Teflon, depending upon pump construction.

When installing the packing and the

Teflon lantern ring (105), twist the rings sideways just enough to get them around the shaft. **DO NOT ATTEMPT TO PULL RINGS STRAIGHT OUT TO GET THEM OVER SHAFT.** (Fig. 8).

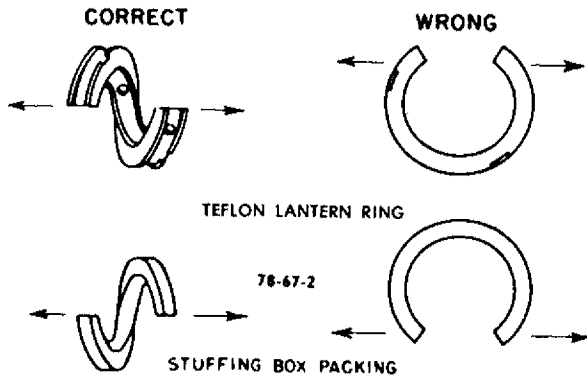

Fig. 8

If the lantern ring is metal, slide it (105) out and away from the stuffing box. (See Sectional Assembly, Section VI-D). Insert three rings of packing staggering the joints. The lantern ring (either metal or Teflon) should then be inserted in the stuffing box. When it is in its proper position, it will be directly opposite the sealing inlet connection.

After the lantern ring is in place, insert two more rings of packing, staggering the joints. One extra ring is furnished in each set of packing. The extra ring may be added as required.

Stainless steel and GA-20 pumps are supplied with quench style glands as standard. Insert length of $\frac{1}{8}$ " square asbestos packing into recess in each gland half, and trim off excess flush with face.

In all iron, all bronze, and bronze fitted constructions, the gland halves are held together by cupped washers which slide over the gland studs onto bosses on the gland halves. In stainless steel and GA-20 constructions, the gland halves are bolted together with the bolts and nuts supplied.

Install the gland halves on the shaft as described above. Place the two gland nuts on the gland studs and draw up evenly but not tightly.

2. Stuffing Box with Mechanical Seal:

When mechanical seals are furnished, they are installed and adjusted at the factory. The seal manufacturer's instructions and seal drawing are shipped with the pump. These should be read for any special instructions and filed for use in maintaining the pump.

If the pump has a single mechanical seal and is handling clear liquid, be sure circulating line from casing to stuffing box is connected. It is sometimes removed to prevent damage during shipment. This line insures circulation of liquid around seal. If pump is handling abrasive solids which might score the seal faces, the seal is usually flushed with clear compatible liquid from an outside source. The flush liquid keeps the solids in the pumpage away from the seal faces. A restricting bushing in the bottom of the stuffing box is used to control dilution of the pumpage. Flush liquid pressure should be great enough to insure steady flow into the stuffing box.

On double seal installations a clear compatible liquid from an outside source should be circulated through the stuffing box. Two $\frac{1}{4}$ " pipe tap openings provide entrance and exit of lubricating liquid to the seal chamber. The lubricating liquid pressure should be approximately 20 pounds greater than the suction pressure. Valves in the lines can be used to control flow and pressure. Sufficient flow should be allowed to prevent excessive heat generation in the stuffing box. If pumpage temperature is above 250°F. then this lubricating liquid should be cooled to prevent heat transfer along the shaft to the bearings. The circulating liquid provides lubrication to the seal faces and prevents the pumpage from entering between them. The circulating liquid pressure should be maintained as long as there is suction pressure.

II—D. CONNECTION OF SEALING LIQUID OR GREASE LUBRICATOR (PACKED BOX).

If the stuffing box is above atmospheric pressure, and the pumpage is clean,

normal gland leakage of 40-60 drops per minute is usually sufficient to lubricate and cool the packing, and sealing liquid is not required.

Sealing liquid or grease lubricator is required:

- (a) When abrasive particles in the pumpage could score the shaft.
- (b) Stuffing box pressure may be below atmospheric if pump is running with suction lift, or if suction source is under vacuum. Under these conditions, the packing will not be cooled and lubricated, and air will be drawn into the pump.

Sealing liquid may be supplied by recirculating pumpage to the lantern ring through a line from the casing to the $\frac{1}{4}$ " pipe tap seal connection in the stuffing box. The other seal connection is plugged. If the liquid is abrasive, an outside source of clean compatible liquid must be used at a pressure 20 to 40 psi above suction pressure.

A grease lubricator is supplied when the use of recirculating pumpage or outside sealing liquid is not desired. The grease should be compatible with, and insoluble in, the pumpage.

II—E. CONNECTION OF PIPING TO QUENCH GLAND.

A quench gland is standard on all packed pumps except iron or bronze, where it is supplied on special order. Use of a quench gland is required when the pumped liquid is:

1. Between 180°F and 250°F, if cooling water is not connected to the frame.
2. Between 250°F and 350°F, in addition to frame cooling.

Quenching is also suggested on applications where the pump is handling vola-

tile or toxic liquids in order to smother the gland leakage, which can then be piped away.

The quenching liquid must be from an outside source and should be piped with flexible pipe into the opening in the upper gland half and out the opening in the lower gland half. The openings in the gland halves are tapped for $\frac{1}{8}$ " pipe. A shut-off valve should be installed in the quenching line.

If pump has mechanical seals, quenching through special glands is recommended in conjunction with frame cooling for pumpage temperatures between 250°F and 350°F.

II—F. CONNECTION OF COOLING WATER PIPING.

The frame must be water cooled when the pumped liquid is:

1. Between 180°F and 250°F, if quench gland cooling is not used.
2. Between 250°F and 350°F, in addition to gland quenching.

The inlet piping must be at the bottom and the outlet at the top as shown in the Sectional Assembly Section VI-E (Page 17). The inlet should be on one side of the frame and the outlet on the other side. The remaining two holes must be plugged. The cooling water must be supplied from an outside source. A shut-off valve should be installed in the supply lines to regulate water flow.

II—G. CONNECTION OF DRAIN PIPING.

Connect the $\frac{1}{2}$ " pipe tap openings (from the drip pockets in the frame directly below the stuffing box) to drain. On pumps equipped with a drip basin (247) connect to the tapped opening on the end of the drip basin ($\frac{1}{4}$ " pipe tap) and out through the frame to drain.

SECTION III—STARTING PUMP

III—A. COOLING AND FLUSHING FLOWS.

Required cooling and flushing flows outlined in Section II must be started and regulated before the pump is started.

III—B. CHECK FOR FREE TURNING.

Turn shaft over by hand to be sure rotating element is free. If rotating element rubs or binds:

1. Check alignment.
2. Abnormal piping or other loads should be removed.
3. Check impeller clearance as directed in Section VI-C.

III—C. PRIMING.

The pump casing and suction pipe must always be full of liquid before the pump is started.

If pump is run dry, the rotating parts within the pump may seize to the stationary parts as they depend on the liquid being pumped for lubrication.

Start pump. After starting, open discharge valve if it was shut. If pump is allowed to run with a closed discharge valve for any length of time, it may overheat and seize. (See Section IV-B).

III—D. ADJUSTMENT OF STUFFING BOX GLAND.

With pump running at rated speed, stuffing box glands can be adjusted. Draw gland nuts up evenly and only one-sixth of a turn at a time, allowing sufficient time between adjustments for the packing to adjust itself and the effect on the leakage to be observed. If any sign of heating is evident,

shut off the pump and allow the boxes to cool. Several starts may be necessary before the boxes run cool. Do not back off the gland nuts on a hot box as this will usually result in liquid leaking between the outer edge of the packing and the stuffing box bore. It must be borne in mind that it takes newly-installed packing some time to "run in" and that during this period, frequent attention and careful adjustments are necessary. See IV-A for final adjustments of gland.

III—E. ALIGNMENT—FINAL.

Final alignment can only be accomplished after unit has been run under actual operating conditions for a sufficient length of time to bring the unit up to operating temperatures.

After this warm-up period has elapsed, stop the unit and immediately disconnect the coupling and check the alignment.

Follow the alignment procedure as outlined in I-C. As cautioned in I-C, changing alignment in one direction may alter the alignment in another. Check through each alignment procedure after making any alignment change.

Misalignment may be due to casing distortion from pipe strain. Correct piping to relieve strain on pump before checking alignment.

III—F. DOWELING.

Doweling is not required on these pumps. Patented lock washers are furnished which hold the pump and driver feet securely in place.

SECTION IV—OPERATION

IV—A. STUFFING BOX.

1. Stuffing Box with Packing Rings—less Quenching Gland and Grease Lubricator.

Periodically inspect stuffing box to see that there is sufficient leakage to lubricate the packing and maintain a cool box. Never draw up packing so that the stuffing box heats, as this will cause damage to both packing and shaft. Always draw up gland nuts evenly and only when pump is running.

After pump has been in operation for some time and the packing has been completely run in, at least 40 to 60 drops per minute of the liquid should be allowed to trickle from the stuffing box at all times for cooling and lubricating the packing and shaft sleeve.

2. Stuffing Box with Packing Rings—with Quenching Glands.

The same precautions as described above apply. However, the amount of leakage through the packing cannot be so readily ascertained, due to the quenching liquid. In most cases, the valve on the quenching liquid supply line can be shut off for a short period and the amount of leakage determined as in IV—A. In no instance should the gland be drawn up tight.

3. Stuffing Box with Packing Rings—with Grease Lubricator.

Operation is the same as directed in IV—A 1, with the addition that the

handle on the lubricator should be given a turn or two about every 100 hours of operation.

IV—B. OPERATING AT REDUCED CAPACITIES.

Do not operate a centrifugal pump at greatly reduced capacities or with discharge gate valve closed, because the energy required to drive the pump is converted into heat. If this condition exists over a long period, the temperature of the liquid in the pump may increase until the boiling point is reached. If this occurs, the rotating parts are exposed to vapor with no lubrication and they may score or even seize to the stationary parts; and furthermore, if running clearances have enlarged due to wear, seizure may not take place. Continued operation under these conditions may create an explosive hazard due to the confined vapor under high pressure and temperature.

To guard against possible damage, protective devices are available, such as:

1. Liquid temperature relay or thermostat which will shut-off the unit if the liquid temperature in the pump exceeds a predetermined maximum. This device guards against possible damage due to running the pump against a closed valve.

2. Constant open by-pass orifice between the pump discharge and any check or regulating valve in the discharge line. The liquid through the orifice is returned to the suction source. The amount of liquid by-passed is a function of input horsepower and the allowable temperature rise. This device also is insurance against damage due to running the pump against a closed discharge valve or very low flow conditions.

3. Bearing temperature relay which will shut the unit down if the bearing temperature exceeds a predetermined maximum.

4. Low suction pressure control which will shut off the unit should the suction pressure drop below a pre-established minimum.

A centrifugal pump should *never* be throttled for capacity adjustment on the suction side.

IV—C. OPERATING AT REDUCED HEAD.

On motor driven pumps, when discharge head or pressure is allowed to drop considerably below the rated point for any length of time, the motor should be watched for heating because the pump capacity increases rapidly with reduced head, as does horsepower consumption. If this condition is likely to persist, arrangements should be made either to manually or automatically

throttle the discharge valve to build up head to a safe point.

IV—D. OPERATING WITH SURGE CONDITIONS IN LINE.

If pump is installed with a quick closing valve in discharge line that closes when pump is running, dangerous pressure surges may be built up that can cause damage to the pump or line. In services of this kind, some cushioning arrangement must be provided to protect the pumping equipment.

IV—E. OPERATING UNDER FREEZING CONDITIONS.

When exposed to freezing conditions and pump is standing idle, liquid inside the pump and in the cooling jackets should be drained.

SECTION V—TROUBLE CHECK LIST

V—A. NO LIQUID DELIVERED.

1. Priming—casing and suction pipe not completely filled with liquid.
- *2. Speed too low.
3. Discharge head too high. Check total head (particularly friction loss).
4. Suction lift too high (suction pipe may be too small or long, causing excessive friction loss). Check with vacuum or compound gauge.
5. Impeller or suction pipe or opening completely plugged.
6. Wrong direction of rotation.
7. Air pocket in suction line.
8. Stuffing box packing worn—or liquid seal plugged—allowing leakage of air into pump casing.
9. Air leak in suction line.
10. Not enough suction head for hot or volatile liquids. Check carefully as this is a frequent cause of trouble on such service.

V—B. NOT ENOUGH LIQUID DELIVERED.

1. Priming—casing and suction pipe not completely filled with liquid.
- *2. Speed too low.
3. Discharge head higher than anticipated. Check total head (particularly friction loss).
4. Suction lift too high (suction pipe may be too small or long, causing excessive friction loss). Check with vacuum or compound gauge.
5. Impeller or suction pipe or opening partially plugged.

6. Wrong direction of rotation.
7. Air pocket in suction line.
8. Stuffing box packing worn—or liquid seal plugged—allowing leakage of air into pump casing.
9. Air leak in suction line.
10. Not enough suction head for hot or volatile liquids. Check carefully as this is a frequent cause of trouble on such service.
11. Foot valve too small.
12. Foot valve or suction pipe not immersed deeply enough.
13. Mechanical defects:
Impeller clearance too great.
Impeller damage.

V—C. NOT ENOUGH PRESSURE.

- *1. Speed too low.
2. Air or gases in liquid.
3. Impeller diameter may be too small.
4. Mechanical defects:
Impeller clearance too great.
Impeller damaged.
5. Wrong direction of rotation.
6. Be sure pressure gauge is in correct place on discharge nozzle or discharge pipe.

V—D. PUMP WORKS AWHILE AND THEN QUILTS.

1. Leaky suction line.
2. Stuffing box packing worn—or liquid seal plugged—allowing leakage of air into pump casing.

3. Air pocket in suction line.
4. Not enough suction head for hot or volatile liquids. Check carefully as this is a frequent cause of trouble on such service.
5. Air or gases in liquid.
6. Suction lift too high (suction pipe may be too small or long, causing excessive friction loss.) Check with vacuum or compound gauge.
7. Impeller plugged.

V—E. PUMP TAKES TOO MUCH POWER.

1. Speed too high.
2. Head lower than rating, pumps too much liquid.
3. Liquid heavier than anticipated. Check viscosity and specific gravity.
4. Mechanical defects:
 - Shaft bent.
 - Rotating element binds.
 - Stuffing box too tight.
 - Pump and driving unit misaligned.
5. Wrong direction of rotation.

V—F. PUMP LEAKS EXCESSIVELY AT STUFFING BOX.

1. Packing is worn or not properly lubricated.
2. Packing is incorrectly inserted or not properly run in.
3. Packing is not right kind for liquid handled.
4. Shaft scored.

V—G. PUMP IS NOISY.

1. Hydraulic noise — cavitation, suction lift too high. Check with vacuum or compound gauge.
2. Mechanical defects:
 - Shaft bent.
 - Rotating parts bind, are loose or broken.
 - Bearings worn out.
 - Pump and driving unit misaligned.

*When connected to electric motors, check whether motor wiring is correct and receives full voltage. When connected to steam turbines, make sure that turbine receives full steam pressure.

SECTION VI—CARE AND MAINTENANCE

VI—A. LUBRICATION

1. Grease Lubricated Bearings

As specified in Section II—A, bearings are lubricated at the factory for 2000 hours or three months service. **DO NOT GREASE AT TOO FREQUENT INTERVALS.** It is suggested that additional or replacement lubricant be added only after 2000 hours operation or at three months intervals.

Insert grease through the “Alemite” fittings (193) into bearing housing until grease appears through relief fitting (113). **DO NOT ADD ADDITIONAL LUBRICANT AFTER GREASE APPEARS THROUGH RELIEF FITTING.**

The lubricant should be renewed in the housings at least once annually. This should be done when annual overhaul is made.

The ball bearing grease should be of a sodium or lithium base, NGLI #2 consistency. **DO NOT USE GRAPHITE.**

2. Oil Lubricated Bearings

- (a) Keep oiler bottle filled with correct grade of oil. (See Section II-A). Oiler will maintain constant oil level in bearing frame.
- (b) Under normal operating conditions, a good grade of oil will be suitable for 6 months to one year between changes, as long as it is free

from contaminants. A small sample of oil should be drained from the bearing frame periodically. Any cloudiness, turbidity, discoloration or presence of solids is evidence of contamination, and the oil should be changed immediately.

- (c) If oiler adjustment is lost or disturbed, reset as directed in Section II-A.

VI—B. REPACKING STUFFING BOX.

1. Loosen gland nuts and slide gland along shaft out of stuffing box. Remove gland halves from pump.
2. Remove the outer rings of packing with the aid of a packing hook.
3. Remove lantern ring (105) by inserting a wire hook in the slots in the outer edge of the ring and pulling ring from box.
4. Remove the three inner rings of packing with the aid of a packing hook.
5. Remove all foreign matter from stuffing box.
6. Install stuffing box packing as described in Section II—C.

VI—C. ADJUSTING IMPELLER CLEARANCE.

1. Stop pump. Loosen set screw in deflector (123).
2. Loosen bolts (370 D). See Sectional Assembly VI—D.

3. Tighten (turn clockwise) the three bolts (370 C) evenly while rotating the shaft slowly until the impeller (101) just starts to rub the suction cover (182).
4. Now loosen (turn counter-clockwise) the three bolts (370 C) a flat and a half of a turn, or until a 0.015" feeler can just be inserted between the heads of the bolts and the bearing housing (111).
5. Be sure jam nuts on bolts (370 D) are loose. Tighten each bolt (370 D) a

flat at a time until bearing housing is tight against heads of bolts (370 C).

6. Check to be sure all bolts (370 C and 370 D) are tight.
7. Tighten jam nut on bolts (370 D).
8. This will result in the required clearance of .015" between the impeller and the suction cover.
9. Adjust clearance between the deflector and the end of the frame to about 1/32" and tighten set screw.

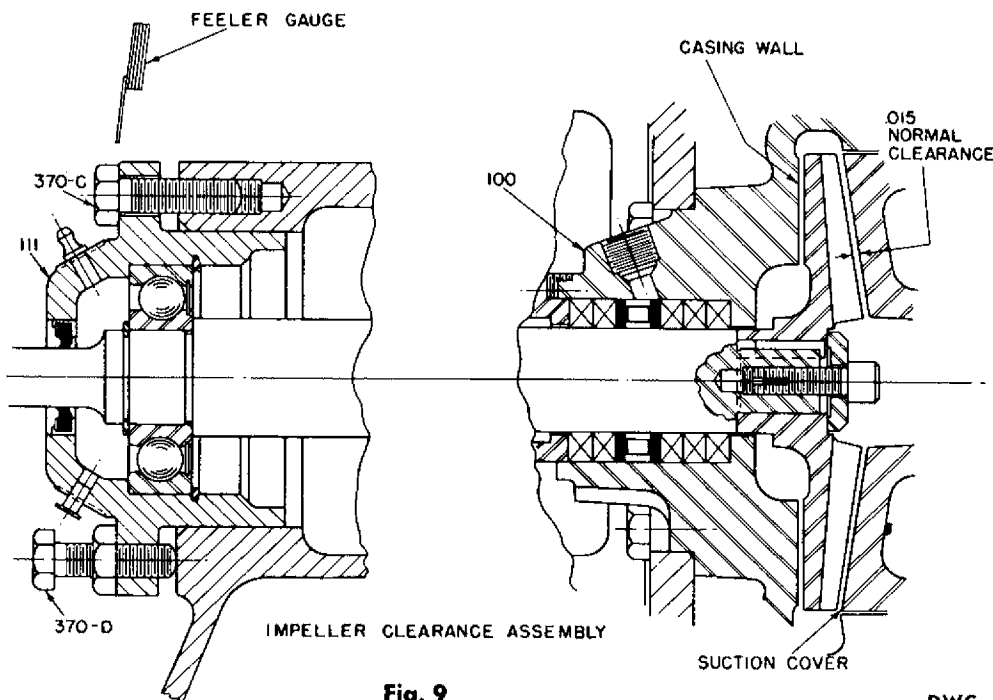

Fig. 9

DWG. 83249

VI—E. REPLACING IMPELLER.

1. Shut off all valves controlling the flow of liquid to or from the pump.
2. Drain the liquid from the pump.
3. Disconnect coupling.
4. Loosen bolts (370 C and 370 D).
5. Disconnect suction piping and remove a section to allow sufficient working space and disconnect discharge piping.

6. Remove suction cover (182) See Fig. 11.
7. Remove the socket head impeller screw (198) and impeller washer (199).
8. Remove bolts (370-B) which hold casing (100) to frame (228 or 228-A).
9. Bolt puller bar to casing with two casing bolts (370-A), as shown (Fig. 10). As jack screw is tightened, casing will bear on back of impeller (101) and pull impeller from shaft

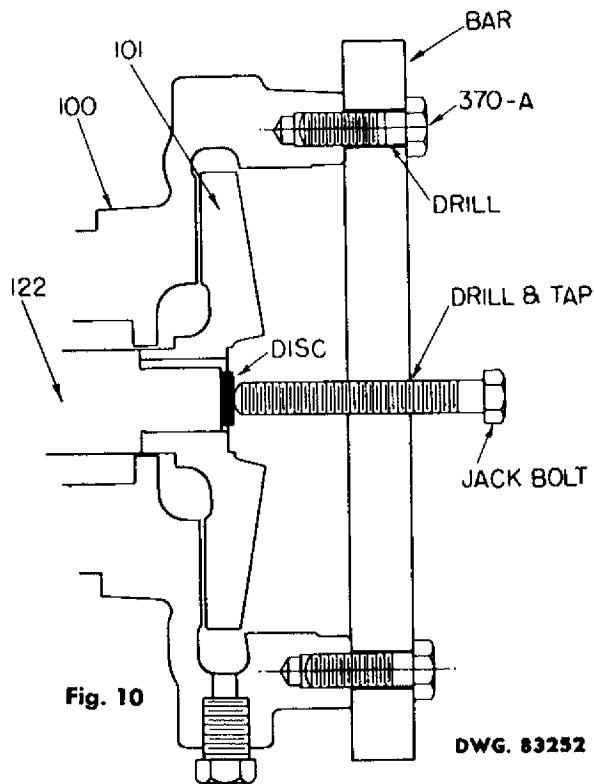

(122). Use a metal disc or washer to protect end of shaft.

10. Check the condition of the impeller for excessive erosion, especially on the vane faces and ejector vanes on the back side of impeller.
11. Substitute worn parts with new ones where needed.
12. Bolt casing to frame with bolts (370 B).
13. Be sure impeller key is properly located in shaft.
14. Slide impeller on shaft as far as possible.
15. The impeller screw and washer may be used to push the impeller on the remaining distance. Do not tighten impeller screw more than 120 inch-pounds of torque.
16. Replace suction cover gasket (351) and suction cover (182).
17. Adjust impeller as directed in Section VI—C.

VI—F. REPLACING SHAFT OR BEARINGS.

1. Shut off and disconnect all piping.
2. Drain liquid from pump.
3. Disconnect coupling.
4. Remove pump hold-down bolts and remove pump from bedplate.
5. Remove impeller as instructed in Section VI—E and impeller key (178).
6. Remove gland assembly as instructed in Section VI—B .
7. Loosen set screw in deflector (123)
8. Note the distance from the end of the shaft to the coupling face of the pump half coupling so that coupling half can be correctly positioned when reassembled. Pull the coupling from pump shaft with a suitable puller.
9. Remove coupling key.
10. Remove machine bolts 370 C) from bearing housing (111).
11. Shaft and bearings can now be pulled through coupling end of frame.
12. To remove ball bearing-coupling end (112) proceed as follows:
Using suitable pliers, remove the retaining ring-bearing housing (361A) which is seated in the housing and shoulders against the outer race of the bearing. The housing can now be slipped over the bearings. Remove the retaining ring-shaft (361) which is seated in the shaft and retains the inner race of the bearing. With the use of a suitable bearing puller, which engages the bearing on the inner race only, remove coupling end bearing (112).
13. To remove ball bearing-inboard end (168) slide a suitable pipe or sleeve over shaft to bearing, being sure that the pipe rests only on inner race. By evenly tapping the free end of the pipe, the bearing will be forced off without damaging it or the shaft.

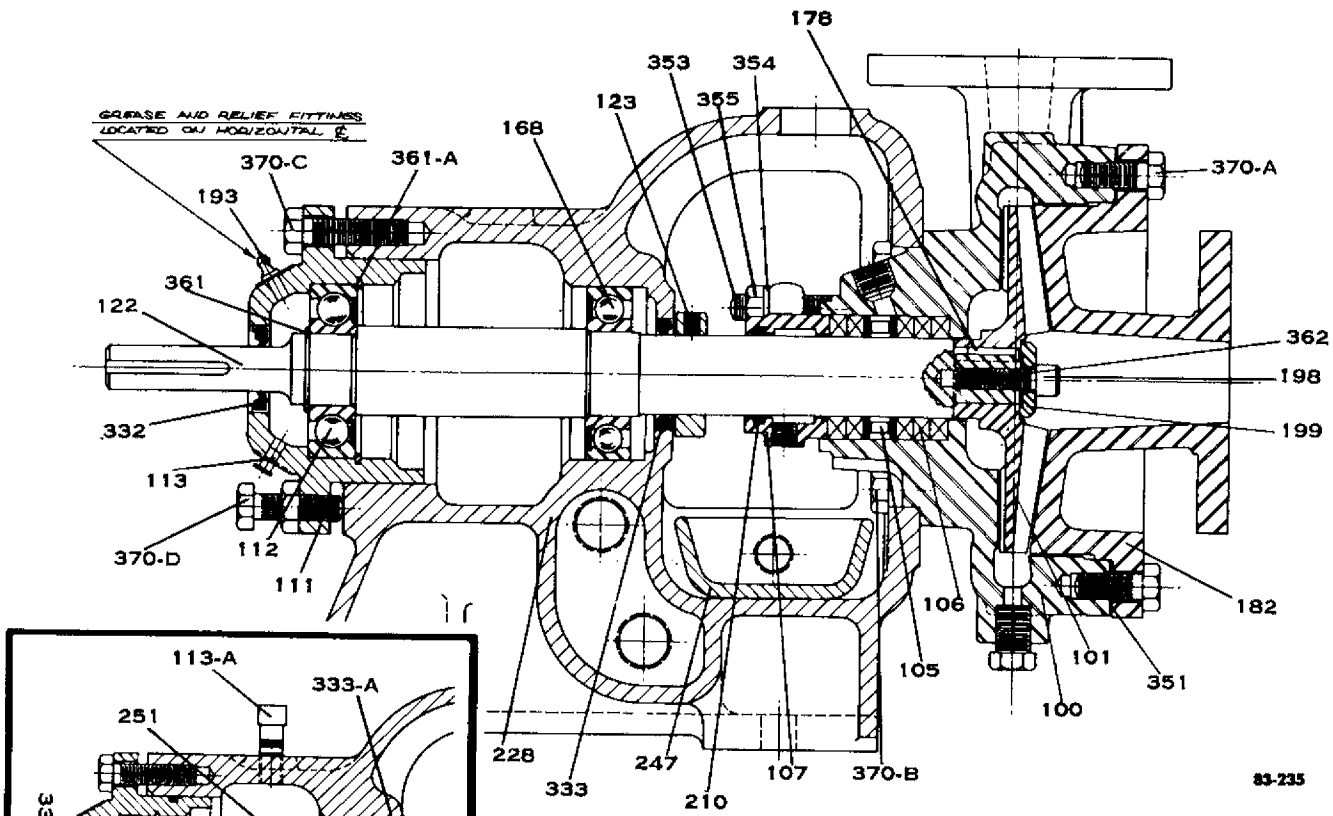

▲ SECTIONAL showing grease lubrication
 ▲ DETAIL showing oil lubrication

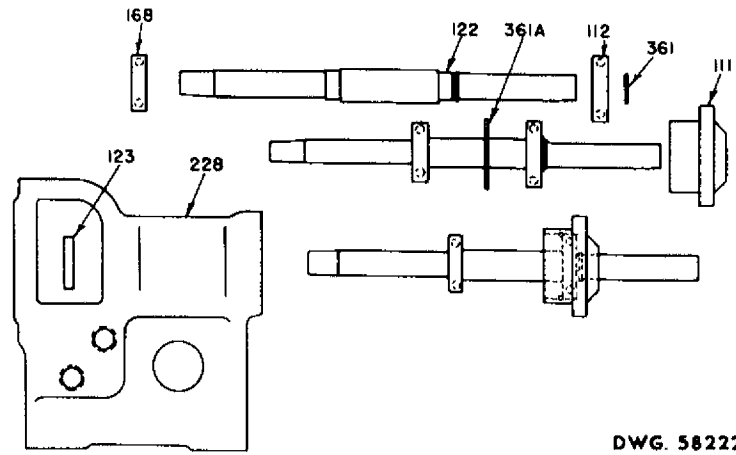
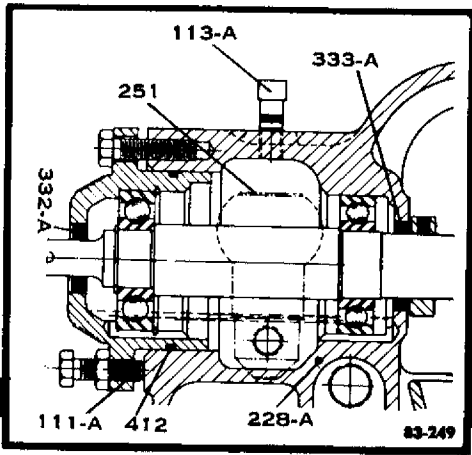

EXPLODED ASSEMBLY ▲
 Fig. 11

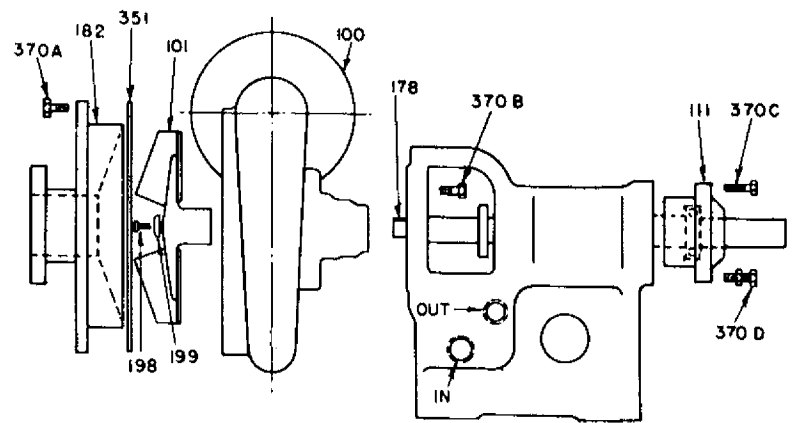



INTERCHANGEABILITY CHART

ITEM NO.	NO. REQ'D.	PART NAME	MATERIAL OF CONSTRUCTION					INTERCHANGEABILITY		
			BRZ FTD	ALL IRON	ALL BRZ	316 SS	GA-20	1x1-5	1x1 1/2-6	1 1/2x3-6
100	1	CASING	1000		1103	316	GA-20	1x1-5	1x1 1/2-6	1 1/2x3-6
101	1	IMPELLER	1103	1000	1103	316	GA-20			
105	1	LANTERN RING	1102	1000	1102	TEFLON		T	T	T
106	1	STUFFING BOX PACKING	★			□				
107	1	STUFFING BOX SPLIT GLAND	1106	1000	1106	316	GA-20	T	T	T
111*	1	BEARING HOUSING (OUTBOARD) Grease Lubricated			1000			T	T	T
111-A*	1	BEARING HOUSING (OUTBOARD) Oil Lubricated			1000			T	T	T
112*	1	BALL BEARING—COUPLING END			STEEL			T	T	T
113*	2	GREASE RELIEF FITTING			STEEL			T	T	T
113-A*	1	OIL BREATHER FITTING			STEEL			T	T	T
122	1	SHAFT	SAE 4150 ▲		316		C-20	T	T	T
123	1	DEFLECTOR			1000			T	T	T
168*	1	BALL BEARING—INBOARD			STEEL			T	T	T
178	1	IMPELLER KEY			316		C-20	T	T	T
182	1	SUCTION COVER	1000		1103	316	GA-20	1x1-5	1x1 1/2-6	1 1/2x3-6
193*	2	GREASE FITTING			STEEL			T	T	T
198	1	IMPELLER SCREW			316		C-20	T	T	T
199	1	IMPELLER WASHER			316		C-20	T	T	T
210	1	GLAND PACKING			NONE		□	T	T	T
228*	1	FRAME (GREASE LUBRICATED)			1000			T	T	T
228-A*	1	FRAME (OIL LUBRICATED)			1000			T	T	T
247*	1	DRIP BASIN	NONE		1103		316	T	T	T
251*	1	CONSTANT LEVEL OILER			STEEL AND GLASS			T	T	T
332*	1	GREASE OR OIL SEAL (COUPLING END)			SYNTHETIC RUBBER			T	T	T
333*	1	GREASE OR OIL SEAL (INBOARD END)			SYNTHETIC RUBBER			T	T	T
351	1	SUCTION COVER GASKET			1/64" ASBESTOS			5	6	6
353	2	GLAND STUD			C-20			T	T	T
354	2	GLAND HOLDING WASHER	AISI 416				NOT REQ'D.	T	T	T
355	2	GLAND STUD NUT			AISI 304			T	T	T
351*	1	RETAINING RING—SHAFT			STEEL			T	T	T
361-A*	1	RETAINING RING—BEARING HOUSING			STEEL			T	T	T
362	1	IMPELLER SCREW INSERT			RED FIBRE			T	T	T
370-A	A-B	HHMB (CASING TO SUCTION COVER)	STEEL			AISI 304		T	T	T
370-B	4	HHMB (CASING TO FRAME)	STEEL			AISI 304		T	T	T
370-C*	3	HHTB BEARING HOUSING			STEEL			T	T	T
370-D*	3	HHTB (ADJUSTING SCREW)			STEEL			T	T	T
408-A*	1	OIL DRAIN PLUG (NOT ILLUS.)			STEEL			T	T	T
412*	1	"O"—RING			BUNA RUBBER			T	T	T

★ Die formed, white metal, graphite, long fibre asbestos.

▲ Flame hardened to approx. 500 brinell through stuffing box.

□ Die formed, Mica, impregnated, long fibre blue African asbestos.

* Interchangeable with Model 3706.

TYPICAL MATERIAL ANALYSIS

No.	Cu %	Sn %	Pb %	Zn %	Ni %	P %
1102	84-86	4-6	4-6	4-6	—	—
1103	87	6	4.5	1.75	0.75	—
1106	84	8	8	—	—	0.10-0.15

1000 CAST IRON CORRESPONDING TO ASTM A 278-59T CLASS 25 AND ASTM A 48-56 CLASS 25

316 DESIGNATES AISI 316 ((WROUGHT), ACI CF-8M AND ASTM A 296-60 GRADE CF-8M (CAST)

GA-20 DESIGNATES COMPOSITION SAME AS ACI CN 7M CU (CAST), SIMILAR TO CARPENTER 20 (WROUGHT)

C-20 DESIGNATES CARPENTER 20



CONSTRUCTION DETAILS

		1x1-5	1x1 1/2-6	1 1/2x3-6
PUMP	WEIGHT—BRONZE FITTED BARE PUMP, LBS.	60	65	75
	CASING THICKNESS—VOLUTE	5/16	5/16	5/16
	CASING THICKNESS—SIDE WALLS	5/16	5/16	5/16
	MAXIMUM DIAMETER SOLIDS	3/16	9/32	7/16
STUFFING BOX	STUFFING BOX BORE		1 3/4	
	STUFFING BOX DEPTH		1-13/16	
	STUFFING BOX PACKING—SIZE		5/16x3/4	
	STUFFING BOX—NO. OF PACKING RINGS		5	
	WIDTH OF LANTERN RING		7/16	
SHAFT	SHAFT DIAMETER AT IMPELLER		1 1/16	
	SHAFT DIAMETER IN STUFFING BOX		1 1/8	
	SHAFT DIAMETER AT COUPLING END		5/8	
	SHAFT DIAMETER BETWEEN BEARINGS		1 1/4	
BEARINGS	BALL BEARING—COUPLING END	MRC 305-SF †	OR EQUAL	
	BALL BEARING—INBOARD	MRC 206-SF †		
	DISTANCE BETWEEN CENTER LINE OF BEARINGS			3 7/8
GENERAL	MAXIMUM TOTAL WORKING PRESSURE	150 PSI		
	MAXIMUM TEST PRESSURE	225 PSI		
	MAXIMUM LIQUID TEMPERATURE (WITHOUT COOLING)	180° F		
	MAXIMUM LIQUID TEMPERATURE (W/QUENCHING GLAND OR WATER COOLED FRAME)	250° F		
	MAXIMUM LIQUID TEMPERATURE (W/QUENCHING GLAND & WATER COOLED FRAME)	350° F		

†Shielded one side. Oil lubricated bearings unshielded.

14. Inspect shaft and bearings. If shaft is bent it must be straightened. Check especially for wear or corrosion that portion of the shaft in the stuffing box. If necessary, replace or metalize the shaft. Bearings should spin smoothly and evenly. If bearings are not in first class condition, they should be replaced. If bearings are to be reused they should be carefully cleaned with kerosene. The bearing housing (111) and the frame (228) should also be flushed and cleaned.
15. It is important that all parts are free from dirt and grit while being assembled. Note that grease lubricated bearings are shielded on one side to retain the grease and they must be installed properly as shown in Sectional Assembly Section VI—D (Shields on the two bearings facing each other).
16. To replace the ball bearing-inboard end (168), oil shaft at bearing seat and slide bearing over the shaft as far as possible by hand. Place the pipe or sleeve used to remove bearing over the shaft and against the bearing, being sure that it rests only on the inner race. Tap evenly until the bearing is seated firmly against the shaft shoulder. Care should be taken not to mar the shaft, especially where it contacts the grease seal (333) or in the stuffing box area.
17. To replace ball bearing-coupling end (112) oil shaft at bearing seat and slide bearing over the shaft as far as possible by hand. Using a suitable pipe or sleeve which rests only on the inner race of the bearing, tap evenly on the free end of the pipe until the bearing is seated firmly against the shaft shoulder.
18. Insert the retaining ring (361) in the shaft groove. Note that the flat side of the ring is against the bearing.
19. Carefully slide the bearing housing (111) over the shaft and bearing as far as possible. Insert the retaining ring (361 A) in the groove in the bearing housing. All retaining ring grooves must be clean and the retaining rings must be properly seated. Note that the flat side of the ring is against the bearing and the tapered side away from the bearing.
20. Carefully insert shaft, bearings and bearing housing in frame. Remember to place the deflector (123) and lantern ring (if metal) (105) on shaft as it protrudes through grease seal (133).
21. Replace impeller and suction cover, and adjust impeller as instructed in Section VI—E.
22. Replace pump half coupling on shaft. Insert the coupling key in shaft. Put oil or white lead on the shaft and in the coupling bore. Place the complete pump half coupling in position over the stud and align the key with the keyway.
Locate the coupling half in the same position on the shaft as it was before dismantling.
23. Place pump on bedplate, insert hold-down bolts and align unit as directed in Section I—C.
24. Insert grease through "Alemite" fittings as directed in Section VI—A.
25. Connect coupling.
26. Connect piping as directed in Section I—G.
27. Follow directions in Section III for initial operating conditions and for starting.

VI—G. REPLACING CASING.

1. Shut off and disconnect all piping from pump.
2. Drain liquid from pump.
3. Remove suction cover and impeller as instructed in Section VI—E.
4. Remove gland assembly as instructed in Section VI—B.
5. Remove machine bolts (370B). Pull casing from frame.
6. Remove stuffing box packing and lantern ring. If lantern ring is metal, replace it on shaft.
7. Place new casing on frame and fasten with machine bolts (370B).
8. Replace impeller and cover as instructed in Section VI—E.
9. Adjust impeller clearance as instructed in Section VI—C .
10. Repack stuffing box as directed in Section VI—B.
11. Connect piping as directed in Section I—G.
12. Follow directions in Section III (page 9) for initial operating conditions and for starting pump.

VI—H. SPARE PARTS.

To insure against possible long and costly "down-time" periods, especially on critical services it is advisable to have spare parts on hand.

1. One set of group parts should be maintained for every one to three pumps of that particular group size in operation. Pumps of the same group size have all parts interchangeable except casing, suction cover and im-

PELLER—see interchangeability chart Section VI—D. The following is a list of recommended group parts:

- (a) Stuffing box packing (106)—1 set required.
 - (b) Stuffing box gland complete (107)—one required
 - (c) Ball bearing-coupling end (112)—one required.
 - (d) Ball bearing-inboard (168)—one required.
 - (e.) Shaft (122)—one required.
 - (f) Impeller key (178)—one required.
 - (g) Impeller screw (198)—one required.
 - (h) Impeller washer (199)—one required.
2. For each size pump it is suggested that one impeller (101) be maintained.

VI—I. INSTRUCTIONS FOR ORDERING SPARE PARTS

Repair orders will be handled with the minimum of delay if the following directions are followed:

1. Give the Model No., Size of the pump and Serial Number. This data can all be obtained from the nameplate.
2. Write plainly the names, part numbers and material of the parts required. These names and numbers should agree with those on the sectional assembly (Section VI—D).
3. Give the number of parts required.
4. Give complete shipping instructions.

A pump is only as good as its parts.

The Goulds pump featured in this instruction manual is made up of many different parts. All are engineered and precision manufactured to make the pump perform as intended. Therefore it's *most important* to make sure that you use only genuine Goulds replacement parts.

To assure that you can make no better choice than Goulds, we offer the best pump parts program in the industry. We call it "pump parts like never before" and very simply means unsurpassed *availability, service, quality and value.*

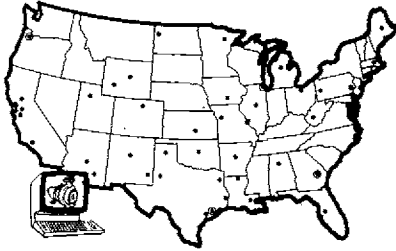

Availability A nationwide, computer-controlled distribution network backed by factory programs designed to get you the part you need — when you need it.

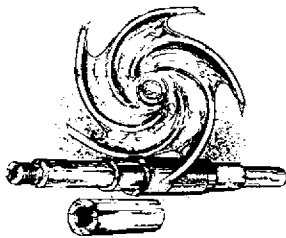

Quality Goulds is committed to providing the highest *original* quality and sometimes *better* if design or material improvements have been made.

Service Our Certified Original Parts specialists are dedicated to serving your parts needs by:

- Helping minimize parts inventories
- Delivering parts
- Providing maintenance consultation service

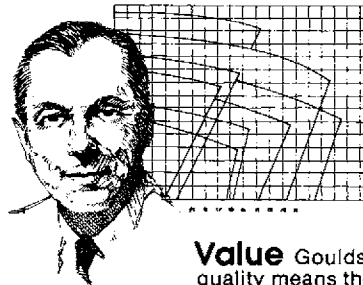

Value Goulds high standards of quality means the part will fit right and meet original standards of performance.

GOULD'S PUMPS
GP PARTS
THE REAL ONES



ITT

Form I3199