

# ZUU-50

## Dimensional drawing

# SULZER

COPYRIGHT © AHLSTROM PUMPS CORP.

030930 / Replaces 981201 / en / P02129

Dimensions in mm (inch)  
CLOCKWISE

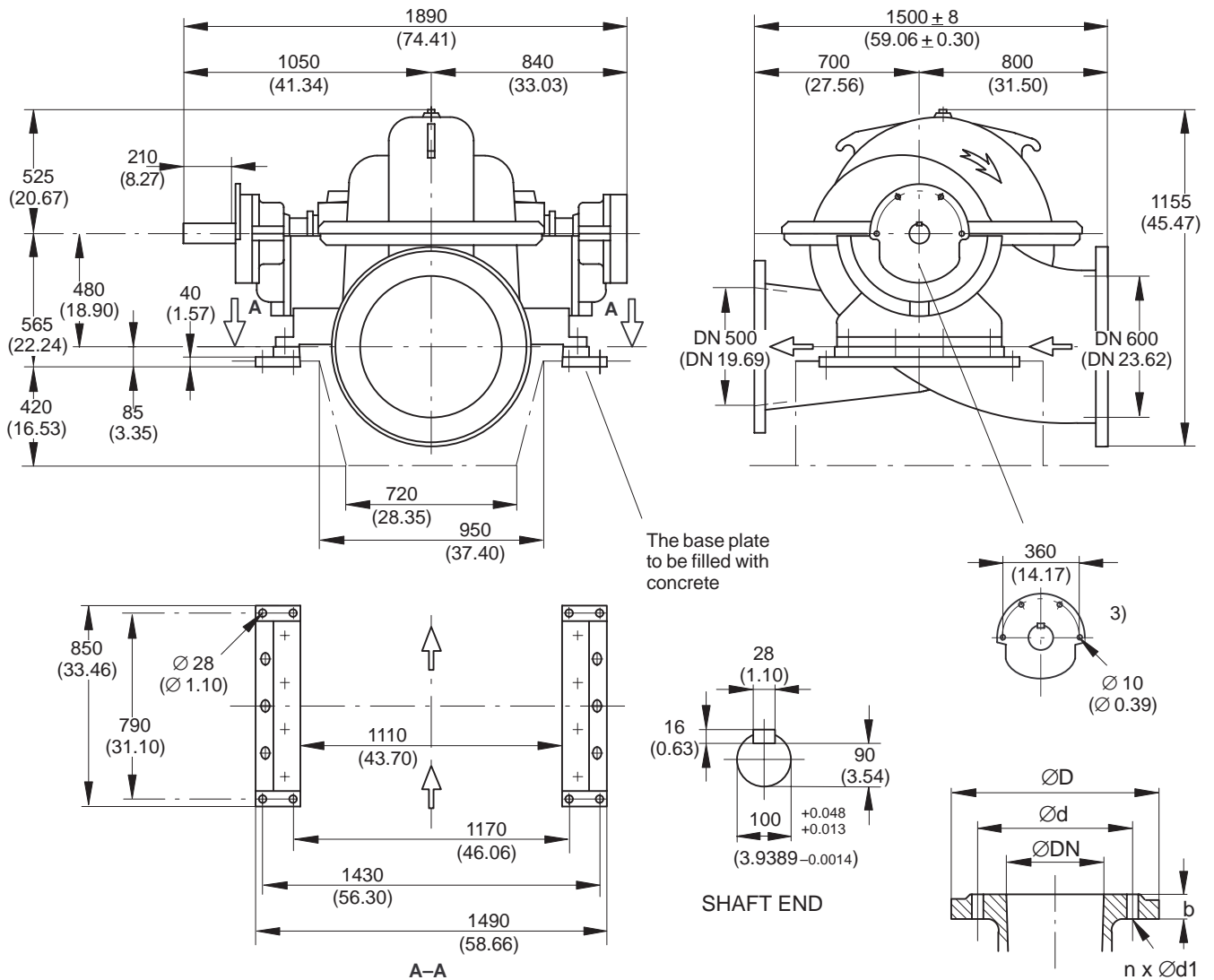
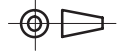

		Drilling of flanges																		
		ISO 7005-1 PN 10			ISO 7005-1 PN 16			JIS B 2238 10K JIS B 2239 10K			JIS B 2238 16K JIS B 2239 16K			ANSI B 16.1 class 125			ASME B 16.5 class 150			
DN	D	b	d	d1	n	d	d1	n	d	d1	n	d	d1	n	d	d1	n	d	d1	n
500	730	47	620	26	20	650	32,5	20	620	27	20	660	33	20	(25.00)	(1.25)	20	(25.00)	(1.25)	20
(19.69)	(28.74)	(1.85)	(24.41)	(1.02)		(25.59)	(1.30)		(24.41)	(1.06)		(25.98)	(1.30)							
600	845	51	725	29,5	20	770	35,5	20	730	33	24	770	39	24	(29.50)	(1.38)	20	(29.50)	(1.38)	20
(23.62)	(33.27)	(2.01)	(28.54)	(1.16)		(30.31)	(1.40)		(28.74)	(1.30)		(30.31)	(1.54)							

Weight <sup>1)</sup>		Mass inertia moment <sup>2)</sup>	
m = 2700 kg	(m = 5955 lb)	J = 4,6 kgm <sup>2</sup>	(WR <sup>2</sup> = 109.2 lbf <sup>2</sup> )

The right to any alternation in dimensions without an advance notice is reserved.

1) Mass is without coupling and motor.

2) Mass inertia moment J= kgm<sup>2</sup>

3) Holes for fastening the guard